

ISO 9001



AUTOMATIC VALVE



World Class Pneumatic Solutions

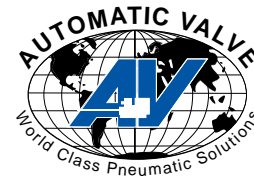

Automatic Valve Corp

**Novi, Michigan
USA**



Automatic Valve is here to serve your pneumatic actuation needs.

Since 1945, Automatic Valve's exclusive focus has been fluid power. Engineering and Quality are our foundations. Our systems are registered to ISO 9001:2008, certified to ANSI N45.2 and ASME . Our engineers are experienced, knowledgeable, and customer focused.

With a library of thousands of working applications, we can quickly provide you with a solution to your specialized pneumatic needs. Our network of full service distribution is available to help with on-site support, rapid deliveries and total package solutions.

Whether you are looking for a single air valve, a manifold with complicated pneumatic circuitry, or something individually dedicated to your specifications, we can help with a world class pneumatic application.

T. 248.474.6700

F. 248.474.6732

E. avc@automaticvalve.com

I. www.automaticvalve.com

World Class Pneumatic Solutions

L20 4 Way



L20 3 Way



L45



D20



I15 (ISO 1)

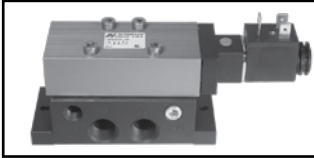

A06 (SAE 250)

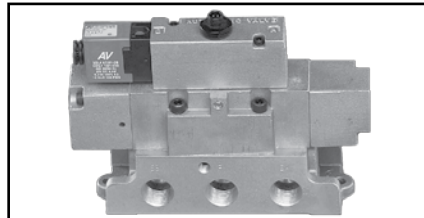

K02

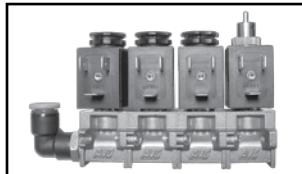

P06



Accessories

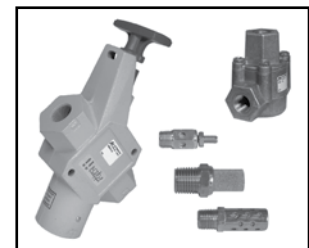

Product Index

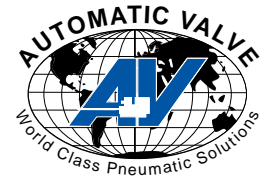

Section	Series	Description	Port Size	Function	Flow Cv		Valve Mounting	Actuation				Section
					5/2	5/3		Direct Solenoid	Pilot Solenoid	Air Pilot	Manual	
					3/2							
A	L07	Compact	1/8, 1/4	5/2* 5/3	0.7	0.5	Inline Manifold		✓	✓	✓	A
	L20		1/4, 3/8		1.8	1.4			✓	✓	✓	
	L65		3/4, 1		9.0, 9.5	7.0, 7.4			✓	✓	✓	
B	L20	3 Way Compact	1/4, 3/8	3/2	1.8		Inline Manifold		✓	✓	✓	B
	L21				1.8				✓			
	L45		1/2		4.0				✓	✓	✓	
C	L05	Top Mount	1/8	5/2* 5/3	0.4	-	Inline Manifold		✓	✓	✓	C
	L07		1/8, 1/4		0.7	0.5			✓	✓	✓	
	L21		1/4		1.8	1.4			✓	✓	✓	
	L45		1/2		4.8	3.7			✓	✓	✓	
D	D06	NAMUR Actuator	1/4	3/2	0.06		Direct Actuator		✓			D
	D20		1/4	3/2 5/2, 5/3	1.8	1.4			✓	✓		
E	I15	ISO	1/4, 3/8	5/2* 5/3	1.5	1.2	Sub-Base Manifold		✓	✓	✓	E
	I20		3/8, 1/2		2.0	1.6			✓	✓	✓	
	I45		1/2, 3/4		4.5	3.5			✓	✓	✓	
F	A04	SAE	1/4, 3/8	5/2* 5/3	2.4	1.9	Sub-Base Manifold		✓	✓	✓	F
	A06		1/2, 3/4, 1		8.6	6.7			✓	✓	✓	
	A20		1 1/4, 1 1/2		22.7	17.7			✓	✓		
G	K02	Direct Operated	1/8, 1/4	2/2 3/2	0.1		Sub-Base Manifold	✓				G
	K03		1/8, 1/4		0.2		Inline	✓				
	K08		1/4		0.8		Inline				✓	
H	P06	Pilot Inline Poppet	1/4, 3/8, 1/2	2/2 3/2	3.2, 3.9, 5.5		Inline		✓	✓		H
	P14		1/2, 3/4, 1		8.3, 11.3, 13.8				✓	✓		
	P36		1, 1 1/4, 1 1/2		29.5, 31.8, 33.8				✓	✓		
I	Accessories: Flow Controls, Check Valves, Lockout Valves, Mufflers, Pneumatic Accessories										I	
J	Precautions, Engineering, Maintenance, and Glossary										J	

* Spool valves can be plugged for 2way or 3way function.

AV AUTOMATIC VALVE

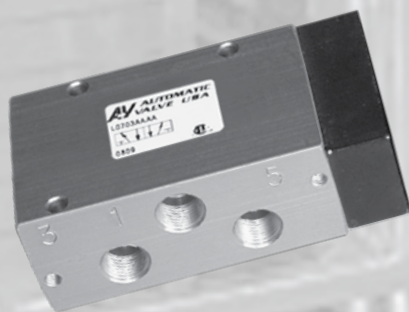
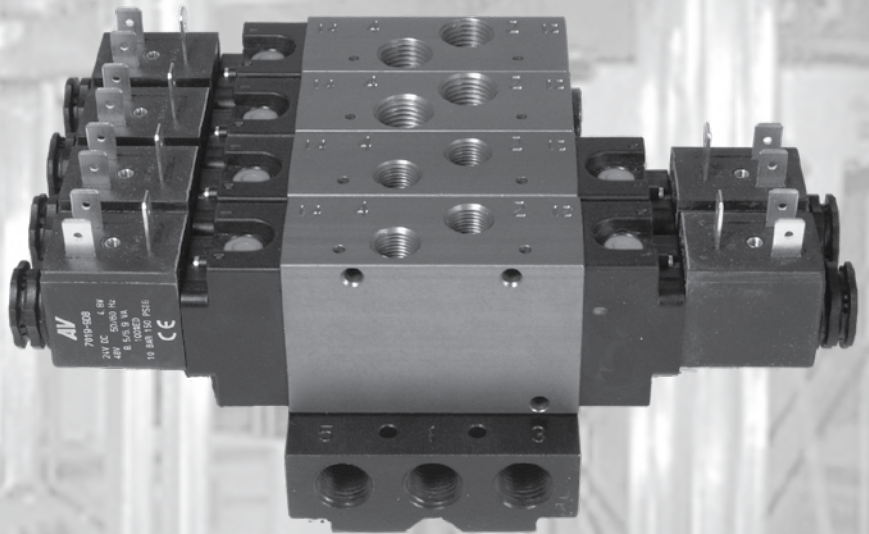

Compact Spool Valves

	Page
Design Features	A2
Specifications	A3
Model Numbers	A3
Standard Solenoid	A4-A5
Air Pilot	A6-A7
Manual & Mechanical	A8-A11
Manifolds	A12-A13
Configuration Example	A14
Electrical Information	A15
Options	A16
Accessories	A16
Service Information	A17

5/2



5/3

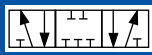

Compact Spool Valves

Design Features

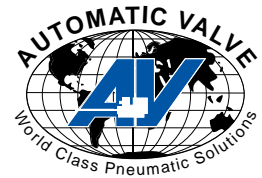

A

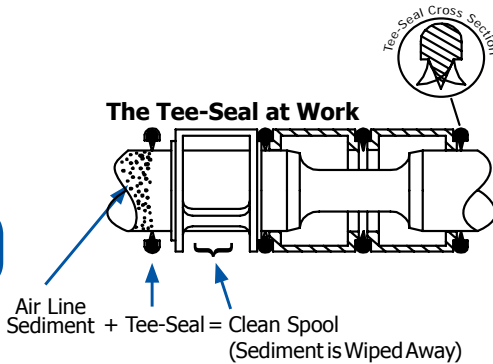

Valves

- Inline or manifold mount: flexible, efficient.
- Balanced spool construction allows ports to be plugged for 2 way or 3 way function, or restricted for inexpensive cylinder exhaust speed control.
- Wide variety of options and operators available.
- Specific application needs? Consult the factory. We will build it for you.



Tapered Tee-Seal Eats Dirt

- Bidirectional tapered Tee-Seal eliminates sticking problems.
 - Flexes to clean spool
 - Mechanically Locked
 - No Spiral Twist
 - No Extrusion
 - Air Line Sediment is Wiped Away.
- Tested tough and proven reliable according to SAE specifications: Rust and water injected every 864,000 cycles for 20 million cycles.



Solenoid ... Guaranteed Against Burnout

- Three-way pilot uses full air line pressure to shift the valve.
- Pilot is internally supplied when the pressure at port one is 35 to 150 PSIG (240 to 1030 kPa).
- Coil is hermetically sealed as an integral watertight molded unit.
- Intrinsically-safe and explosion-proof versions available.
- Push Non-Locking Override is standard. (Extended Turn and Turn-Locking available)



Products Certified To:

- CSA - (C22.2 and UL STD 429)
- Factory Mutual - Explosion Proof Environments
- ATEX - Explosion Proof Environments
- CE - EMF and Low Voltage Directives



Compact Spool Valves Specs & Model Numbers

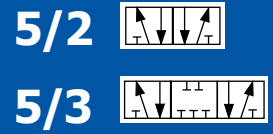

Specifications

Valve Operation		Valve Operation	
<p>5/2 SINGLE De-Energized: Pressure from Port 1 to Port 2 Exhaust from Port 4 to Port 5 Energized: Pressure from Port 1 to Port 4 Exhaust from Port 2 to Port 3</p>		<p>5/3 EXHAUST Maintained Energized 12: Pressure from Port 1 to Port 2 Exhaust from Port 4 to Port 5 De-Energized: Port 2 open to Port 3, Port 4 open to Port 5 Port 1 Blocked Maintained Energized 14: Pressure from Port 1 to Port 4 Exhaust from Port 2 to Port 3</p>	
<p>5/2 DOUBLE Momentarily Energized 12: Pressure from Port 1 to Port 2 Exhaust from Port 4 to Port 5 Momentarily Energized 14: Pressure from Port 1 to Port 4 Exhaust from Port 2 to Port 3</p>		<p>5/3 PRESSURE Maintained Energized 12: Pressure from Port 1 to Port 2 Exhaust from Port 4 to Port 5 De-Energized: Port 1 open to Ports 2 & 4; Ports 3 & 5 Blocked Maintained Energized 14: Pressure from Port 1 to Port 4 Exhaust from Port 2 to Port 3</p>	
Operating Temperatures	Solenoid Pilot Operated	Treated Buna-N Seals (Treated NBR, Standard)	Fluoroelastomer Seals (FPM (FKM), Option A)
	Standard	-18°C to +50°C (0°F to +123°F)	-18°C to +50°C (0°F to +123°F)
	High Temp Coil (Option CT)	-18°C to +82°C (0°F to +180°F)	-18°C to +82°C (0°F to +180°F)
Operating Pressures	Solenoid Pilot Operated	Inlet Port	External Pilot Port
	Standard 2 Position	240 - 1030 kPa (35 - 150 PSIG)	-
	Standard 3 Position	345 - 1030 kPa (50 - 150 PSIG)	-
	External Pilot (Option B)	Vacuum - 240 kPa (Vacuum - 35 PSIG)	240 - 1030 kPa (35 - 150 PSIG)
Filtration & Lubrication	Media - Air Or Inert Gas		
	Air Line Lubrication of Automatic Valve products is not required, but is recommended to maximize service life. Oils should be compatible with seal material, have an ISO 32 viscosity, and have an aniline range between 82°C (180°F) and 99°C (210°F). Filter to 50 microns or better. For temperatures below 40°F, air must be dry to prevent formation of ice. Refer to the Maintenance section of this catalog for recommended lubricants.		

Model Numbers

Series	Body Type	Port Size	Function	Body Design	Operator 1	Center Operator	Operator 2	Voltage ³	Options*
L07	Inline, Manifold	2 1/8 3 1/4	A 4 Way 2 Position	A Single	A Air Pilot	D 3 Pos'n Spring	A Air Pilot	-AA 110/50, 120/60	A Fluoroelastomer Seals
			B 4 Way 2 Position ¹	B Double	F Hand Lever - Line		C 3 Position Spring Manual	-AB 220/50, 240/60, 125VDC	B External Pilot Connection
			C 4 Way 3 Position Block		G Hand Lever - Manifold		M 2 Position Detent Manual	-DA 22/50, 24/60, 12VDC	C Conduit Coil
			D 4 Way 3 Position Exhaust		I Palm Button		N 3 Position Detent Manual	-DB 24VDC	CT Conduit Coil High Temperature
			E 4 Way 3 Position Pressure		J Cam		R 2 Position Spring		D Dustproof
L20	Inline, Manifold	3 1/4 4 3/8			K Foot Pedal			G 18" Flying Leads	
					L Foot Treadle			LL Lowest Watt Coil (0.7Watts) with Type 2 override only	
L65	Inline	6 3/4 7 1			V Intrinsically-Safe Solenoid ² (24VDC only)			S 303 Stainless Steel Body (L20 only)	
					W Weather-Proof Solenoid			SS 316 Stainless Steel Body (L20 only)	
								W G (BSPP) Threads	
								Y Explosion-Proof Coil (CSA, FM)	
								Z Explosion-Proof Coil (ATEX)	
								1 Push Turn-Locking Override	
								2 Extended Turn-Locking Override	
								4 No Override	

* Not all Options are available for all models. Refer to "Options" at the end of this Section for additional information.
¹ Use varies. Consult the Factory for details. ² Can not be used on a manifold. ³ Consult the Factory for additional voltages.

5/2



5/3



Compact Spool Valves Standard Solenoid

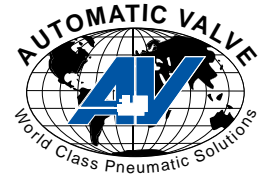

Single

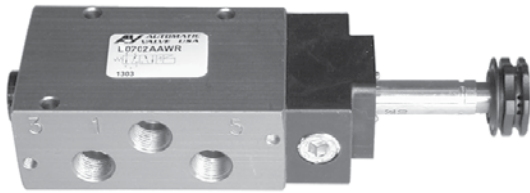

L0702AAWR

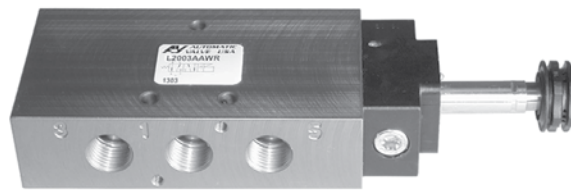

L2003AAWR

Double

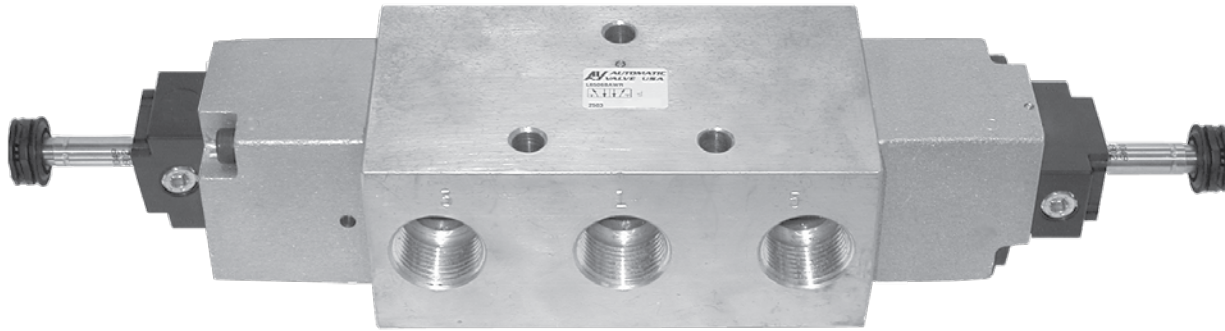

L6506BBWW

Model Numbers

Series	Port Size		Flow l/min (Cv)		5/2		5/3			Body Material	Seal Material	Weight kg (lb)
					Single	Double	Block	Exhaust	Pressure			
L07	1/8		690 (0.7)	538 (0.5)	L0702AAWR-**	L0702ABWW-**	L0702CBWDW-**	L0702DBWDW-**	L0702EBWDW-**	Aluminum	NBR	0,3 (0,6)
	1/4 (1,2,4)	1/8 (3,5)			L0703AAWR-**	L0703ABWW-**	L0703CBWDW-**	L0703DBWDW-**	L0703EBWDW-**			
L20	1/4		1770 (1.8)	1381 (1.4)	L2003AAWR-**	L2003ABWW-**	L2003CBWDW-**	L2003DBWDW-**	L2003EBWDW-**	Aluminum ¹	NBR	0,5 (0,9)
	3/8				L2004AAWR-**	L2004AAWW-**	L2004CBWDW-**	L2004DBWDW-**	L2004EBWDW-**			
L65	3/4		8860 (9.0)	6911 (7.0)	L6506BAWR-**	L6506BBWW-**	L6506CBWDW-**	L6506DBWDW-**	L6506EBWDW-**	Aluminum	NBR	1,86 (4.1)
	1 (1,2,4)	3/4 (3,5)			L6507BAWR-**	L6507BBWW-**	L6507CBWDW-**	L6507DBWDW-**	L6507EBWDW-**			

** = Coil Voltage Code. Coils also sold separately. Refer to "Electrical Information" at the end of this Section for additional information.

¹Body Available in 303 or 316 Stainless Steel (L20 only). Refer to "Options" at the end of this Section for additional information.

Dimensional Information

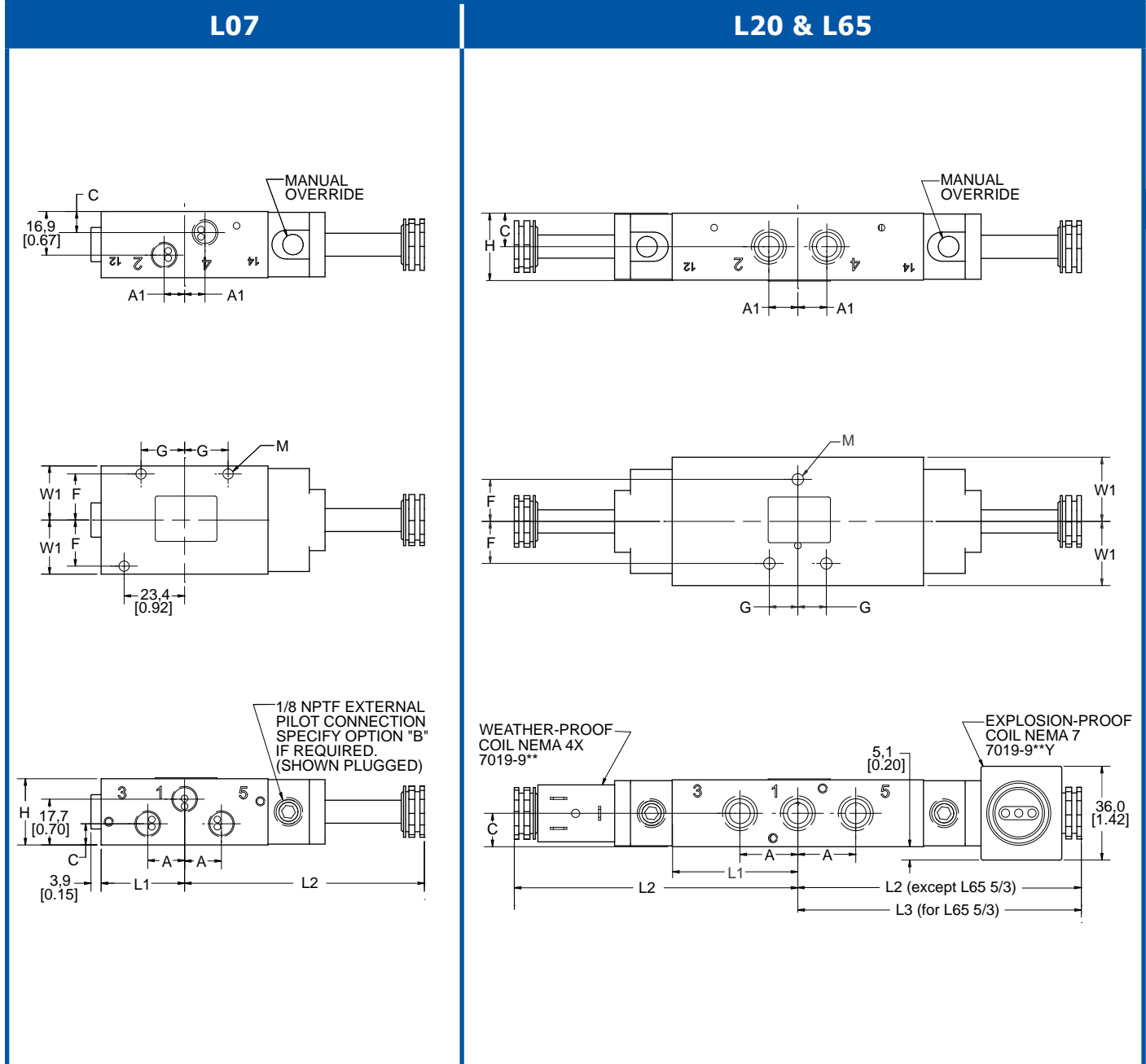

Series	A	A1	C	F	G	H	L1	L2	L3	M	W1
L07	14,3 0.56	7,9 0.31	7,9 0.31	18,3 0.72	16,9 0.66	25,4 1.00	32,3 1.27	92,7 3.65	-	4,0 0.16	21,0 0.83
L20	22,2 0.88	11,1 0.44	12,7 0.50	16,1 0.64	10,9 0.43	25,4 1.00	48,2 1.90	109 4.28	-	4,4 0.17	24,6 0.97
L65	50,8 2.00	25,4 1.00	28,6 1.12	23,4 0.92	25,4 1.00	57,2 2.25	117 4.61	175 6.88	219 8.63	9,14 0.35	36,5 1.44

Units of Measure: Top - mm, Bottom - inches

5/2



5/3

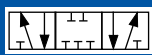

Compact Spool Valves Air Pilot



Single



L0702AAAR



L2003AAAR

Double



L6506BBAA

Model Numbers

Series	Port Size		Flow l/min (Cv)		5/2		5/3		Body Materials	Seal Materials	Wt kg (lb)
			5/2	5/3	Single	Double	Block	Exhaust			
L07	1/8		690 (0.7)	538 (0.5)	L0702AAAR	L0702ABAA	L0702CBADA	L0702DBADA	L0702EBADA	Aluminum NBR	0,3 (0.6)
	1/4 (1,2,4)	1/8 (3,5)			L0703AAAR	L0703ABAA	L0703CBADA	L0703DBADA	L0703EBADA		
L20	1/4		1770 (1.8)	1381 (1.4)	L2003AAAR	L2003ABAA	L2003CBADA	L2003DBADA	L2003EBADA	Aluminum NBR	0,5 (0.9)
	3/8				L2004AAAR	L2004ABAA	L2004CBADA	L2004DBADA	L2004EBADA		
L65	3/4		8860 (9.0)	6911 (7.0)	L6506BAAR	L6506BBAA	L6506CBADA	L6506DBADA	L6506EBADA	Aluminum NBR	1,86 (4.1)
	1 (1,2,4)	3/4 (3,5)	9350 (9.5)	7293 (7.4)	L6507BAAR	L6507BBAA	L6507CBADA	L6507DBADA	L6507EBADA		

Dimensional Information

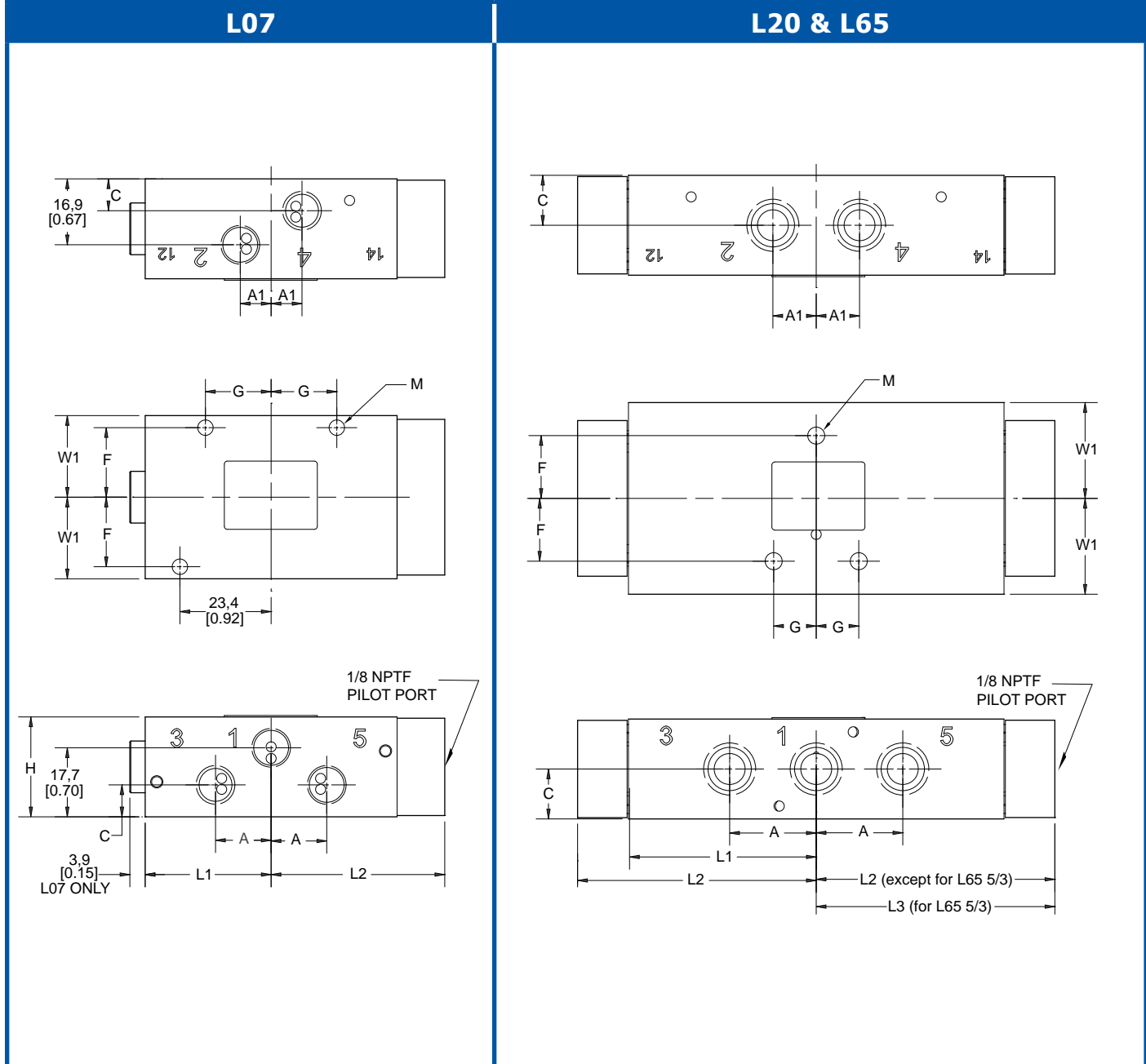

Series	A	A1	C	F	G	H	L1	L2	L3	M	W1
L07	14,3 0.56	7,9 0.31	7,9 0.31	18,3 0.72	16,9 0.66	25,4 1.00	32,3 1.27	45,0 1.77	-	4,0 0.16	21,0 0.83
L20	22,2 0.88	11,1 0.44	12,7 0.50	16,1 0.64	10,9 0.43	25,4 1.00	48,2 1.90	61,0 2.40	-	4,4 0.17	24,6 0.97
L65	50,8 2.00	25,4 1.00	28,6 1.12	23,4 0.92	25,4 1.00	57,2 2.25	115,9 4.56	129 6.81	217 8.56	9,14 0.35	36,5 1.44

Units of Measure: Top - mm, Bottom - inches

5/2



Compact Spool Valves Manual & Mechanical



A

Foot Pedal



L2003AAKR

Foot Treadle



L2003BALM

Palm Button



L2004AAIR

**Hand Lever,
(Manifold Mounted)**

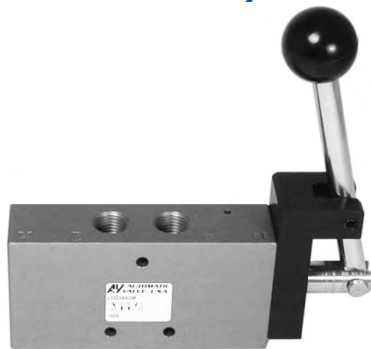

L2003BAGM

Cam Roller



L2003AAJR

Model Numbers

Series	Port Size	Flow (5/2) l/min (Cv)	Operator	5/2		Material		Wt kg (lb)
				Detented	Spring Return	Body	Seal	
L20	1/4	1770 (1.8)	Foot Pedal	-	L2003AAKR	Aluminum	NBR	0,7 (1.1)
			Foot Treadle	L2003BALM	L2003AALR			
			Hand Lever Line Mounted	L2003BAFM	L2003AAFR			
			Hand Lever Manifold Mounted	L2003BAGM	L2003AAGR			
			Palm Button	L2003BAIM	L2003AAIR			
			Cam Roller	-	L2003AAJR			
	3/8	1770 (1.8)	Foot Pedal	-	L2004AAKR	Aluminum	NBR	0,7 (1.1)
			Foot Treadle	L2004BALM	L2004AALR			
			Hand Lever Line Mounted	L2004BAFM	L2004AAFR			
			Hand Lever Manifold Mounted	L2004BAGM	L2004AAGR			
			Palm Button	L2004BAIM	L2004AAIR			
			Cam Roller	-	L2004AAJR			

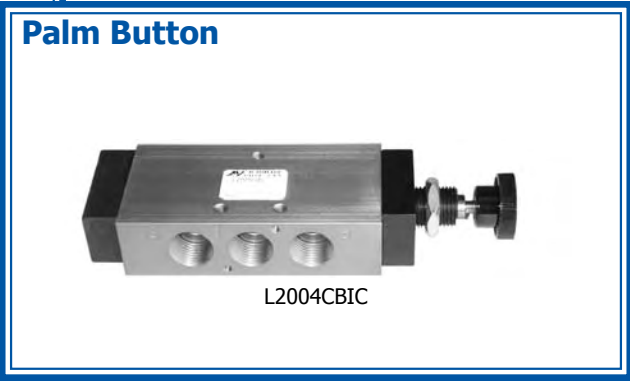

Model Numbers

Series	Port Size	Flow (5/3) 1/min (Cv)	Operator	5/3						Body Material	Seal Material	Weight (lb)
				Detented			Spring Center					
				Block	Exhaust	Pressure	Block	Exhaust	Pressure			
L20	1/4	1381 (1.4)	Foot Treadle	L2003CALN	L2003DALN	L2003EALN	L2003CBLC	L2003DBLC	L2003EBLC	Aluminum	NBR	0,7 (1.5)
			Hand Lever Line Mounted	L2003CAFN	L2003DAFN	L2003EAFN	L2003CBFC	L2003DBFC	L2003EBFC			
			Hand Lever Manifold Mounted	L2003CAGN	L2003DAGN	L2003EAGN	L2003CBGC	L2003DBGC	L2003EBGC			
			Palm Button	L2003CAIN	L2003DAIN	L2003EAIN	L2003CBIC	L2003DBIC	L2003EBIC			
	3/8		Foot Treadle	L2004CALN	L2004DALN	L2004EALN	L2004CBLC	L2004DBLC	L2004EBLC	Aluminum	NBR	0,7 (1.5)
			Hand Lever Line Mounted	L2004CAFN	L2004DAFN	L2004EAFN	L2004CBFC	L2004DBFC	L2004EBFC			
			Hand Lever Manifold Mounted	L2004CAGN	L2004DAGN	L2004EAGN	L2004CBGC	L2004DBGC	L2004EBGC			
			Palm Button	L2004CAIN	L2004DAIN	L2004EAIN	L2004CBIC	L2004DBIC	L2004EBIC			

5/2 

5/3 

Compact Spool Valves

Manual & Mechanical



Dimensional Information

A

Foot Pedal

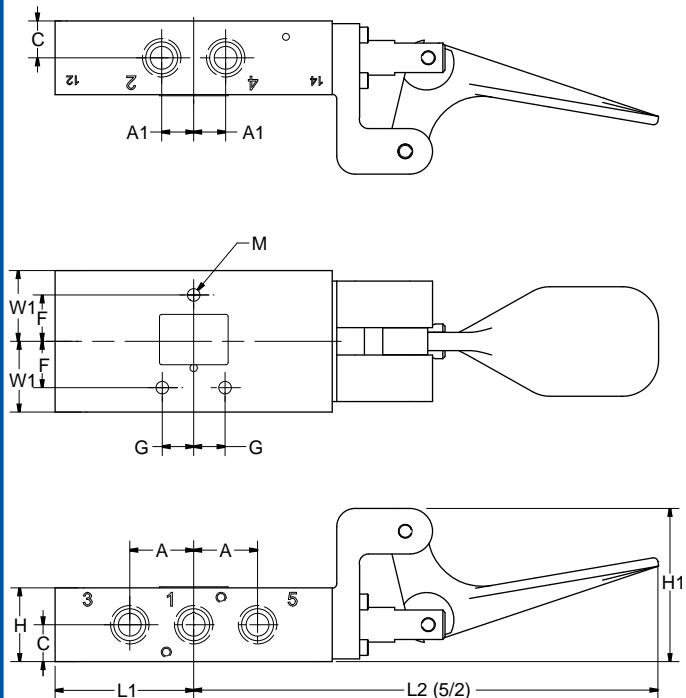

Foot Treadle

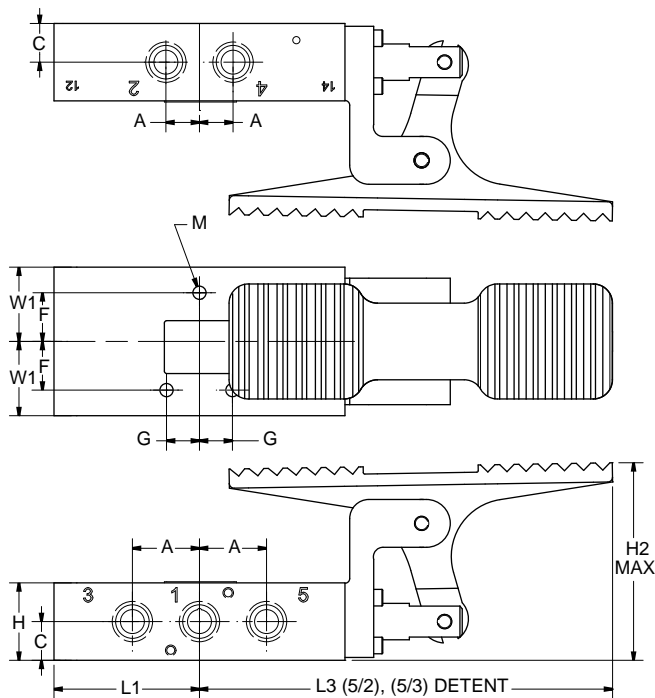

Cam Roller

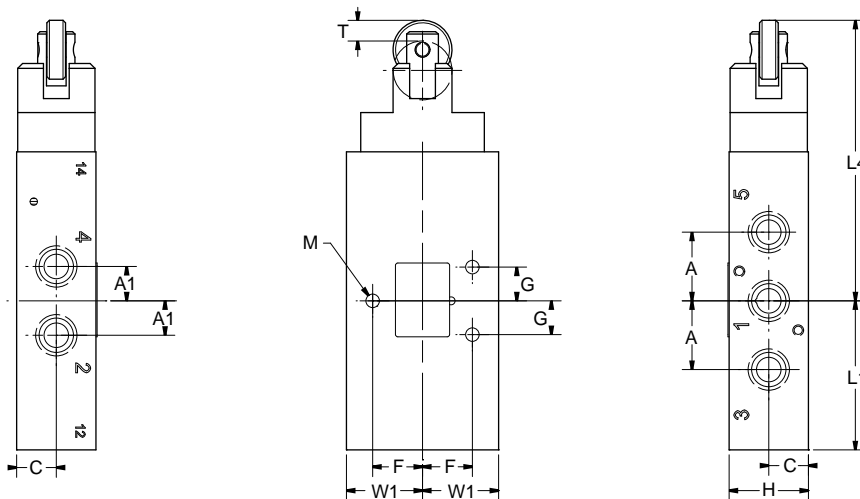

Series	A	A1	C	F	G	H	H1	H2	L1	L4	M	T	W1
L20	22,2 0.88	11,1 0.44	12,7 0.50	16,1 0.64	10,9 0.43	25,4 1.00	52,4 2.06	85,7 3.38	48,2 1.90	90,4 3.56	4,4 0.17	7,6 0.30	24,6 0.97

Units of Measure: Top - mm, Bottom - inches

Dimensional Information

Hand Lever

Line Mounted

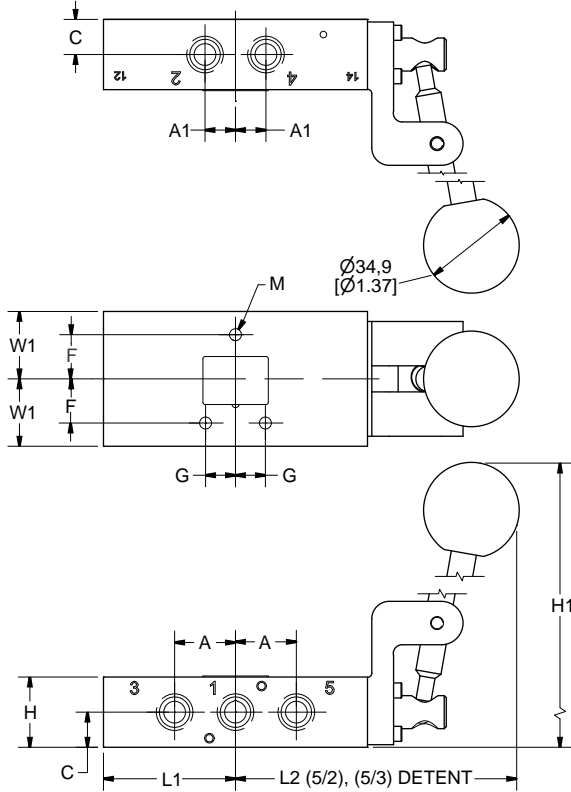

Manifold Mounted

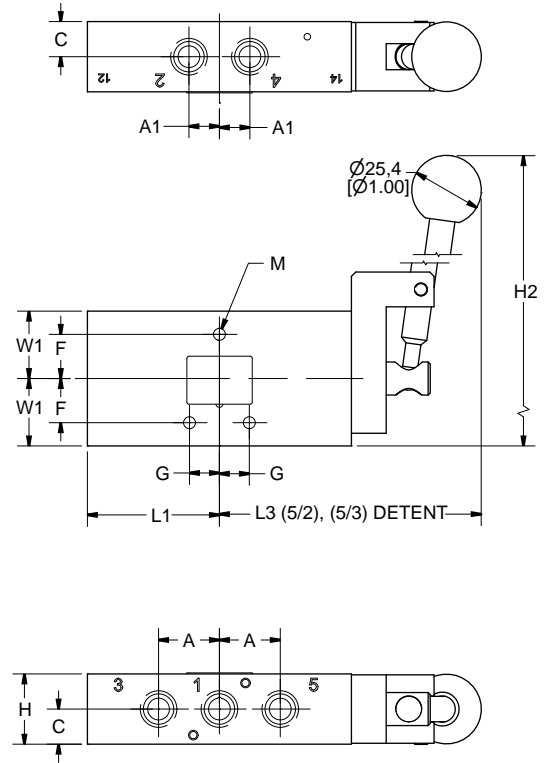

Palm Button

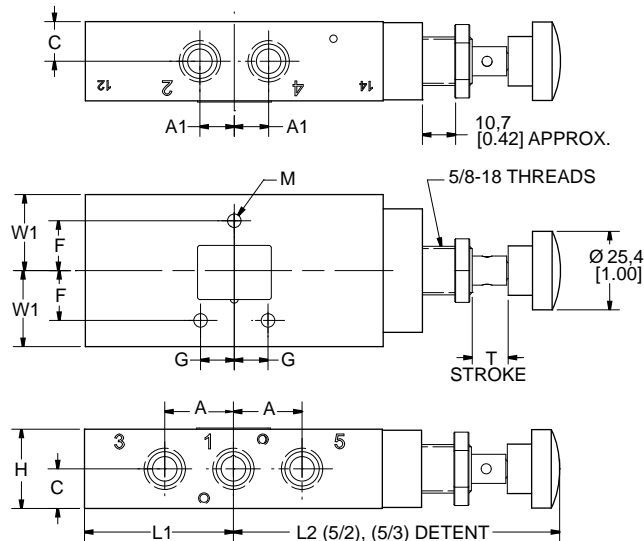

Series	A	A1	C	F	G	H	H1	H2	L1	L2	L3	M	T	W1
L20	22,2 0.88	11,1 0.44	12,7 0.50	16,1 0.64	10,9 0.43	25,4 1.00	136 5.35	140 5.50	48,2 1.90	105 4.14	105 4.14	4,4 0.17	9,5 0.38	24,6 0.97

Units of Measure: Top - mm, Bottom - inches

5/2



5/3

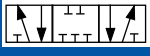

Compact Spool Valves Manifolds



A

Features

- Common inlet and common exhaust ports.
- Top cylinder ports.
- Valve mounting screws attached from bottom.
- Seals and mounting hardware included.

L07

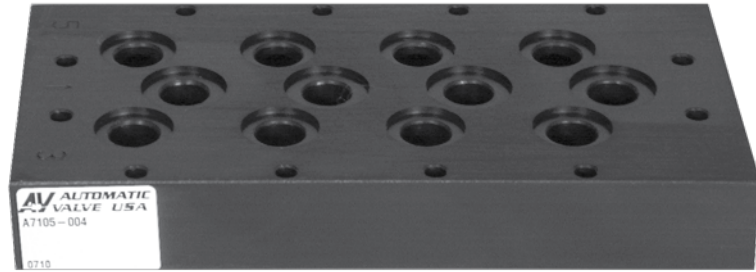

A7105-004

L20

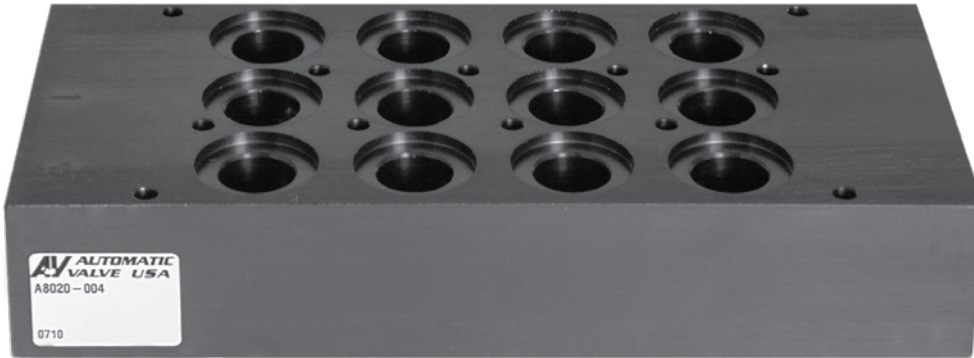

A8020-004

Model Numbers

Series	Manifold*				Accessories	
	No. of Stations	Model Number	Ports 3, 1 & 5	Weight kg (lb)	Blocking Disk	Blank Station Cover
L07	2	A7105-002	1/4	0,2 (0.5)	A7105-202	7105-606
	4	A7105-004		0,36 (0.8)		
	6	A7105-006		0,5 (1.2)		
	8	A7105-008		0,7 (1.6)		
	10	A7105-010		0,9 (2.0)		
L20	2	A8020-002	3/8	0,42 (0.9)	A8020-202	8020-606
	4	A8020-004		0,6 (1.3)		
	6	A8020-006		0,8 (1.7)		
	8	A8020-008		1,0 (2.2)		
	10	A8020-010		1,19 (2.7)		

*Seals and Mounting Hardware included.

Dimensional Information

L07 Manifold

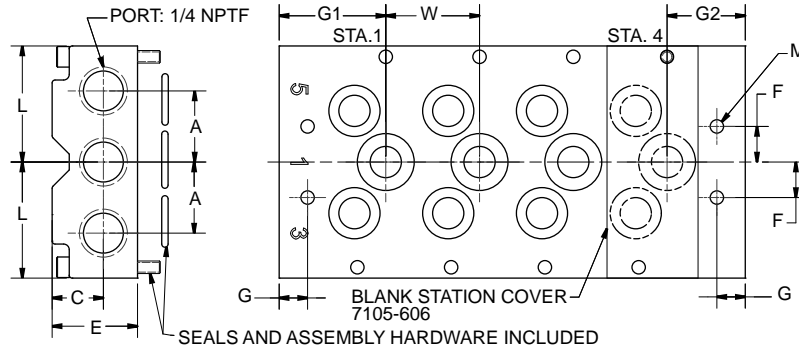

L20 Manifold

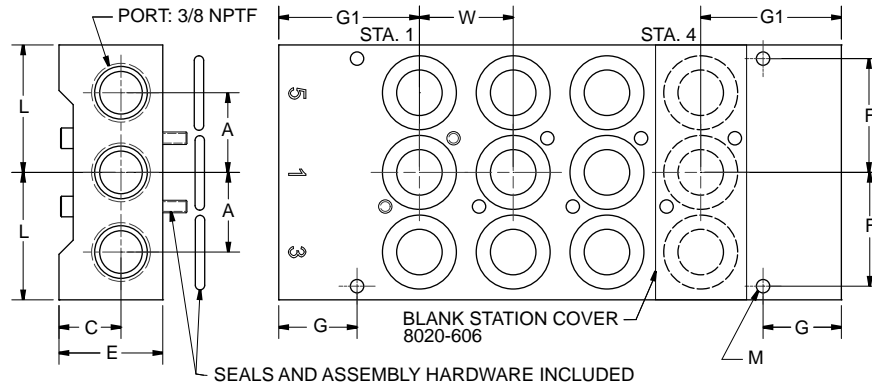

Blocking Disk

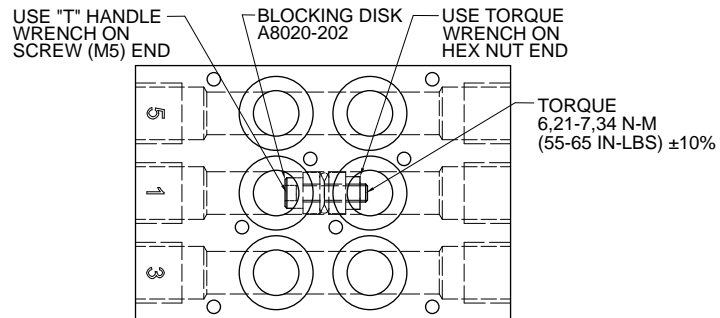

Series	Port Size	A	C	E	F	G	G1	G2	L	M	W
L07	1/4	19,8 0.78	14,3 0.56	23,8 0.94	9,9 0.39	7,9 0.31	29,7 1.17	22,2 0.86	32,4 1.28	3,7 0.15	26,2 1.03
L20	3/8	22,2 0.88	17,3 0.68	31,8 1.25	31,8 1.25	21,8 0.86	39,3 1.55	-	35,6 1.40	3,7 0.15	26,2 1.03

Units of Measure: Top - mm, Bottom - inches

5/2





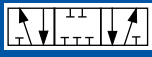



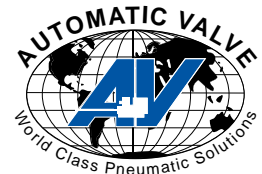

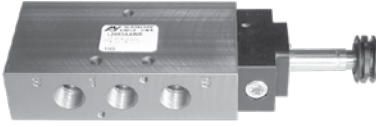

5/3

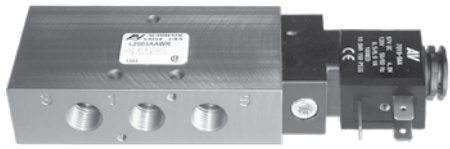

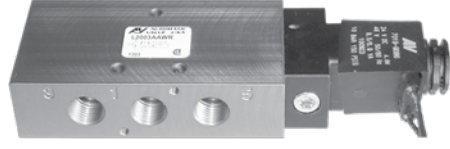
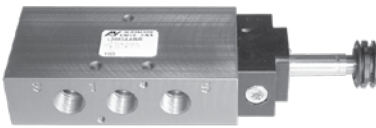
Compact Spool Valves Configuration Example

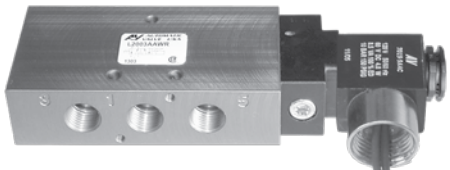
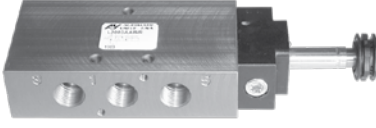

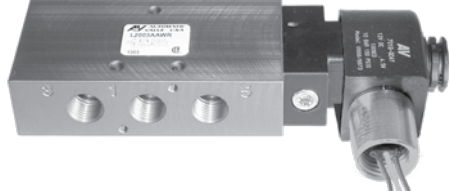
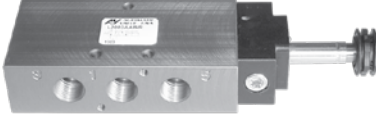
A

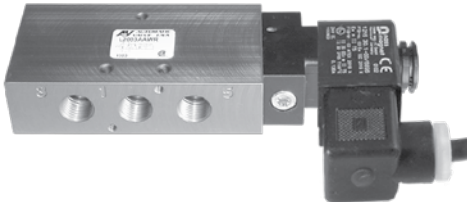
Valve With W-Solenoid Cap	+	Coil	=	Valve With Coil
 <p>L2003AAWR</p>	+	 <p>NEMA 4x with DIN 43650 Form B Connection 7019-9**</p>	=	 <p>L2003AAWR-**</p>
 <p>L2003AAWR</p>	+	 <p>NEMA 4x with 18" Leads 7019-9**G</p>	=	 <p>L2003AAWR-**G</p>
 <p>L2003AAWR</p>	+	 <p>NEMA 4x 1/2" Conduit with 30" Leads 7019-9**C</p>	=	 <p>L2003AAWR-**C</p>
 <p>L2003AAWR</p>	+	 <p>Explosion-Proof 1/2" Conduit with 24" Leads 7019-9**Y</p>	=	 <p>L2003AAWR-**Y</p>
 <p>L2003AAWR</p>	+	 <p>ATEX Explosion-Proof with 39" Cable 7152-9**</p>	=	 <p>L2003AAWR-**Z</p>



Compact Spool Valves

Electrical Information

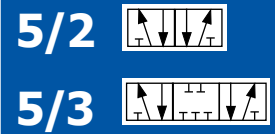

Compact Spool Valves

A

Part Numbers

Description	Operator Type	Instructions	Wt. Kg(lb)	Coil Part Number **=Voltage
Weather-Proof DIN 43650 Industrial Form B Connection NEMA 4X	W	Order coil separately (specify voltage code from below)	0,05 (0.12)	7019-9**
Weather-Proof 18" Leads NEMA 4X	W	Order coil separately (specify voltage code from below)	0,05 (0.12)	7019-9**G
Weather-Proof 1/2" Conduit with 30" Leads NEMA 4X	W	Order coil separately (specify voltage code from below)	0,05 (0.12)	7019-9**C 7019-9**CT (high temp 82°C max)
Explosion-Proof 1/2" Conduit with 24" Leads CSA & FM Approved CL. I; Zone1 ExmII T4; AExmII CL. I; Div.1; GR. A, B, C, D CL. II; GR. E, F, G CL. III T4 Ta=-20°C to +60°C NEMA 4, 4X, 7C, 7D, 9	W	Order coil separately (specify voltage code from below)	0,20 (0.44)	7019-9**Y
Intrinsically-Safe Strain Relief Ex ia CL. I; GR. A, B, C, D CL. II; GR. E, F, G CL. III; Div.1; T5	V	Coil and Connector included with valve (24VDC only)	0,21 (0.46)	A7106-374-DB
A7106-374 Must be Used with an Intrinsically-Safe Barrier For more information refer to "Intrinsic Safety" insert on Page D7.				
Explosion-Proof 3m Cable & Strain Relief Ex m II T5 PTB 03 ATEX2018 X EX II 2 G EEx m II T5 EX II 2 D IP65 T95°C	Z	Order coil separately (specify voltage code from below)	0,36 (0.78)	7152-9**

Voltage Codes (Lower wattage options available, consult factory)

** Code	Voltage +/- 10%		Current (Amps)								Resistance (OHMS @ 25°C)				Power (AC=VA, DC=Watts)							
	Operator Type:		Inrush				Holding				W		V		Z		W		V		Z	
			W		V		Z		W													
	NEMA 4	NEMA 7,9 & ATEX	NEMA		ATEX		NEMA		ATEX		NEMA		ATEX		NEMA		ATEX					
4, 4x			7, 9	Exia	Exm	4, 4x	7, 9	Exia	Exm	4, 4x	7, 9	Exia	Exm	4, 4x	7, 9	Exia	Exm					
DA	24/50 24/60	-	.36	-	-	-	.24	-	-	-	32	-	-	-	6.9	-	-	-				
AA	120/50 120/60	120/60	.08	.10	-	.04	.05	.05	-	.03	840	530	-	1664	6.9	6.5	-	3.4				
AB	230/50 230/60	240/60	.04	.05	-	.02	.03	.03	-	.01	3310	2345	-	6730	6.4	6.8	-	3.3				
DA	12 VDC	12VDC	.38	.38	-	.27	.38	.38	-	.27	32	32	-	45	4.8	4.5	-	3.5				
DB	24 VDC	24VDC	.20	.19	.05	.14	.20	.19	.05	.14	121	128	275	177	4.8	4.5	1.6	3.5				
AB	125 VDC	-	.04	-	-	-	.04	-	-	-	3310	-	-	-	5.9	-	-	-				

Connectors (Not polarity dependent)

DIN 43650 Industrial Form B	Maximum Cable Diameter: 9mm (0.35")		Strain Relief with Light		1/2" Conduit without Cord	Molded with 6' Cord	Strain Relief with Light & 6' Cord	
Type	Strain Relief without Cord	100-240 AC 48-120 DC	6-48 AC/DC	100-240 AC 48-120 DC	6-48 AC/DC	100-240 AC 48-120 DC	6-48 AC/DC	
Part Number	7020-001	7020-AA	7020-DB	7039-001	7020-006	7094-006	7094-007	

5/2



5/3

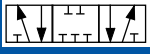

Compact Spool Valves Options & Accessories

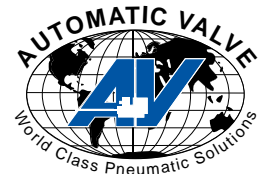

Options (Add the suffix to the end of the Model Number in alpha-numeric order)

Suffix	Option	Description
A	Fluoroelastomer Seals	For applications where fluid media or ambient conditions are not compatible with nitrile seals. <i>Note: Fluorocarbon seals do not increase the effective temperature range of the valve. For high temperature applications, consult the factory.</i>
B	External Pilot	For solenoid applications where the pressure to port one is less than 2 BAR (35 PSIG). See example below for field conversion.
		<p style="text-align: center;">Field Conversion</p> <ul style="list-style-type: none"> Remove solenoid and cap from the valve body. Rotate the gasket 180° so that the internal pilot hole in the valve body is covered by the gasket. Refasten the gasket, cap and solenoid to the valve body. Make sure the gasket completely covers the internal pilot hole before tightening the M3 screws. Torque to 1,02 N-m (9 in-lbs) ±10%. Remove the 1/8 NPTF pipe plug from the cap and make the external pilot connection.
C	Conduit Coil	Refer to the "Electrical Information" page in this section for details.
CT	Conduit Coil High Temperature	Refer to the "Electrical Information" page in this section for details.
D	Dustproof	For applications in extremely dusty and contaminated environments. Vent ports are plugged and spring pad breather vent is eliminated.
G	Coil With 18" Leads	Refer to the "Electrical Information" page in this section for details.
L	Low Watt Coil	Power Consumption = 2.5 Watts. Standard as Push Non-Locking Override. Also available with Option 2, Extended Turn-Locking Override.
LL	Lowest Watt Coil	Power Consumption = 0.7 Watts. Standard as Extended Turn-Locking Override.
S	303 Stainless Steel	303 Stainless Steel body, all other external parts are corrosion resistant; for corrosive environment applications. (L20 only)
SS	316 Stainless Steel	316 Stainless Steel body, all other external parts are corrosion resistant; for corrosive environment applications. (L20 only)
W	G Threads	All ports tapped to metric "G" standard (for 3/8", 3/4", 1"). Not required for 1/8" or 1/4" ports, which use a universal G/NPT tap.
Y	Explosion-Proof Coil (CSA, FM)	Refer to the "Electrical Information" page in this section for details.
Z	Explosion-Proof Coil (Atex, PTB)	Refer to the "Electrical Information" page in this section for details.
1	Push Turn-Locking Override	Solenoid cap provides an override that is pushed in and turned to actuate & lock in the "on" position.
2	Extended Turn-Locking Override	Solenoid cap provides an extended override that is turned to lock in the "on" position.
4	No Override	Solenoid cap does not provide a manual override.

Accessories

Interposed Flow Control

- Restricts air flow from port 2 to port 3 and from port 4 to port 5.
- Mounts between the valve and the manifold.

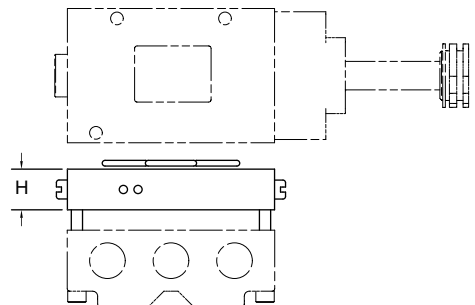
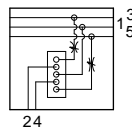

Series	Model Number	Dimension H	Weight Kg (lb)
L07	B7106-005	12,7 0.50	0,06 (0.14)
L20	B8022-005	12,7 0.50	0,09 (0.19)

Valve must be disconnected from all air and electrical power sources before disassembly.

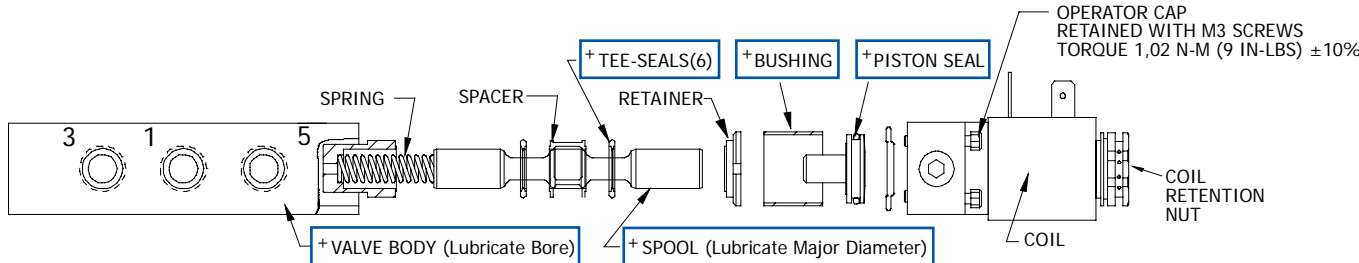

Shown: L20 Single 2 Position Valve

+ = Items that Must Be Lubricated

Service Kit Installation Instructions

1. Follow appropriate lock-out/tag-out procedures. Do not attempt to service a valve, if you are not familiar with lock-out/tag-out procedures.
2. Turn off electrical power to the valve.
3. Remove valve from all electrical and air power sources.
4. Ensure all stored air power is exhausted.
5. Remove coil by first removing the coil retention nut.
6. Remove the operator cap by first removing the 4 socket head cap screws.
7. Remove existing serviceable components by "pushing" internal components gently out of the valve body.
8. Clean the spool with a clean cloth.
9. Discard the spring (Single Spring Return models only).
10. Lubricate the designated items in the above assembly drawing with a thin film of lubricant - the item should look "WET" with no excess lubricant visible.
11. Replace components as shown above.
 - 11.1 Replace spring pad and spring (Single Spring Return models only).
 - 11.2 Alternate Tee-seals and spacers.
 - 11.3 Once all 6 Tee-seals are installed, replace the retainer, bushing and piston.
12. Orientate the operator cap by aligning the open end of the gasket with the pilot hole in the valve body.
13. Torque cap screws into body to 1,02 N-m (9 in-lbs) ±10%. Alternate tightening of the screws, so cap "squeezes" evenly onto the body.

Air Line Lubrication of Automatic Valve products is not required, but is recommended to maximize service life. Oils should be compatible with seal material, have an ISO 32 or lighter viscosity, and have an aniline point between 82°C (180°F) and 99°C (210°F). Refer to the Maintenance Section of this catalog for recommended lubricants.

Model Numbers: Service Kits

Series	Body Style		
	Description	Model Number	Contents
L07	Single	K-L07-SGL K-L07-SGL-A (Fluoroelastomer)	Tee-Seals (6), Piston Seal (1), Spring (1), Lubricant
	Double	K-L07-DBL K-L07-DBL-A (Fluoroelastomer)	Tee-Seals (6), Piston Seals (2), Lubricant
L20	Single	K-L20-SGL K-L20-SGL-A (Fluoroelastomer)	Tee-Seals (6), Piston Seal (1), Spring (1), Lubricant
	Double	K-L20-DBL K-L20-DBL-A (Fluoroelastomer)	Tee-Seals (6), Piston Seals (2), Lubricant
L65	Single	K-L65-SGL K-L65-SGL-A (Fluoroelastomer)	Tee-Seals (6), Piston Seal (1), Spring (1), Lubricant
	Double	K-L65-DBL K-L65-DBL-A (Fluoroelastomer)	Tee-Seals (6), Piston Seals (2), Lubricant

AV AUTOMATIC VALVE

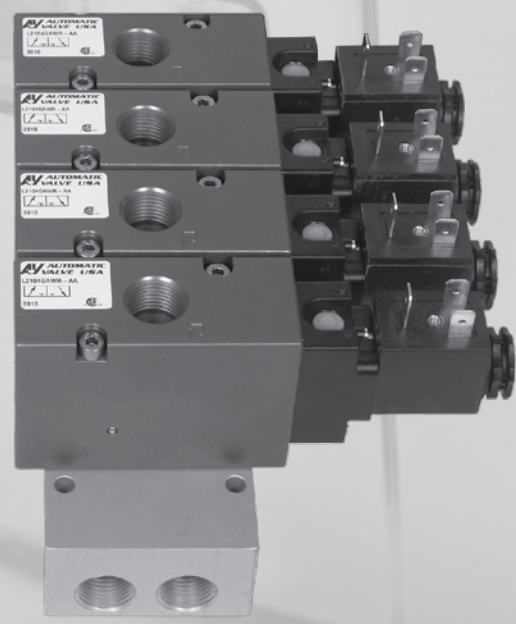

3 Way Compact Spool Valves

	Page
Design Features	B2
Specifications	B3
Model Number	B3
How to Read the Model Number Charts	B3
Standard Solenoid	B4-B5
Air Pilot	B6-B7
Manual	B8-B9
Lockout	B8-B9
Top Mount	B10-B11
Manifolds	B10-B11
Configuration Example	B12
Electrical Information	B13
Options	B14

3/2



3 Way Compact Spool Valves

Design Features

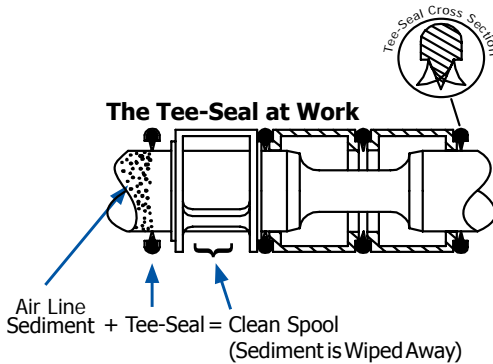
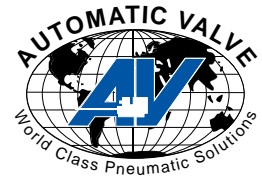

Valves

- Compact size, high flow.
- Inline or manifold mount (L21 only): flexible, efficient.
- Wide variety of options and operators available.
- Lockout tested and approved to SAE specifications.
- Specific application needs? Consult the factory. We will build it for you.

B



Tapered Tee-Seal Eats Dirt

- Bidirectional tapered Tee-Seal eliminates sticking problems.
 - Flexes to clean spool
 - Mechanically Locked
 - No Spiral Twist
 - No Extrusion
 - Air Line Sediment is Wiped Away.
- Tested tough and proven reliable according to SAE specifications: Rust and water injected every 864,000 cycles for 20 million cycles.



Solenoid ... Guaranteed Against Burnout

- Three-way pilot uses full air line pressure to shift the valve.
- Pilot is internally supplied when the pressure at port one is 35 to 150 PSIG (240 to 1030 kPa).
- Coil is hermetically sealed as an integral watertight molded unit.
- Intrinsically-safe and explosion-proof versions available.
- Push Non-Locking Override is standard. (Extended Turn and Turn-Locking available)



Products Certified To:

- CSA - (C22.2 and UL STD 429)
- Factory Mutual - Explosion Proof Environments
- ATEX - Explosion Proof Environments
- CE - EMF and Low Voltage Directives

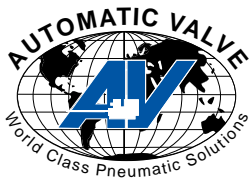

3 Way Compact Spool Valves Specs & Model Numbers

3/2



Specifications

Valve Operation		Valve Operation	
<p>L20 L45</p>		<p>3/2 DOUBLE Momentarily Energized 10: Exhausts Pressure from Port 2 to Port 3 Blocks Pressure at Port 1 Momentarily Energized 12: Pressure from Port 1 to Port 2</p>	
<p>3/2 Normally Closed De-Energized: Exhausts Pressure from Port 2 to Port 3 Blocks Pressure at Port 1 Energized: Pressure from Port 1 to Port 2</p>		<p>3/2 Normally Open De-Energized: Pressure from Port 1 to Port 2 Energized: Exhausts Pressure from Port 2 to Port 3 Blocks Pressure at Port 1</p>	
Operating Temperatures 	Solenoid Pilot Operated	Treated Buna-N Seals (Treated NBR, Standard)	Fluoroelastomer Seals (FPM (FKM), Option A)
	Standard	-18°C to +50°C (0°F to +123°F)	-18°C to +50°C (0°F to +123°F)
Operating Pressures 	Solenoid Pilot Operated	Inlet Port	External Pilot Port
	Standard 2 Position	240 - 1030 kPa (35 - 150 PSIG)	-
Filtration & Lubrication 	Media - Air Or Inert Gas		
	Air Line Lubrication of Automatic Valve products is not required, but is recommended to maximize service life. Oils should be compatible with seal material, have an ISO 32 viscosity, and have an aniline range between 82°C (180°F) and 99°C (210°F). Filter to 50 microns or better. For temperatures below 40°F, air must be dry to prevent formation of ice. Refer to the Maintenance section of this catalog for recommended lubricants.		

Model Numbers

Series	Body Type	Port Size	Function	Body Design	Operator 1	Operator 2	Voltage ²	Options*
L20	0 Inline	3 1/4 4 3/8	G 3 WAY NC H 3 WAY NO	A Single B Double	A Air Pilot	A Air Pilot	-AA 110/50, 120/60 -AB 220/50, 240/60, 125VDC -DA 22/50, 24/60, 12VDC -DB 24VDC	B External Pilot Connection
					F Hand Lever - Line	M 2 Position Detent Manual		C Conduit Coil
					I Palm Button	R 2 Position Spring		CT Conduit Coil High Temperature
L45	0 Inline	5 1/2			V Intrinsically-Safe Solenoid ¹ (24VDC only)	V Intrinsically-Safe Solenoid ¹ (24VDC only)		D Dustproof
					W Weather-Proof Solenoid	W Weather-Proof Solenoid		G 18" Flying Leads
L21	0 Inline, Manifold	3 1/4 4 3/8			V Intrinsically-Safe Solenoid ¹ (24VDC only)	V Intrinsically-Safe Solenoid ¹ (24VDC only)		L Low Watt Coil (2.5 Watts)
					W Weather-Proof Solenoid	W Weather-Proof Solenoid		LL Lowest Watt Coil (0.7 Watts) with Type 2 override only (24VDC only)

Series	Body Type	Port Size	Function	Body Design	Operator 1	Operator 2	Voltage	Options*
L45 Lockout	0 Inline	5 1/2 6 3/4	H 3 WAY NO	A Single	L Lockout	M Detent - Lockout		A Fluoroelastomer Seals

*Not all Options are available for all models. Refer to "Options" at the end of this Section for additional information.
¹ Can not be used on a manifold. ² Consult the Factory for additional voltages.

How to Read the Model Number Chart

The model number digits are in the shaded columns, descriptions of each digit are in the white columns.
 Example of L2003GAWR-AAAB: L20 Series inline valve (body type) with 1/4" ports, 3 way normally closed (function) single body with a weather-proof solenoid, 2 position spring return, 110 volt din coil, and an external pilot connection.

Series	Body Type	Port Size	Function	Body Design	Operator 1	Operator 2	Voltage*	Options*
L20	0 Inline	3 1/4	G 3 WAY NC	A Single	W Weather-Proof Solenoid	R 2 Position Spring	-AA 110/50, 120/60	B External Pilot Connection

3/2



3 Way Compact Spool Valves Standard Solenoid

B

Single



L2003GAWR



L2003GAVR-DB
Intrinsically-Safe, 24 VDC only
(connector included, not shown)

Double



L4505GBWW



L4505GBVV-DB
Intrinsically-Safe, 24 VDC only
(connector included, not shown)

Model Numbers

Series	Operator	Port Size	Flow l/min (Cv)	3 Way Normally Closed		3 Way Normally Open		Mat'l		Wt Kg (lb)
				Single	Double	Single	Double	Body	Seal	
L20	Weather-Proof and Explosion-Proof	1/4	1770 (1.8)	L2003GAWR-**	L2003GBWW-**	L2003HAWR-**	L2003HBWW-**	Aluminum	NBR	0,27 (0.6)
		3/8		L2004GAWR-**	L2004GBWW-**	L2004HAWR-**	L2004HBWW-**			
	Intrinsically-Safe	1/4		L2003GAVR-DB	L2003GBVV-DB	L2003HAVR-DB	L2003HBVV-DB			0,4 (0.9)
		3/8		L2004GAVR-DB	L2004GBVV-DB	L2004HAVR-DB	L2004HBVV-DB			
L45	Weather-Proof and Explosion-Proof	1/2	3940 (4.0)	L4505GAWR-**	L4505GBWW-**	L4505HAWR-**	L4505HBWW-**	0,68 (1.5)		
				Intrinsically-Safe	L4505GAVR-DB	L4505GBVV-DB	L4505HAVR-DB		L4505HBVV-DB	0,86 (1.9)

** = Coil Voltage Code. Coils also sold separately. Refer to "Electrical Information" at the end of this Section for additional information.



Dimensional Information

Single

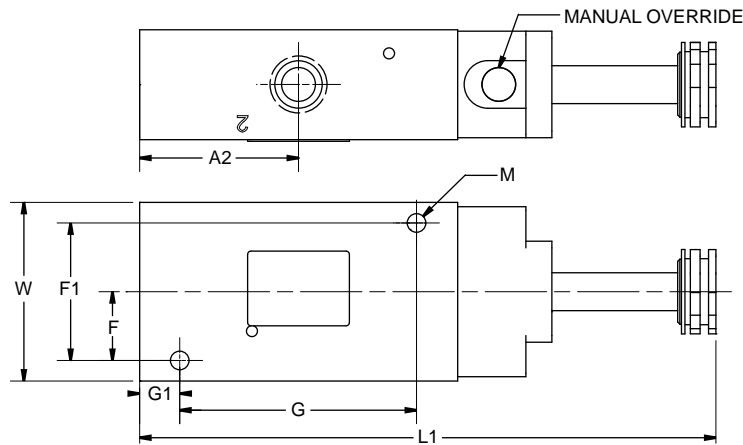

Double

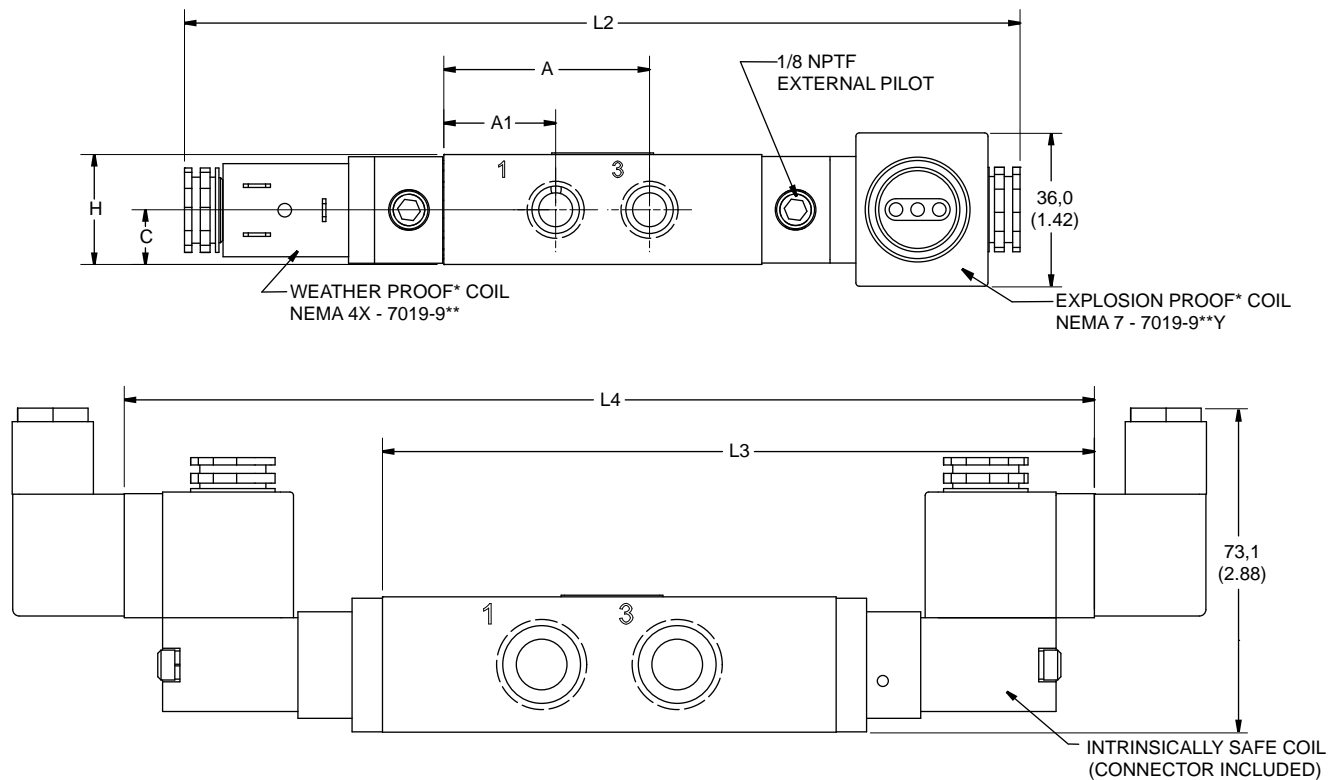

Series	A	A1	A2	C	F	F1	G	G1	H	L1	L2	L3	L4	M	W
L20	48,2 1.90	26,2 1.03	37,3 1.47	12,7 0.50	16,1 0.64	32,3 1.27	55,6 2.19	9,7 0.38	25,4 1.00	135 5.32	196 7.70	127 5.00	179 7.06	4,3 0.17	41,9 1.65
L45	69,1 2.72	37,3 1.47	53,1 2.09	16,0 0.63	23,9 0.94	47,8 1.88	69,8 2.75	18,3 0.72	31,8 1.25	174 6.87	241 9.49	166 6.54	225 8.88	6,6 0.26	63,5 2.50

Units of Measure: Top - mm, Bottom - inches

3/2

3 Way Compact Spool Valves

Air Pilot

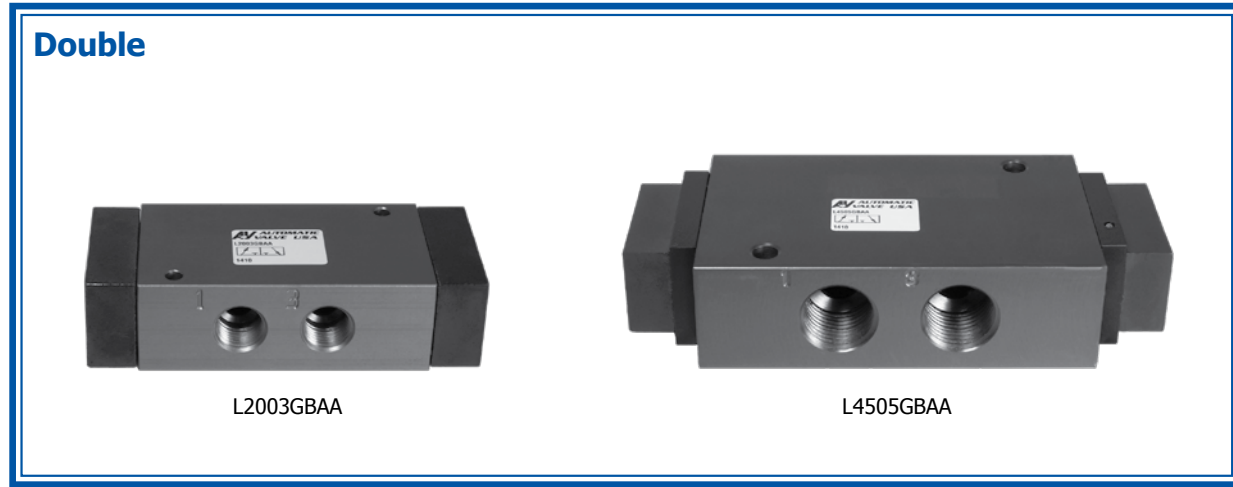

Model Numbers

Series	Port Size	Flow l/min (Cv)	3 Way Normally Closed		3 Way Normally Open		Materials		Wt Kg (lb)
			Single	Double	Single	Double	Body	Seal	
L20	1/4	1770 (1.8)	L2003GAAR	L2003GBAA	L2003HAAR	L2003HBAA	Aluminum	NBR	0,4 (0.9)
	3/8		L2004GAAR	L2004GBAA	L2004HAAR	L2004HBAA			
L45	1/2	3940 (4.0)	L4505GAAR	L4505GBAA	L4505HAAR	L4505HBAA			



Dimensional Information

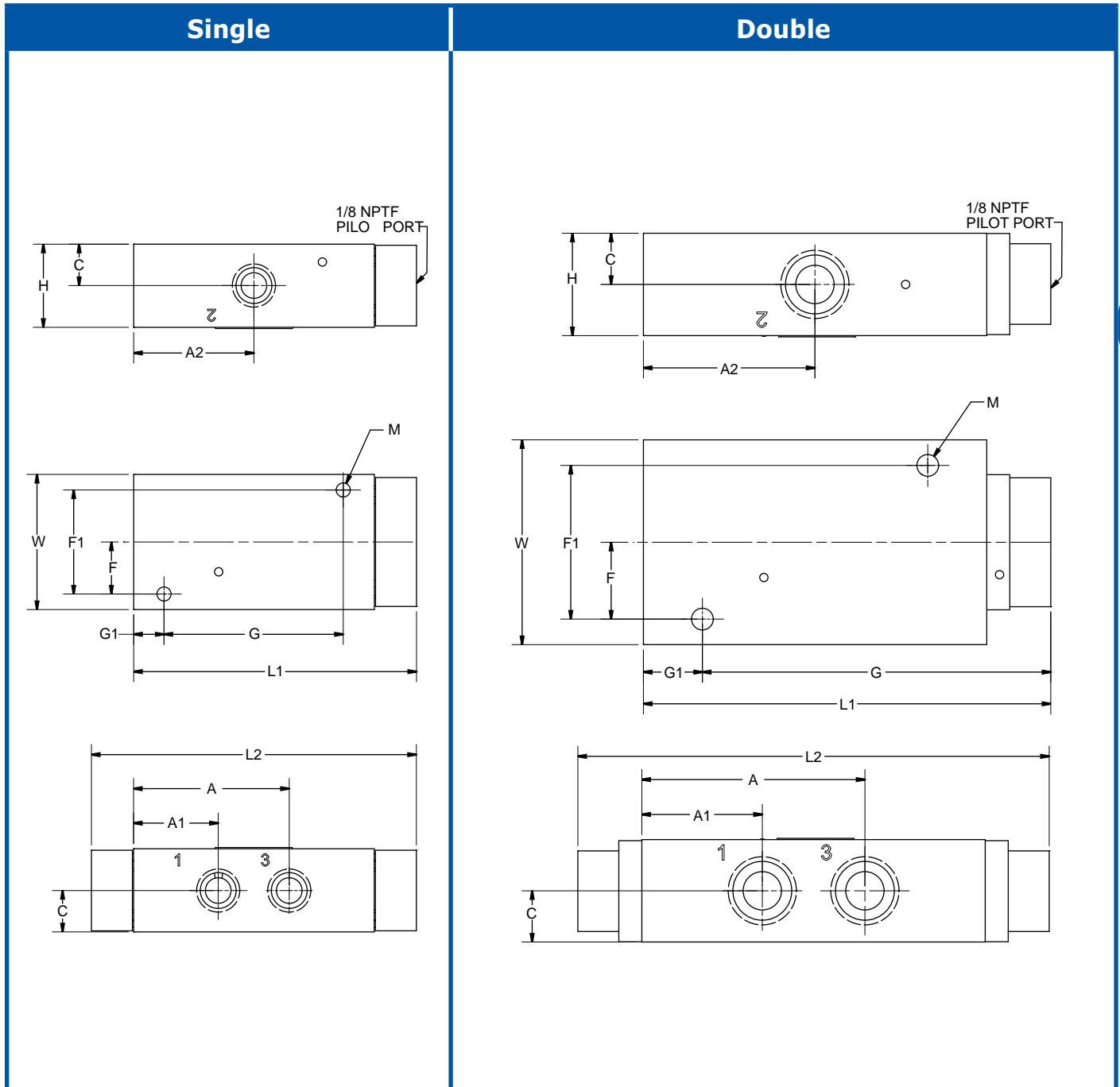

Series	A	A1	A2	C	F	F1	G	G1	H	L1	L2	M	W
L20	48,3 1.90	26,2 1.03	37,3 1.47	12,7 0.50	16,1 0.64	32,3 1.27	55,5 2.19	9,7 0.38	25,4 1.00	87,7 3.45	101 3.97	4,4 0.17	41,9 1.65
L45	69,1 2.72	37,3 1.47	53,1 2.09	16,0 0.63	23,9 0.94	47,8 1.88	69,8 2.75	18,3 0.72	31,8 1.25	126 4.97	146 5.75	6,6 0.26	63,5 2.50

Units of Measure: Top - mm, Bottom - inches

3/2



3 Way Compact Spool Valves

Manual and Lockout

Palm Button



L2003GAIM

Lockout

- Short stroke for quick response.
- Bright red handle for visibility.
- Can be Padlocked in the closed position.
- When handle is pulled outward, Inlet Port 1 is connected to Outlet Port 2, and Exhaust Port 3 is blocked.
- When handle is pushed inward, Inlet Port 1 is blocked, and Outlet Port 2 is connected to Exhaust Port 3.

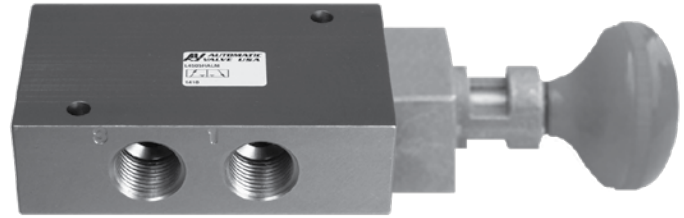

L4505HALM

Hand Lever (Line Mounted)



L4505GAFM

Foot Pedal

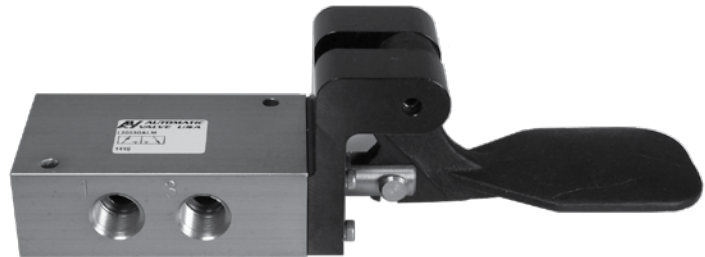

L2003GAKR

Model Numbers

Body Type	Operator	Port Size	Flow l/min (Cv)	3 Way Normally Closed		3 Way Normally Open		Materials		Wt Kg (lb)	
				Detented	Spring Return	Detented	Spring Return	Body	Seal		
L20	Foot Pedal	1/4	1770 (1.8)	-	L2003GAKR	-	L2003HAKR	Aluminum	NBR	0,4 (0.9)	
		3/8		-	L2004GAKR	-	L2004HAKR				
	Hand Lever Line Mounted	1/4		L2003GAFM	L2003GAFR	L2003HAFM	L2003HAFR				
		3/8		L2004GAFM	L2004GAFR	L2004HAFM	L2004HAFR				
	Palm Button	1/4		L2003GAIM	L2003GAIR	L2003HAIM	L2003HAIR				
		3/8		L2004GAIM	L2004GAIR	L2004HAIM	L2004HAIR				
L45	Foot Pedal	1/2	3940 (4.0)	-	L4505GAKR	-	L4505HAKR	Aluminum	NBR	0,9 (1.9)	
	Hand Lever Line Mounted			L4505GAFM	L4505GAFR	L4505HAFM	L4505HAFR				
	Palm Button			L4505GAIM	L4505GAIR	L4505HAIM	L4505HAIR				
	Lockout			1/2	-	-	L4505HALM				-
				3/4	-	-	L4506HALM				-



Dimensional Information

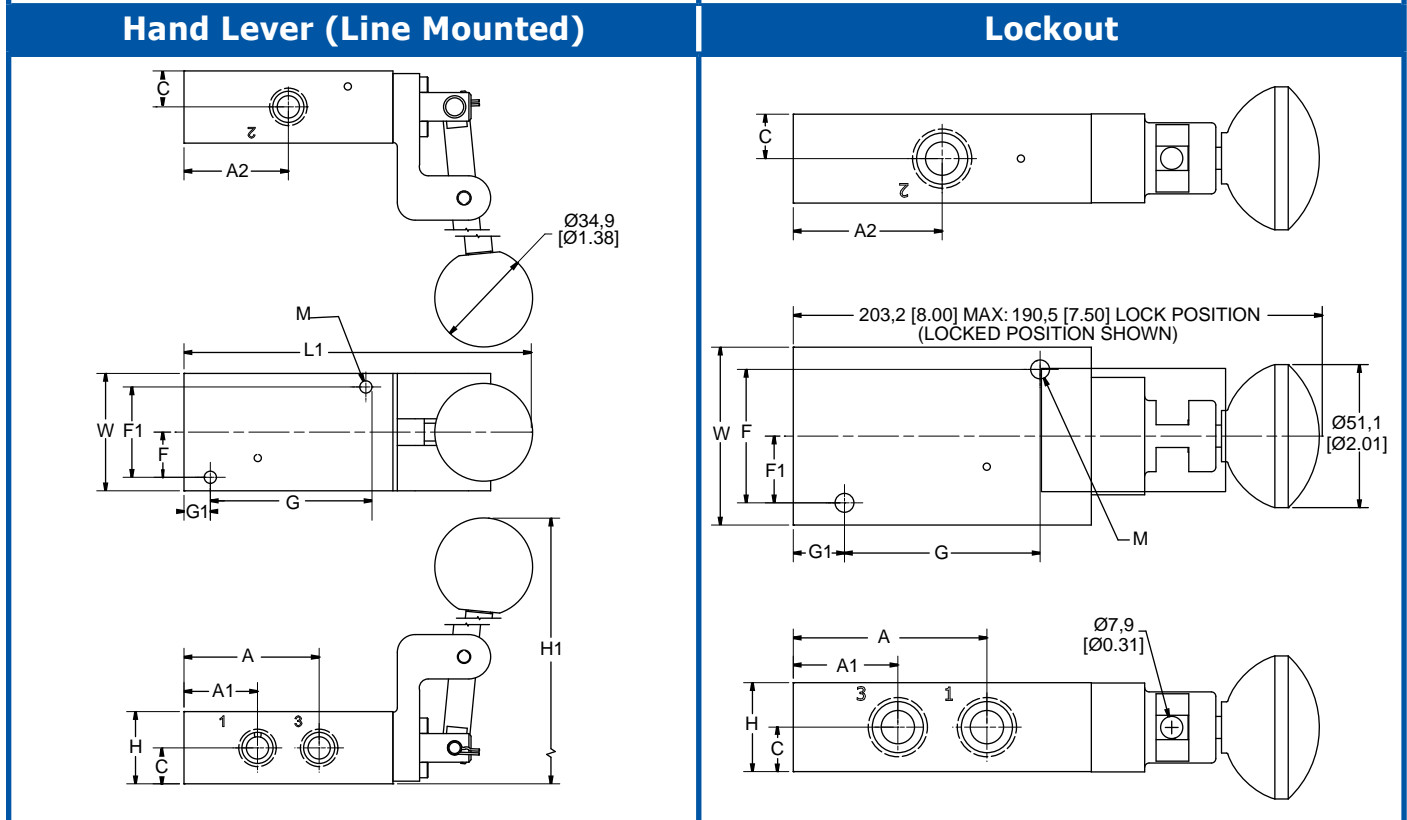
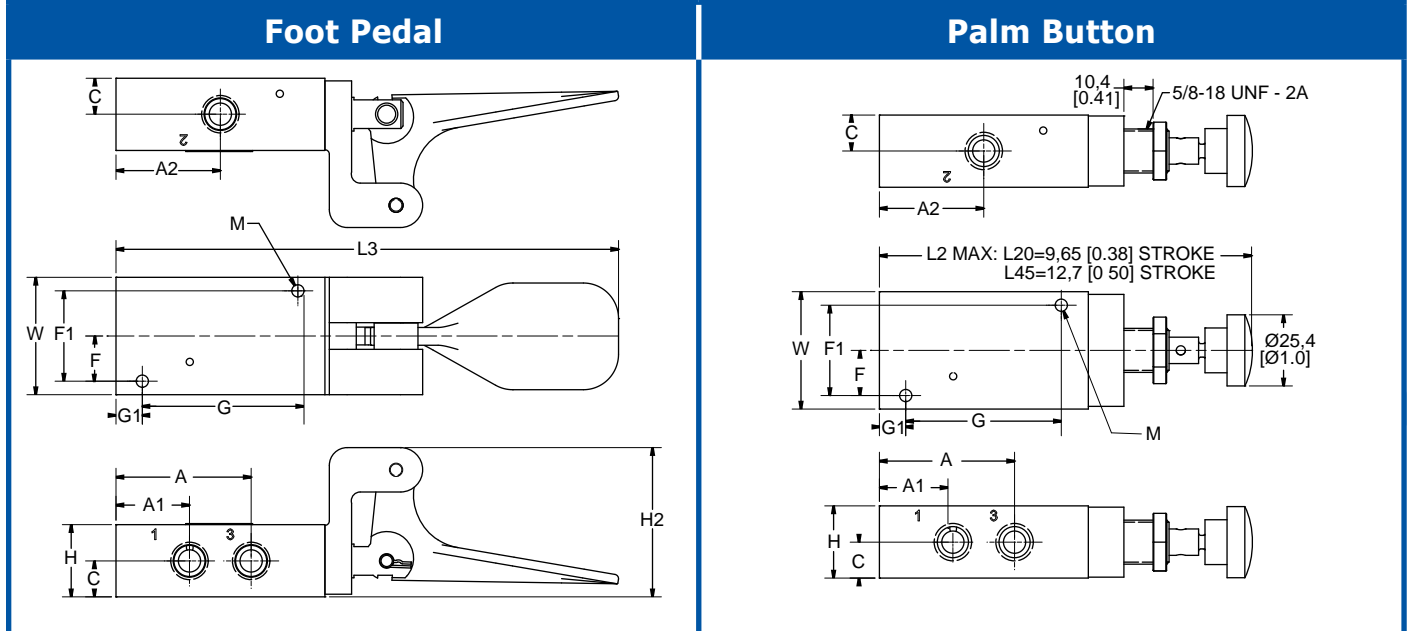

Series	A	A1	A2	C	F	F1	G	G1	H	H1	H2	L1	L2	L3	M	W
L20	48,2 1.90	26,2 1.03	37,3 1.47	12,7 0.50	16,1 0.64	32,3 1.27	55,6 2.19	9,7 0.38	25,4 1.00	136 5.35	53,3 2.10	129 5.09	131 5.15	182 7.16	4,3 0.17	41,9 1.65
L45	69,1 2.72	39,3 1.47	53,1 2.09	16,0 0.63	23,9 0.94	47,8 1.88	69,8 2.75	18,3 0.72	31,8 1.25	88,9 3.50	56,3 2.22	168 6.62	171 6.75	214 8.42	6,6 0.26	63,5 2.50

Units of Measure: Top - mm, Bottom - inches

3/2



3 Way Compact Spool Valves Top Mount & Manifold

L21 Single

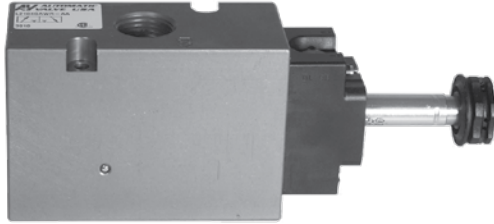

L2104GAWR-AA

L21 Double

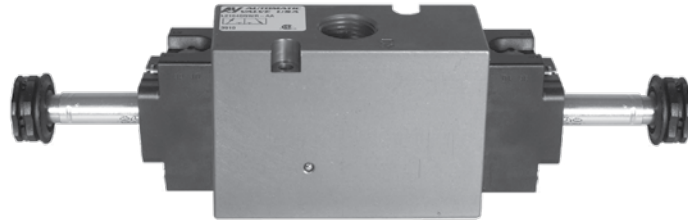

L2104GBWR-AA

B

Model Numbers

Series	Operator	Port Size	Flow l/min (Cv)	3 Way Normally Closed		3 Way Normally Open		Mat'l		Wt Kg (lb)
				Single	Double	Single	Double	Body	Seal	
L21	Weather-Proof and Explosion-Proof	1/4	1770 (1.8)					Aluminum	NBR	0,4 (0.9)
		3/8								
	Intrinsically-Safe ¹	1/4								0,5 (1.2)
		3/8								

** = Coil Voltage Code. Coils also sold separately. Refer to "Electrical Information" at the end of this Section for additional information.

¹ Intrinsically-Safe coils can not be used on manifolds

Manifold

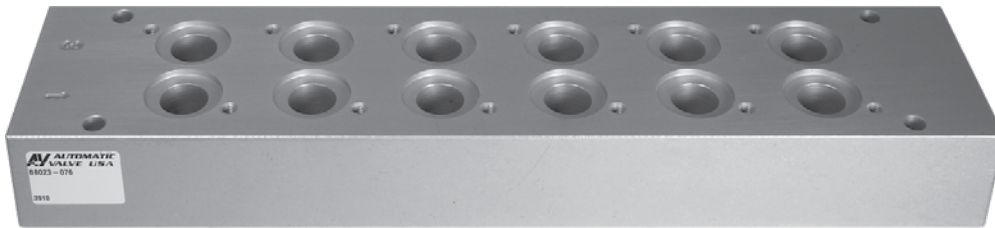

B8023-076

Model Numbers

Series	Manifold ²				Accessories	
	No. of Stations	Model Number	Ports 3, 1 & 5	Weight kg (lb)	Blocking Disk	Blank Station Cover
L21	2	B8023-072	3/8	0,45 (1.0)	A8020-202	L21-006
	4	B8023-074		0,82 (1.8)		
	6	B8023-076		1,0 (2.2)		
	8	B8023-078		1,1 (2.5)		
	10	B8023-080		1,3 (2.8)		

² Seals and Mounting Hardware included.



Dimensional Information

L21

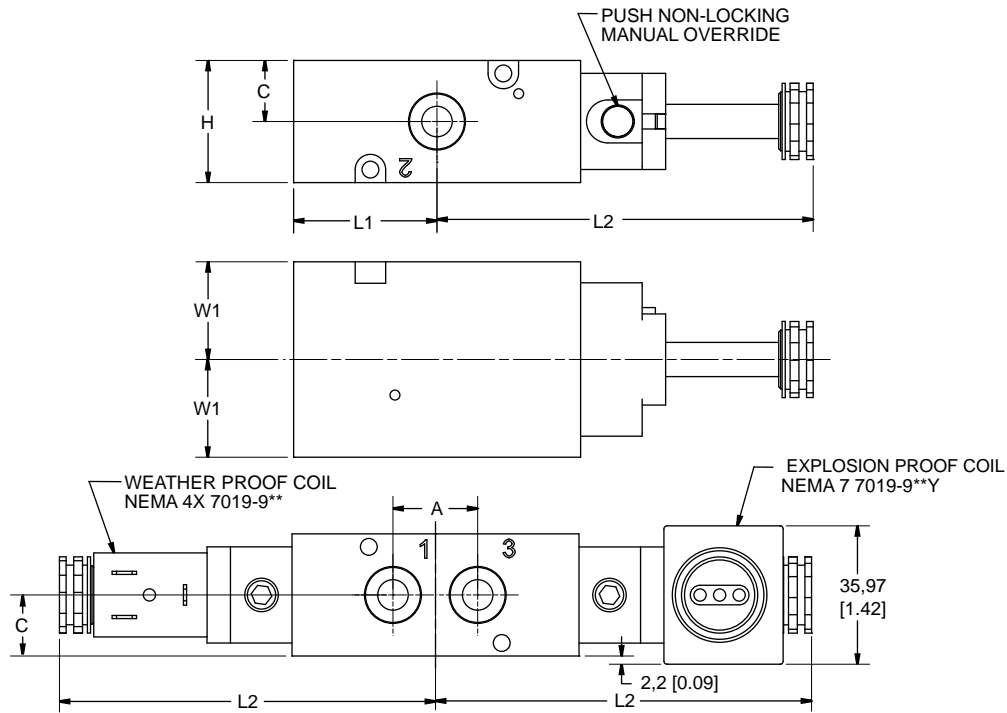

Series	A	C	H	L1	L2	W1
L21	22,02 0.87	15,88 0.63	31,75 1.25	37,26 1.47	97,79 3.85	25,4 1.00

Units of Measure: Top - mm, Bottom - inches

Manifold

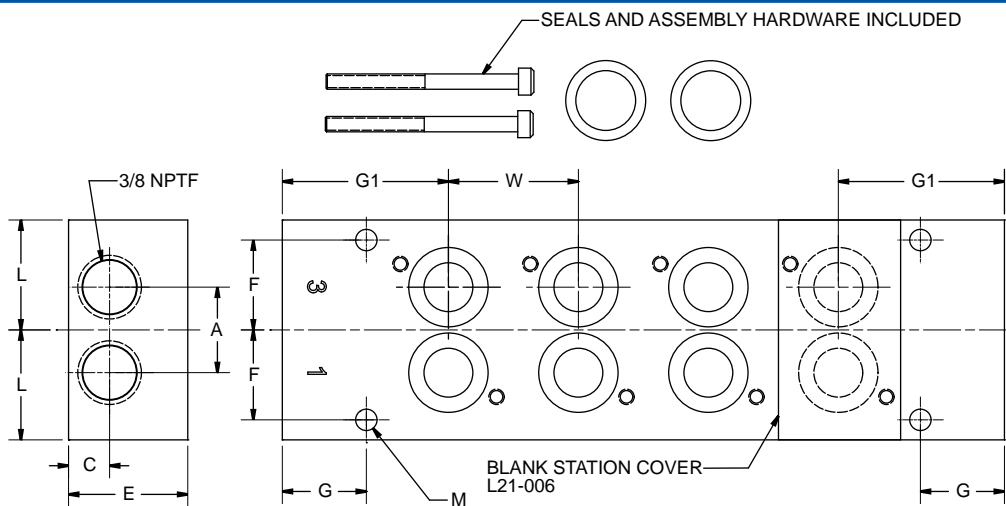

Series	A	C	E	F	G	G1	L	M	W
L21	22,23 0.88	10,67 0.42	30,99 1.22	23,37 0.92	21,84 0.86	43,18 1.70	28,58 1.13	5,56 0.22	33,78 1.33

Units of Measure: Top - mm, Bottom - inches

3/2



3 Way Compact Spool Valves Configuration Example

Valve With W-Solenoid Cap + Coil = Valve With Coil



L2003GAWR

+



NEMA 4x with DIN
43650 Form B
Connection
7019-9**

=

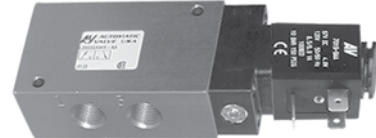

L2003GAWR-**

B



L2003GAWR

+



NEMA 4x with
18" Leads
7019-9**G

=



L2003GAWR-**G



L2003GAWR

+



NEMA 4x 1/2" Conduit
with 30" Leads
7019-9**C

=



L2003GAWR-**C



L2003GAWR

+



Explosion-Proof 1/2"
Conduit with 24" Leads

=

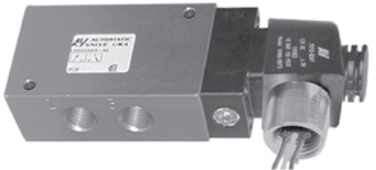

L2003GAWR-**Y



L2003GAWR

+



ATEX Explosion-Proof
with 39" Cable

=

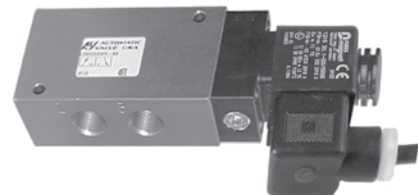

L2003GAWR-**Z

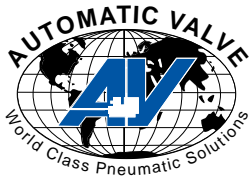

3 Way Compact Spool Valves

Electrical Information

3/2



3 Way Compact Spool Valves

B

Part Numbers

Description	Operator Type	Instructions	Wt. Kg(lb)	Coil Part Number **=Voltage
Weather-Proof DIN 43650 Industrial Form B Connection NEMA 4X	W	Order coil separately (specify voltage code from below)	0,05 (0.12)	7019-9**
Weather-Proof 18" Leads NEMA 4X	W	Order coil separately (specify voltage code from below)	0,05 (0.12)	7019-9**G
Weather-Proof 1/2" Conduit with 30" Leads NEMA 4X	W	Order coil separately (specify voltage code from below)	0,05 (0.12)	7019-9**C 7019-9**CT (high temp 82°C max)
Explosion-Proof 1/2" Conduit with 24" Leads CSA & FM Approved CL. I; Zone1 ExmII T4; AExmII CL. I; Div.1; GR. A, B, C, D CL. II; GR. E, F, G CL. III T4 Ta=-20°C to +60°C NEMA 4, 4X, 7C, 7D, 9	W	Order coil separately (specify voltage code from below)	0,20 (0.44)	7019-9**Y
Intrinsically-Safe Strain Relief Ex ia CL. I; GR. A, B, C, D CL. II; GR. E, F, G CL. III; Div.1; T5	V	Coil and Connector included with valve (24VDC only)	0,21 (0.46)	A7106-374-DB
A7106-374 Must be Used with an Intrinsically-Safe Barrier For more information refer to "Intrinsic Safety" insert on Page D7.				
Explosion-Proof 3m Cable & Strain Relief Ex m II T5 PTB 03 ATEX2018 X Ex II 2 G EEx m II T5 Ex II 2 D IP65 T95°C	Z	Order coil separately (specify voltage code from below)	0,36 (0.78)	7152-9**

Voltage Codes (Lower wattage options available, consult factory)

** Code	Voltage +/- 10%		Current (Amps)								Resistance (OHMS @ 25°C)				Power (AC=VA, DC=Watts)			
	Operator Type: NEMA 4 NEMA 7,9 & ATEX		Inrush				Holding				W		V		W		V	
			W		Z		W		Z		W		V		W		V	
			NEMA		ATEX		NEMA		ATEX		NEMA		ATEX		NEMA		ATEX	
		4, 4x	7, 9	Exia	Exm	4, 4x	7, 9	Exia	Exm	4, 4x	7, 9	Exia	Exm	4, 4x	7, 9	Exia	Exm	
DA	24/50 24/60	-	.36	-	-	-	.24	-	-	-	32	-	-	-	6.9	-	-	-
AA	120/50 120/60	120/60	.08	.10	-	.04	.05	.05	-	.03	840	530	-	1664	6.9	6.5	-	3.4
AB	230/50 230/60	240/60	.04	.05	-	.02	.03	.03	-	.01	3310	2345	-	6730	6.4	6.8	-	3.3
DA	12 VDC	12VDC	.38	.38	-	.27	.38	.38	-	.27	32	32	-	45	4.8	4.5	-	3.5
DB	24 VDC	24VDC	.20	.19	.05	.14	.20	.19	.05	.14	121	128	275	177	4.8	4.5	1.6	3.5
AB	125 VDC	-	.04	-	-	-	.04	-	-	-	3310	-	-	-	5.9	-	-	-

Connectors (Not polarity dependent)

DIN 43650 Industrial Form B	Maximum Cable Diameter: 9mm (0.35")		Strain Relief with Light		1/2" Conduit without Cord	Molded with 6' Cord	Strain Relief with Light & 6' Cord	
Type	Strain Relief without Cord	100-240 AC 48-120 DC	6-48 AC/DC	100-240 AC 48-120 DC	6-48 AC/DC	100-240 AC 48-120 DC	6-48 AC/DC	
Part Number	7020-001	7020-AA	7020-DB	7039-001	7020-006	7094-006	7094-007	

3/2



3 Way Compact Spool Valves Options



Options (Add the Suffix to the end of the Model Number in alpha-numeric order)

Suffix	Option	Description
A	Fluoroelastomer Seals	For applications where fluid media or ambient conditions are not compatible with nitrile seals. (Lockout Valve only) <i>Note: Fluorocarbon seals do not increase the effective temperature range of the valve. For high temperature applications, consult the factory.</i>
B	External Pilot	For solenoid applications where the pressure to port one is less than 2 BAR (35 PSIG). See example below for field conversion.
		<p style="text-align: center;">Field Conversion</p> <ul style="list-style-type: none"> Remove solenoid and cap from the valve body. Rotate the gasket 180° so that the internal pilot hole in the valve body is covered by the gasket. Refasten the gasket, cap and solenoid to the valve body. Make sure the gasket completely covers the internal pilot hole before tightening the M3 screws. Torque to 1,02 N-m (9 in-lbs) ±10%. Remove the 1/8 NPTF pipe plug from the cap and make the external pilot connection.
C	Conduit Coil	Refer to the "Electrical Information" page in this section for details.
CT	Conduit Coil High Temperature	Refer to the "Electrical Information" page in this section for details.
D	Dustproof	For applications in extremely dusty and contaminated environments. Vent ports are plugged and spring pad breather vent is eliminated.
G	Coil With 18" Leads	Refer to the "Electrical Information" page in this section for details.
L	Low Watt Coil	Power Consumption = 2.5 Watts. Standard as Push Non-Locking Override. Also available with Option 2, Extended Turn-Locking Override.
LL	Lowest Watt Coil	Power Consumption = 0.7 Watts. Standard as Extended Turn-Locking Override.
W	G Threads	All ports tapped to metric "G" standard.
Y	Explosion-Proof Coil (CSA, FM)	Refer to the "Electrical Information" page in this section for details.
Z	Explosion-Proof Coil (Atex, PTB)	Refer to the "Electrical Information" page in this section for details.
1	Push Turn-Locking Override	Solenoid cap provides an override that is pushed in and turned to actuate & lock in the "on" position.
2	Extended Turn-Locking Override	Solenoid cap provides an extended override that is turned to lock in the "on" position.
4	No Override	Solenoid cap does not provide a manual override.

AV AUTOMATIC VALVE

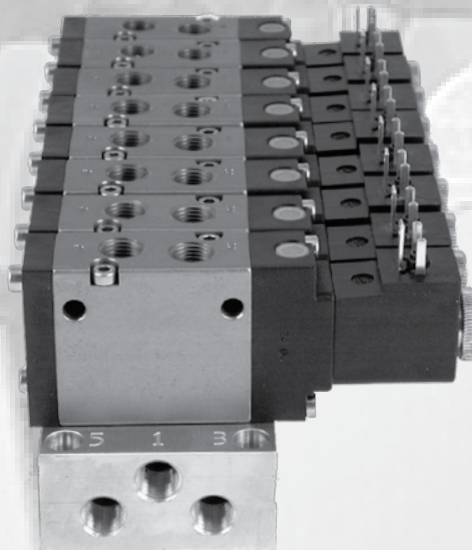
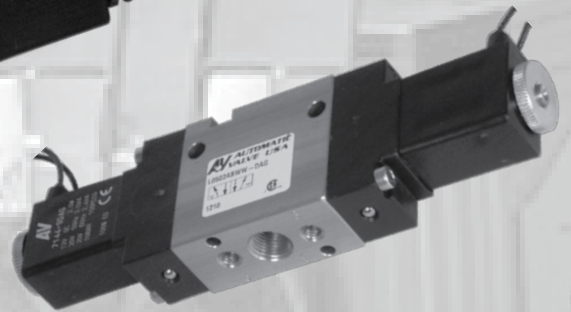
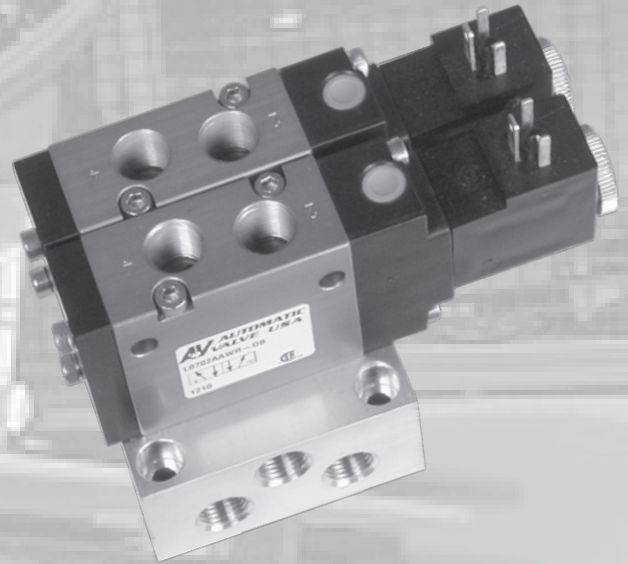
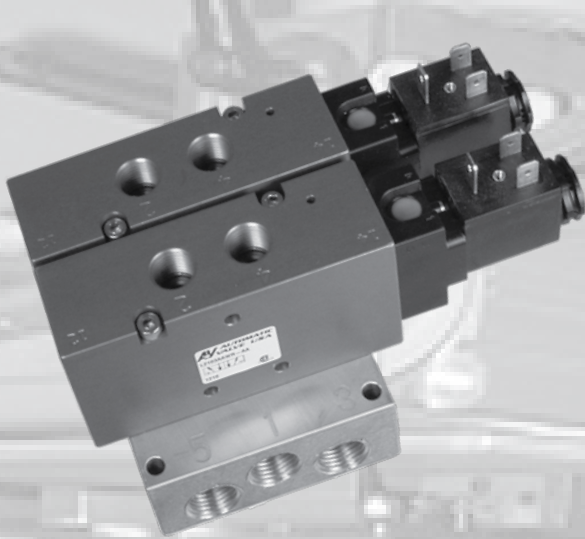

Top Mount Spool Valves

	Page
Design Features	C2
Specifications	C3
Model Numbers	C3
Weather-Proof & Explosion-Proof	C4-C5
Air Pilot	C6-C7
Manual	C8-C10
Manifolds	C11-C12
Options	C13
Configuration Example	C14
Electrical Information	C15
Service Information	C16

5/2



5/3

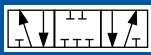

Top Mount Spool Valves Design Features

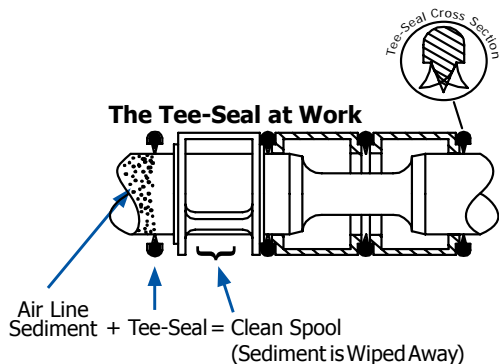
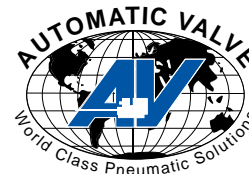

Valves

- Balanced spool construction allows ports to be plugged for 2 or 3 way function, or restricted for inexpensive cylinder exhaust speed control. For selector or dual pressure applications, consult the Factory.
- Manifold or line mount: flexible, efficient.
- Solid manifold construction for rugged, reliable performance.
- Specific application needs? Consult the factory. We will build it for you.

C



Tapered Tee-Seal Eats Dirt

- Bidirectional tapered Tee-Seal eliminates sticking problems.
 - Flexes to clean spool
 - Mechanically Locked
 - No Spiral Twist
 - No Extrusion
 - Air Line Sediment is Wiped Away.
- Tested tough and proven reliable according to SAE specifications: Rust and water injected every 864,000 cycles for 20 million cycles.



Solenoid ... Guaranteed Against Burnout

- Three-way pilot uses full air line pressure to shift the valve.
- Pilot is internally supplied when the pressure at port one is 35 to 150 PSIG (240 to 1030 kPa).
- Coil is hermetically sealed as an integral watertight molded unit.
- Intrinsically-safe and explosion-proof versions available.
- Push Non-Locking Override is standard. (Extended Turn and Turn-Locking available)



Products Certified To:

- CSA - (C22.2 and UL STD 429)
- Factory Mutual - Explosion Proof Environments
- ATEX - Explosion Proof Environments
- CE - EMF and Low Voltage Directives



Top Mount Spool Valves Specs & Model Numbers



Specifications

Valve Operation		Valve Operation	
Operating Temperatures 	Solenoid Pilot Operated	Treated Buna-N Seals (Treated NBR, Standard)	Fluoroelastomer Seals (FPM (FKM), Standard - L05; Option A on L21 & L45)
	Standard	-18°C to +50°C (0°F to +123°F)	-18°C to +50°C (0°F to +123°F)
	High Temp Coil (Option CT)	-18°C to +82°C (0°F to +180°F)	-18°C to +82°C (0°F to +180°F)
Operating Pressures 	Solenoid Pilot Operated	Inlet Port	External Pilot Port
	Standard 2 Position	L05: 345 - 1030 kPa (50 - 150 PSIG) L21 & L45: 240 - 1030 kPa (35 - 150 PSIG) * L45 requires a min 1/2" ID inlet	-
	Standard 3 Position	345 - 1030 kPa (50 - 150PSIG)	-
	External Pilot (Option B)	Vacuum -240 kPa (Vacuum -35 PSIG)	240 - 1030 kPa (35 - 150 PSIG)
Filtration & Lubrication 	Media - Air Or Inert Gas		
Air Line Lubrication of Automatic Valve products is not required, but is recommended to maximize service life. Oils should be compatible with seal material, have an ISO 32 viscosity, and have an aniline range between 82°C (180°F) and 99°C (210°F). Filter to 50 microns or better. For temperatures below 40°F, air must be dry to prevent formation of ice. Refer to the Maintenance section of this catalog for recommended lubricants.			

Model Numbers

Series	Body Type	Port Size	Function	Body Design	Operator 1	Center Operator	Operator 2	Voltage ³	Options*
L05	0 Inline, Manifold	2 1/8	A 4 Way 2 Position	A Single	A Air Pilot	N/A	A Air Pilot	-AA 110/50, 120/60	B External Pilot Connection
				B Double	I Palm Button		R 2 Pos'n Spring	-AB 220/50, 240/60, 125VDC	
L07	1 Manifold	2 1/8, 3 1/4	A 4 Way 2 Position		A Air Pilot	D 3 Pos'n Spring	A Air Pilot	-DA 22/50, 24/60, 12VDC	A Fluoroelastomer Seals
L21	0 Inline, Manifold	3 1/4	B 4 Way 2 Position ¹		F Hand Lever - Line	C 3 Position Spring Manual	-DB 24VDC	B External Pilot Connection	
			C 4 Way 3 Position Block		G Hand Lever - Manifold	M 2 Position Detent Manual	C Conduit Coil		
			D 4 Way 3 Position Exhaust		I Palm Button	N 3 Position Detent Manual	CT Conduit Coil High Temp		
L45	0 Inline, Manifold	5 1/2	E 4 Way 3 Position Pressure		J Cam	R 2 Position Spring	D Dustproof		
				K Foot Pedal	V Intrinsically-Safe Solenoid ² (24VDC only)	G 18" Flying Leads			
				L Foot Treadle	W Weather-Proof Solenoid	L Low Watt Coil (2.5 Watts)	LL Lowest Watt Coil (0.7 Watts)	S 303 Stainless Steel Body (L45 only)	
						SS 316 Stainless Steel Body (L45 only)	W G (BSPP)Threads	Y Explosion-Proof Coil (CSA,FM)	
							Z Explosion-Proof Coil (ATEX)	1 Push Turn-Locking Override	
								2 Extended Turn-Locking Override	
								4 No Override	

* Not all Options are available for all models. Refer to "Options" at the end of this Section for additional information.

¹ Use varies. Consult the Factory for details. ² Can not be used on a manifold. ³ Consult the Factory for additional voltages.

5/2



5/3

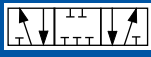

Top Mount Spool Valves

Weather-Proof & Explosion-Proof

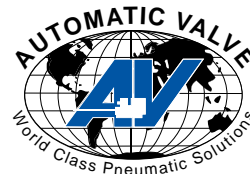

Single



L0502AAWR



L0712AAWR
(manifold mounted only)



L2103AAWR



L4505AAWR

Double



L0502ABWW



L0712DBWW
(manifold mounted only)



L2103ABWW



L4505ABWW

Model Numbers

Series	Port Size	Flow l/min (Cv)		5/2		5/3			Mat'l		Wt Kg (lb)
		5/2	5/3	Single	Double	Block	Exhaust	Pressure	Body	Seal	
L05	1/8	390 (0.4)	-	L0502AAWR-**	L0502ABWW-**	-	-	-	FPM (FKM)	0,2 (0.4)	
L07	1/8	690 (0.7)	538 (0.5)	L0712AAWR-**	L0712ABWW-**	L0712CBWDW-**	L0712DBWDW-**	L0712EBWDW-**	Aluminum	NBR	0,3 (0.6)
	1/4			L0713AAWR-**	L0713ABWW-**	L0713CBWDW-**	L0713DBWDW-**	L0713EBWDW-**			
L21	1/4	1770 (1.8)	1381 (1.4)	L2103AAWR-**	L2103ABWW-**	L2103CBWDW-**	L2103DBWDW-**	L2103EBWDW-**			
L45	1/2	4755 (4.8)	3709 (3.7)	L4505AAWR-**	L4505ABWW-**	L4505CBWDW-**	L4505DBWDW-**	L4505EBWDW-**	0,7 (1.6)		

** = Coil Voltage Code. Coils also sold separately. Refer to "Electrical Information" at the end of this Section for additional information.

Dimensional Information

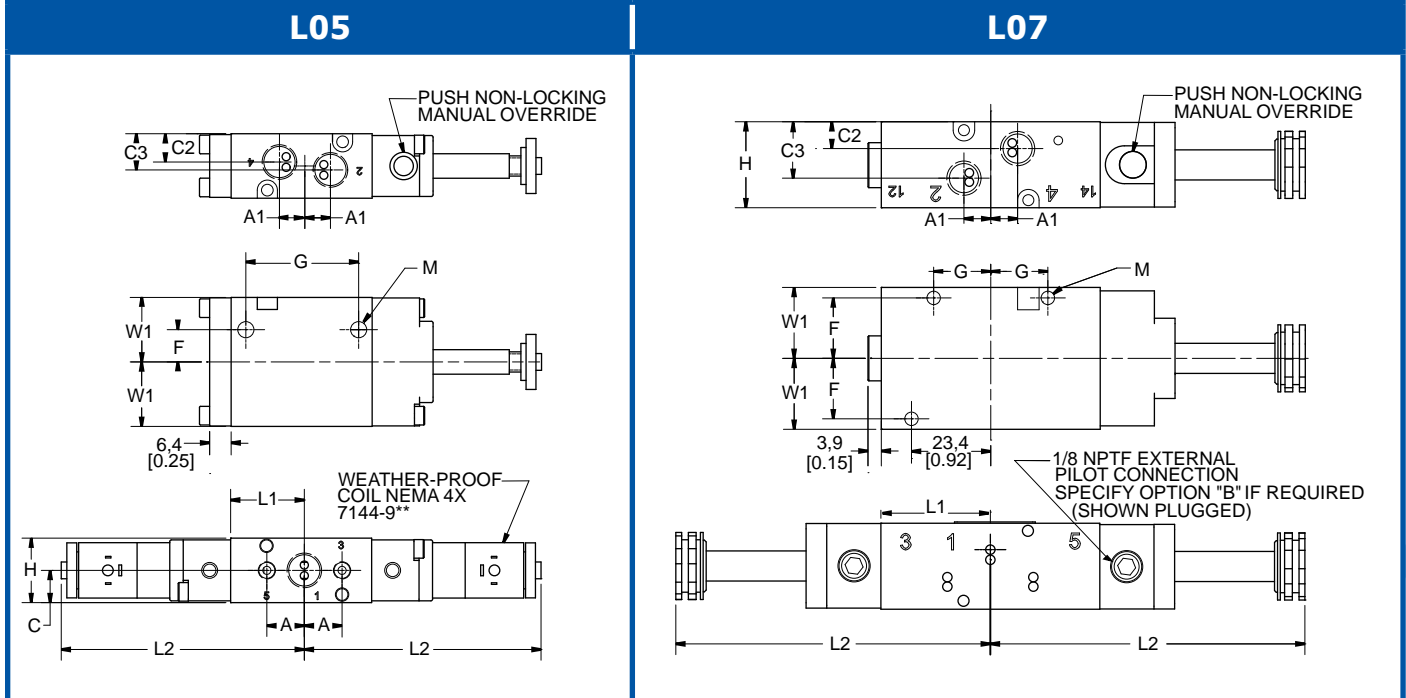

L21 & L45

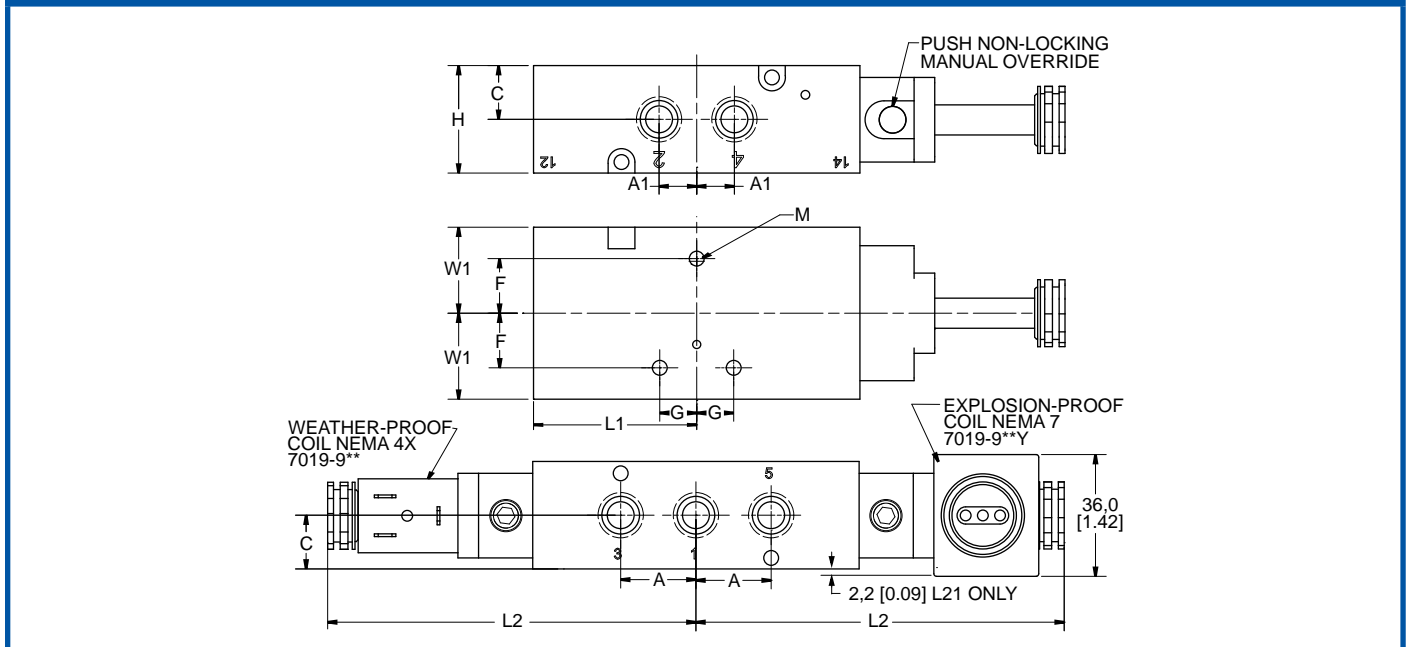

Series	A	A1	C	C2	C3	F	G	H	L1	L2	M	W1
L05	11,1 0.44	7,3 0.29	9,6 0.38	8,3 0.38	10,6 0.42	9,6 0.38	33,2 1.31	19,1 0.75	21,3 0.84	69,0 2.72	4,5 0.18	19,1 0.75
L07	-	7,9 0.31	-	7,9 0.31	16,9 0.66	16,1 0.64	10,9 0.43	25,4 1.0	32,3 1.27	92,7 3.65	4,4 0.17	24,6 0.97
L21	22,2 0.88	11,1 0.44	16,5 0.65	-	-	16,1 0.64	10,9 0.43	31,7 1.25	48,2 1.90	109 4.28	4,4 0.17	24,4 1.00
L45	34,5 1.36	34,5 1.36	21,0 0.83	-	-	19,0 0.75	17,0 0.68	42,2 1.66	69,0 2.72	129 5.07	6,7 0.27	31,8 1.25

Units of Measure: Top - mm, Bottom - inches

5/2



5/3

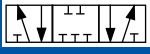

Top Mount Spool Valves

Air Pilot



Single



L0502AAAR



L0712AAAR
(manifold mounted only)



L2103AAAR



L4505AAAR

Double



L0502ABAA



L0713ABAA
(manifold mounted only)



L2103ABAA



L4505ABAA

Model Numbers

Series	Port Size	Flow l/min (Cv)		5/2		5/3			Material		Wt Kg (lb)
		5/2	5/3	Single	Double	Block	Exhaust	Pressure	Body	Seal	
L05	1/8	390 (0.4)	304 (0.3)	L0502AAAR	L0502ABAA	-	-	-	Aluminum	FPM (FKM)	0,2 (0.4)
L07	1/8	690 (0.7)	538 (0.5)	L0712AAAR	L0712ABAA	L0712CBADA	L0712DBADA	L0712EBADA		NBR	0,3 (0.6)
	1/4			L0713AAAR	L0713ABAA	L0713CBADA	L0713DBADA	L0713EBADA			
L21	1/4	1770 (1.8)	1381 (1.4)	L2103AAAR	L2103ABAA	L2103CBADA	L2103DBADA	L2103EBADA		0,5 (1.1)	
L45	1/2	4755 (4.8)	3709 (3.7)	L4505AAAR	L4505ABAA	L4505CBADA	L4505DBADA	L4505EBADA	0,8 (1.7)		

Dimensional Information

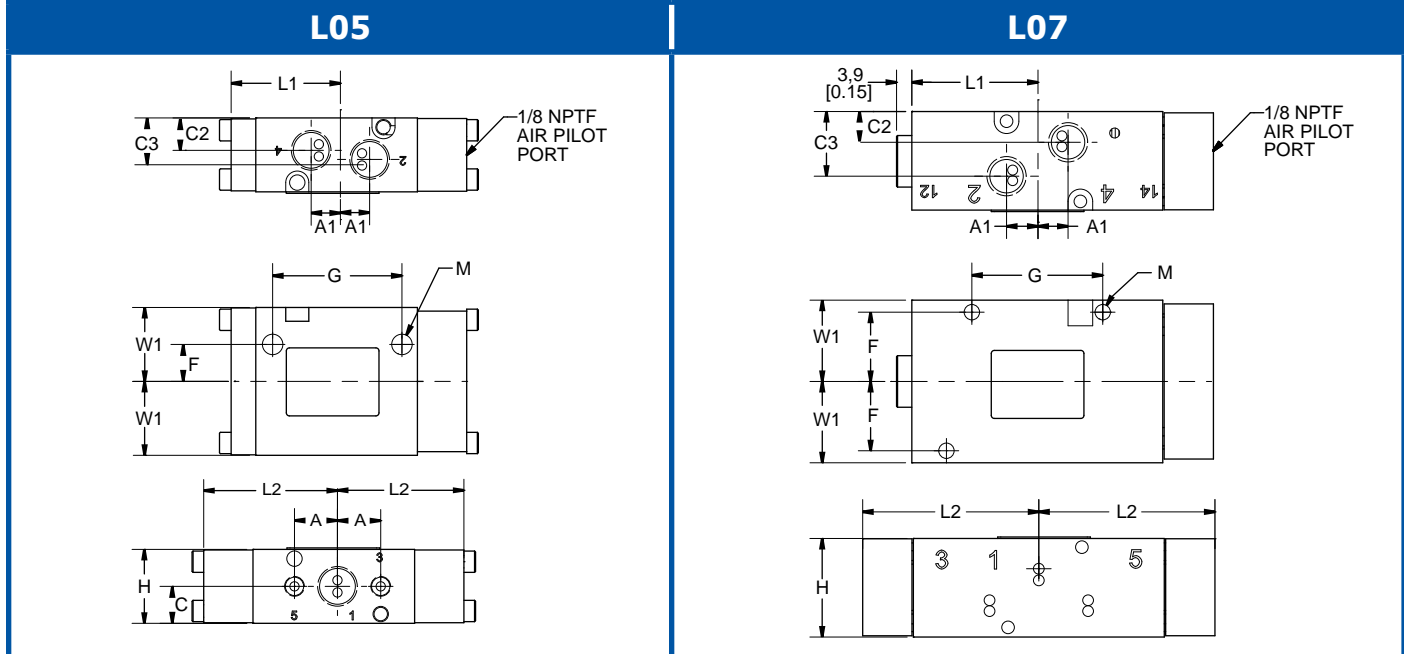

L21 & L45

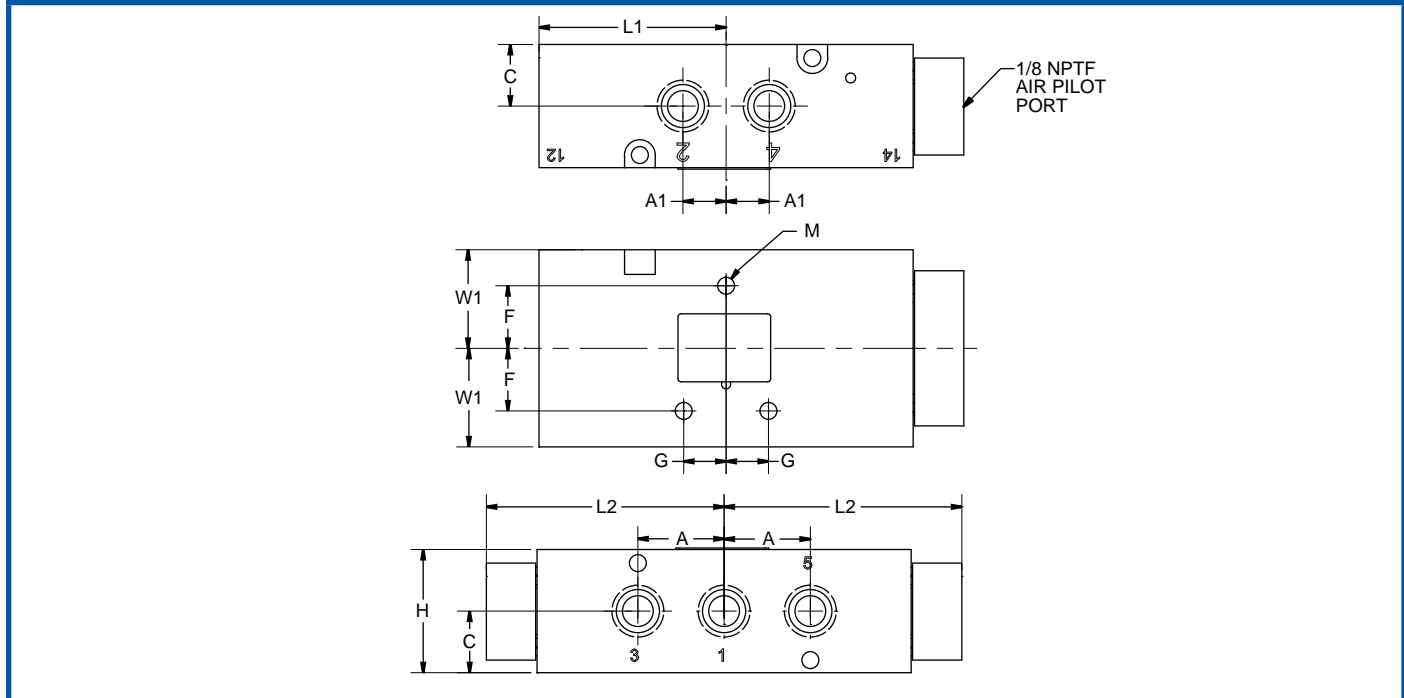

Series	A	A1	C	C2	C3	F	G	H	L1	L2	M	W1
L05	11,1 0.44	7,3 0.29	9,6 0.38	8,3 0.38	10,6 0.42	9,6 0.38	33,2 1.31	19,1 0.75	28,2 1.11	34,5 1.36	4,5 0.18	19,1 0.75
L07	-	7,9 0.31	-	7,9 0.31	16,9 0.66	18,3 0.72	33,5 1.32	25,4 1.00	32,3 1.27	45,0 1.77	4,0 0.16	21,0 0.83
L21	22,2 0.88	11,1 0.44	16,5 0.65	-	-	16,1 0.64	10,9 0.43	31,7 1.25	48,2 1.90	61,0 2.40	4,4 0.17	24,4 1.00
L45	34,5 1.36	17,3 0.68	21,0 0.83	-	-	19,0 0.75	17,3 0.68	42,2 1.66	69,0 2.72	88,9 3.50	6,7 0.27	31,8 1.25

Units of Measure: Top - mm, Bottom - inches

5/2



Top Mount Spool Valves Manual



5/2 Palm Button



L0502AAIR



L2103BAIM



L4505BAIR

5/2 Hand Lever - Line Mounted



L2103BAFM



L4505BAFM

5/2 Hand Lever - Manifold Mounted



L0712BAGM

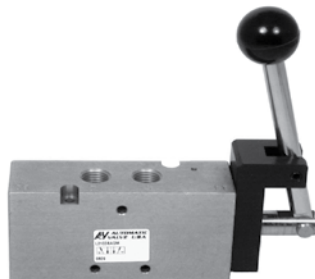

L2103BAGM



L4505BAGM

Model Numbers

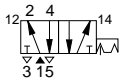
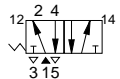
Series	Port Size	Flow (5/2) l/min (Cv)	Operator	5/2 (4 Way 2 Position)		Material		Wt kg (lb)	
				Detented	Spring Return	Body	Seal		
									
L05	1/8	390 (0.4)	Palm Button	-	L0502AAIR	Aluminum	FPM (FKM)	12 (0.4)	
L07	1/8	690 (0.7)	Hand Lever Manifold Mounted	L0712BAGM	L0712AAGR		NBR		0,3 (0.6)
	1/4			L0713BAGM	L0713AAGR				
L21	1/4	1770 (1.8)	Hand Lever Line Mounted	L2103BAFM	L2103AAFR				0,5 (1.1)
			Hand Lever Manifold Mounted	L2103BAGM	L2103AAGR				
			Palm Button	L2103BAIM	L2103AAIR				
L45	1/2	4755 (4.8)	Hand Lever Line Mounted	L4505BAFM	L4505BAFR				0,96 (2.1)
			Hand Lever Manifold Mounted	L4505BAGM	L4505BAGR				
			Palm Button	L4505BAIM	L4505BAIR				

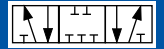

5/3 Hand Lever - Line Mounted



5/3 Palm Button



5/3 Hand Lever - Manifold Mounted



Model Numbers

Series	Port Size	Flow (5/3) l/min (Cv)	Operator	5/3 (4 Way 3 Position)						Body Material	Seal Material	Weight kg (lb)
				Detented			Spring Center					
				Block	Exhaust	Pressure	Block	Exhaust	Pressure			
L07	1/8	538 (0.5)	Hand Lever Manifold Mounted							Aluminum	NBR	0,3 (0.6)
	1/4			L0712CAGN	L0712DAGN	L0712EAGN	L0712CBGC	L0712DBGC	L0712EBGC			
L21	1/4	1381 (1.4)	Hand Lever Line Mounted	L2103CAFN	L2103DAFN	L2103EAFN	L2103CBFC	L2103DBFC	L2103EBFC			0,5 (1.1)
			Hand Lever Manifold Mounted	L2103CAGN	L2103DAGN	L2103EAGN	L2103CBGC	L2103DBGC	L2103EBGC			
			Palm Button	L2103CAIN	L2103DAIN	L2103EAIN	L2103CBIC	L2103DBIC	L2103EBIC			
L45	1/2	3709 (3.7)	Hand Lever Line Mounted	L4505CAFN	L4505DAFN	L4505EAFN	L4505CBFC	L4505DBFC	L4505EBFC			1,0 (2.1)
			Hand Lever Manifold Mounted	L4505CAGN	L4505DAGN	L4505EAGN	L4505CBGC	L4505DBGC	L4505EBGC			
			Palm Button	L4505CAIN	L4505DAIN	L4505EAIN	L4505CBIC	L4505DBIC	L4505EBIC			

5/2 

5/3 

Top Mount Spool Valves Manual

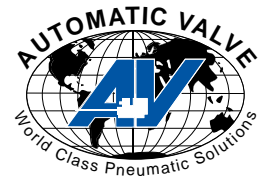

Dimensional Information

Hand Lever

Inline

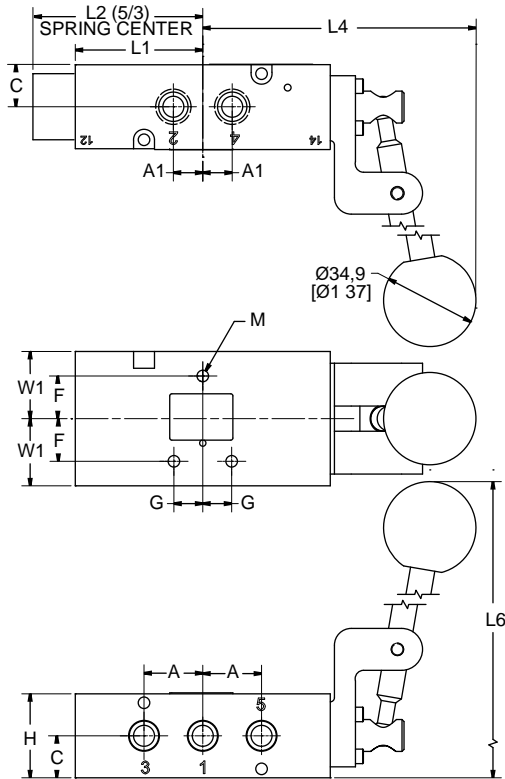

Manifold Mount

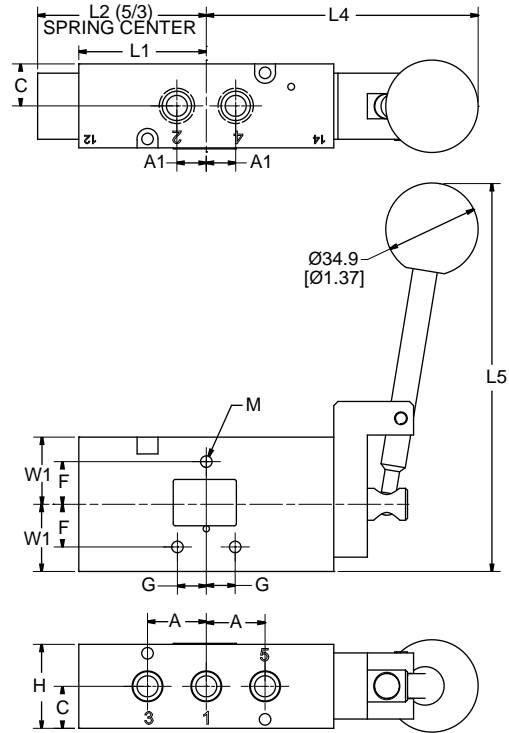

Palm Button

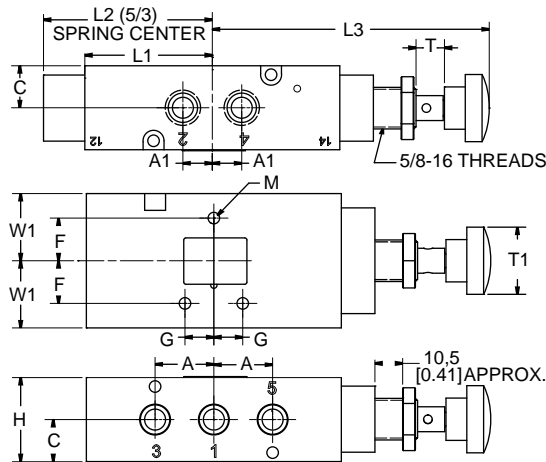

Series	A	A1	C	F	G	H	L1	L2	L3	L4	L5	L6	M	T	T1	W1
L05	11,1 0.44	7,3 0.29	9,6 0.38	9,6 0.38	33,2 1.31	19,1 0.75	28,2 1.11	-	42,2 1.66	-	-	-	4,5 0.18	4,8 0.19	16,0 0.63	19,1 0.75
L07		7,9 0.31	-	18,3 0.72	16,9 0.66	25,4 1.00	32,3 1.27	48,0 1.89	89,9 3.54	89,4 3.52	133 5.24	133 5.24	4,0 0.16	6,4 0.25	25,4 1.00	21,0 0.83
L21	22,2 0.88	11,1 0.44	16,0 0.63	16,1 0.64	10,9 0.43	31,7 1.25	48,2 1.90	64,0 2.52	106 4.16	105 4.14	137 5.39	138 5.41	4,4 0.17	9,5 0.38	25,4 1.00	25,4 1.00
L45	34,5 1.36	34,5 1.36	21,0 0.83	19,0 0.75	17,3 0.68	42,2 1.66	69,0 2.72	99,3 3.91	127 5.00	126 4.96	143 5.64	143 5.63	6,7 0.27	12,7 0.50	25,4 1.00	31,8 1.25

Units of Measure: Top - mm, Bottom - inches

Top Mount Spool Valves Manifolds

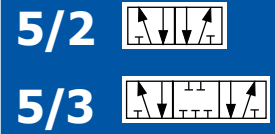

L05 Manifold

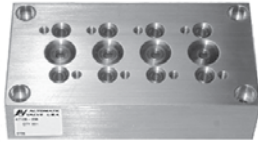

A7204-014

L21 Manifold

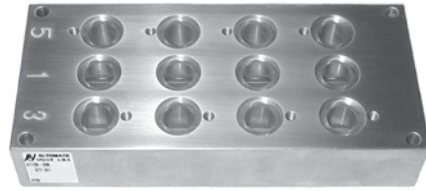

A8023-014

L07 Manifold

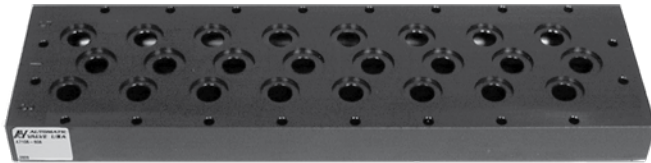

A7106-608

L45 Manifold



A7128-236

Features

- Common inlet and common exhaust ports.
- Valve cylinder ports face up.
- Mount through the valve, from the top.
- Seals and mounting hardware included.

Model Numbers

Series	Manifold				Accessories	
	Number of Stations	Model Number	Port 3, 1, & 5	Weight Kg (lb)	Blocking Disk	Blank Station Cover
L05	2	A7204-012	1/8	0,2 (0.5)	A7204-039	A7204-027
	4	A7204-014		0,3 (0.7)		
	6	A7204-016		0,4 (1.1)		
	8	A7204-018		0,6 (1.4)		
	10	A7204-010		0,7 (1.7)		
	12	A7204-112		0,9 (2.1)		
	14	A7204-114	1,1 (2.5)			
L07	2	A7106-602	1/4	0,2 (0.5)	A7105-202	A7106-603
	4	A7106-604		0,4 (0.8)		
	6	A7106-606		0,5 (1.1)		
	8	A7106-608		0,7 (1.4)		
	10	A7106-610		0,8 (1.8)		
	12	A7106-611		0,9 (2.1)		
L21	2	A8023-012	3/8	0,4 (0.9)	A8020-202	A8023-009
	4	A8023-014		0,9 (2.0)		
	6	A8023-016		1,3 (3.0)		
	8	A8023-018		1,8 (3.9)		
	10	A8023-010		2,2 (4.9)		
L45	2	A7128-232	3/4	1,1 (2.5)	-	A7128-229
	4	A7128-234		1,8 (4.0)		
	6	A7128-236		2,7 (5.9)		
	8	A7128-238		3,3 (7.8)		
	10	A7128-240		4,3 (9.6)		

Notes: Previous L45 manifolds (A7127-***) are not compatible with the current L45 valve.
Above manifolds are not compatible with bar stock L45 series valves. Consult the factory for further details.

5/2 

5/3 

Top Mount Spool Valves Manifolds

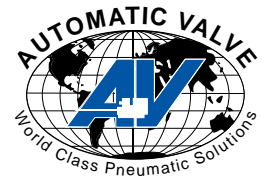

Dimensional Information

L05 Manifolds

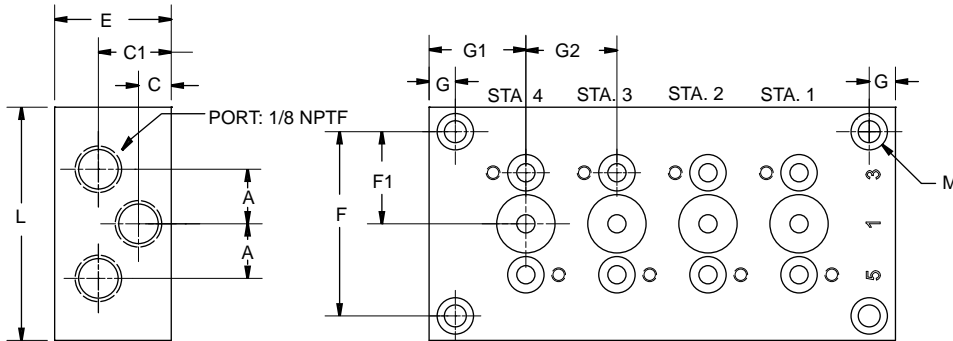

L07 Manifolds

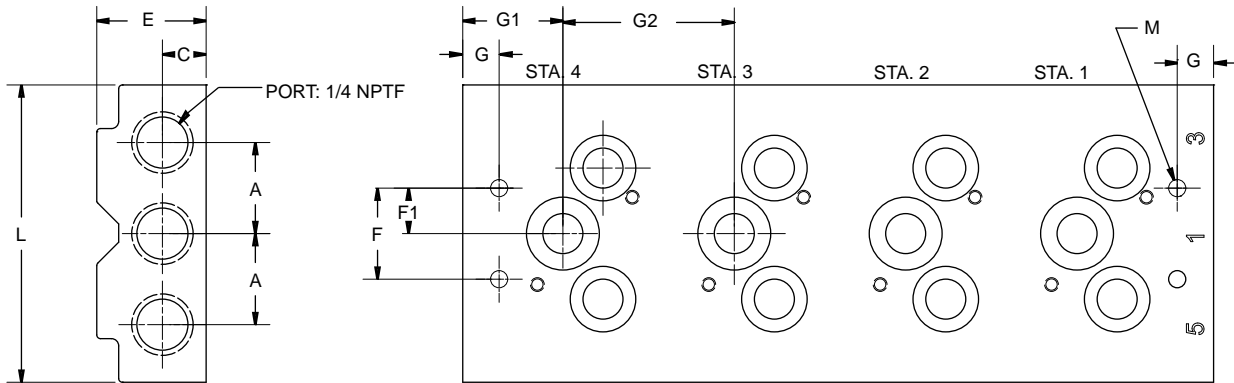

L21 & L45 Manifolds

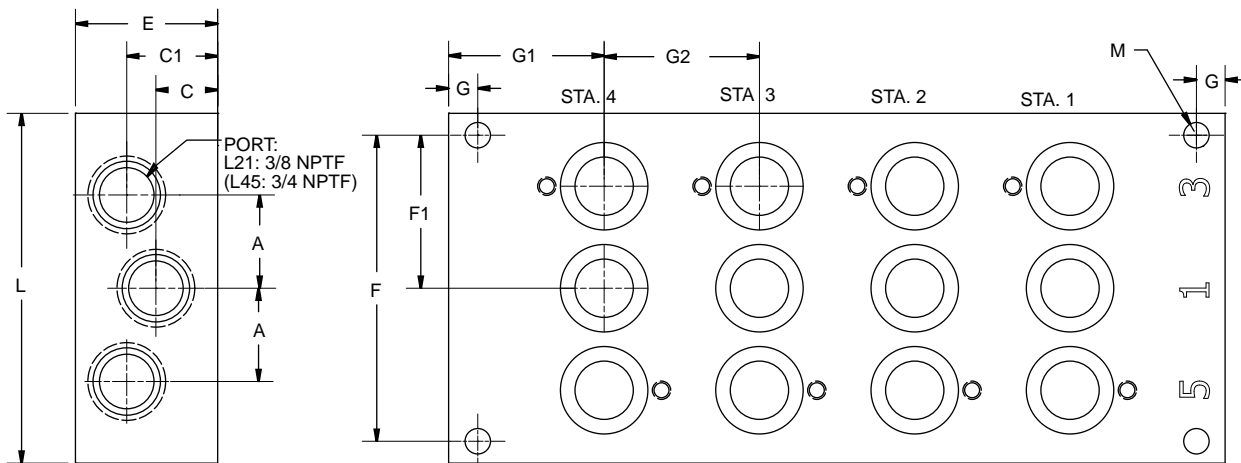

Series	A	C	C1	E	F	F1	G	G1	G2	L	M
L05	11,9 0.47	7,11 0.28	15,8 0.62	25,4 1.00	40,1 1.58	20,0 0.79	5,8 0.23	21,1 0.83	19,8 0.78	50,8 2.00	4,5 0.18
L07	12,2 0.78	9,6 0.38	-	23,9 0.94	12,2 0.78	9,91 0.38	7,87 0.31	21,8 0.86	37,3 1.47	64,8 2.55	3,81 0.15
L21	20,3 0.80	13,4 0.53	19,8 0.78	30,9 1.22	66,5 2.62	33,3 1.31	6,4 0.25	33,8 1.33	33,8 1.33	76,2 3.00	5,6 0.22
L45	40,1 1.58	19,3 0.76	30,0 1.18	50,8 2.00	38,1 1.50	19,1 0.75	13,9 0.55	43,4 1.71	43,4 1.71	117 4.60	8,6 0.34

Units of Measure: Top - mm, Bottom - inches

L05 Options (Add the suffix to the end of the model number in alpha-numeric order)

Suffix	Option	Description
B	External Pilot	For solenoid applications where the pressure to port one is less than 35 PSIG (2 BAR). If an externally piloted L05 is required, it must be ordered as such. Field conversion is not applicable.

L07, L21, L45 Options (Add the suffix to the end of the model number in alpha-numeric order)

Suffix	Option	Description
A	Fluoroelastomer Seals	For applications where fluid media or ambient conditions are not compatible with nitrile seals. <i>Note: Fluorocarbon seals do not increase the effective temperature range of the valve. For high temperature applications, consult the factory.</i>
B	External Pilot	For solenoid applications where the pressure to port one is less than 35 PSIG (2 BAR). See example below for field conversion of the L07, L21 and L45.
		<p style="text-align: center;">Field Conversion for the L07, L21 & L45</p> <ul style="list-style-type: none"> Remove solenoid and cap from the valve body. Rotate the gasket 180° so that the internal pilot hole in the valve body is covered by the gasket. Refasten the gasket, cap and solenoid to the valve body. Make sure the gasket completely covers the internal pilot hole before tightening the M3 screws. Torque to 1,02 N-m (9 in-lbs) ±10%. Remove the 1/8 NPTF pipe plug from the cap and make the external pilot connection.
C	Conduit Coil	Refer to the "Electrical Information" page in this section for details.
CT	Conduit Coil High Temperature	With 30" Leads. Refer to the "Electrical Information" page in this section for details .
D	Dustproof	For applications in extremely dusty and contaminated environments. Vent ports are plugged and spring pad breather vent is eliminated.
G	Coil With 18" Leads	Refer to the "Electrical Information" page in this section for details.
L	Low Watt Coil	Power Consumption = 2.5 Watts. Standard as Push Non-Locking Override. Also available with Option 2, Extended Turn-Locking Override.
LL	Lowest Watt Coil	Power Consumption = 0.7 Watts. Standard as Extended Turn-Locking Override.
S	303 Stainless Steel	303 Stainless Steel body, all other external parts are corrosion resistant; for corrosive environment applications (L45 only).
SS	316 Stainless Steel	316 Stainless Steel body, all other external parts are corrosion resistant; for corrosive environment applications (L45 only).
W	G Threads	All ports tapped to metric "G" standard.
Y	Explosion-Proof Coil (CSA, FM)	Refer to the "Electrical Information" page in this section for details.
Z	Explosion-Proof Coil (Atex, PTB)	Refer to the "Electrical Information" page in this section for details.
1	Push Turn-Locking Override	Solenoid cap provides an override that is pushed in and turned to actuate & lock in the "on" position.
2	Extended Turn-Locking Override	Solenoid cap provides an extended override that is turned to lock in the "on" position.
4	No Override	Solenoid cap does not provide a manual override.

5/2



5/3

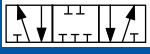

Top Mount Spool Valves Configuration Example

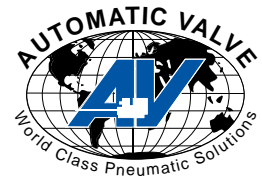

Valve With W-Solenoid Cap

+

Coil

=

Valve With Coil



L2103AAWR

+



7019-9**
(L05: 7144-9**(not shown))

=



L2103AAWR-**
(L0503AAWR-**(not shown))



L2103AAWR

+



7019-9**G
(L05: 7144-9**(not shown))

=



L2103AAWR-**G
(L0503AAWR-**G (not shown))



L2103AAWR

+



7019-9**C

=



L2103AAWR-**C



L2103AAWR

+



7019-9**Y

=



L2103AAWR-**Y

C



Top Mount Spool Valves

Electrical Information

5/2

5/3

Top Mount Spool Valves

Part Numbers

Description	Series	Operator Type	Instructions	Wt. Kg(lb)	Coil Part Number **=Voltage
Weather-Proof DIN 43650C Connection NEMA 4X	L05	W	Order coil separately (specify voltage code from table below)	0,002 (0.06)	7144-9**
Weather-Proof 18" Leads NEMA 4X	L05	W	Order coil separately (specify voltage code from table below)	0,002 (0.06)	7144-9**G
Weather-Proof DIN 43650 Industrial Form B Connection NEMA 4X	L07 L21 L45	W	Order coil separately (specify voltage code from table below)	0,05 (0.12)	7019-9**
Weather-Proof 18" Leads NEMA 4X	L07 L21 L45	W	Order coil separately (specify voltage code from table below)	0,05 (0.12)	7019-9**G
Weather-Proof 1/2" Conduit with 30" Leads NEMA 4X	L07 L21 L45	W	Order coil separately (specify voltage code from table below)	0,05 (0.12)	7019-9**C 7019-9**CT (high temp 82°C max)
Explosion-Proof 1/2" Conduit with 24" Leads CSA & FM Approved CL. I; Zone1 ExmII T4; AExmII CL. I; Div.1; GR. A, B, C, D CL. II; GR. E, F, G CL. III T4 Ta=-20°C to +60°C NEMA 4, 4X, 7C, 7D, 9	L07 L21 L45	W	Order coil separately (specify voltage code from table below)	0,20 (0.44)	7019-9**Y
Intrinsically-Safe Strain Relief Ex ia CL. I; GR. A,B,C,D CL. II; GR.E,F,G CL. III; Div.1; T5	L07 L21 L45	V	Coil and Connector included with valve (24VDC only)	0,21 (0.46)	A7106-374-DB

A7106-374 Must be Used with an Intrinsically-Safe Barrier
For more information refer to "Intrinsic Safety" insert on Page D7.

C

Voltage Codes (Lower wattage options available, consult factory)

L05		Current (Amps)		Resist. (OHMS @ 25°C)	Power (AC=VA, DC=Watts)	L07, L21, L45				Resistance (OHMS @ 25°C)		Power (AC=VA, DC=Watts)								
		Inrush	Holding			Current (Amps)		Resistance (OHMS @ 25°C)		Power (AC=VA, DC=Watts)										
Operator Type:		W	W	W	W	V	W	V	W	V	W	V	V							
** Code	Voltage +/-10%	NEMA				** Code	Volt. +/-10%	NEMA	Ex ia	NEMA	Ex ia	NEMA	Ex ia							
		4	4	4	4		4	7&V	4	7	4	7	4	7	4	7	Ex ia			
DA	20/50 20/60	.10	.09	78	2.4	DA	24/50 24/60	-	.36	-	-	.24	-	-	32	-	-	6.9	-	-
AA	110/50 110/60	.02	.02	2310	2.4	AA	120/50 120/60	120/60	.08	.10	-	.05	.05	-	840	530	-	6.9	6.5	-
AB	220/50 220/60	.01	.01	9515	2.4	AB	230/50 230/60	240/60	.04	.05	-	.03	.03	-	3310	2345	-	6.4	6.8	-
DA	12VDC	.15	.15	78	2.0	DA	12VDC	12VDC	.38	.38	-	.38	.38	-	32	32	-	4.8	4.5	-
DB	24VDC	.09	.09	283	2.0	DB	24VDC	24VDC	.20	.19	.05	.20	.19	.05	121	128	275	4.8	4.5	1.6
AB	125VDC	.02	.02	9515	2.0	AB	125VDC	-	.04	-	-	.04	-	-	3310	-	-	5.9	-	-

Connectors (Not Polarity Dependent)

DIN 43650 Industrial Form B	L05 Connectors				L07, L21, L45 Connectors					
Type	Strain Relief without Cord	Light & 6' Cord		Strain Relief without Cord	1/2" Conduit without Cord	Molded with 6' Cord	Strain Relief with Light		Strain Relief with Light & 6' Cord	
		120/60 AC	24 VDC				100-240 AC 48-120 DC	6-48 AC/DC	100-240 AC 48-120 DC	6-48 AC/DC
P/N	7144-001	7144-002	7144-003	7020-001	7039-001	7020-006	7020-AA	7020-DB	7094-006	7094-007

5/2



5/3



Top Mount Spool Valves

Service Information

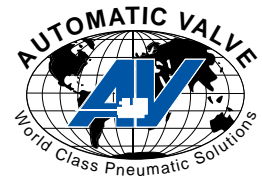

Valve must be disconnected from all air and electrical power sources before disassembly.

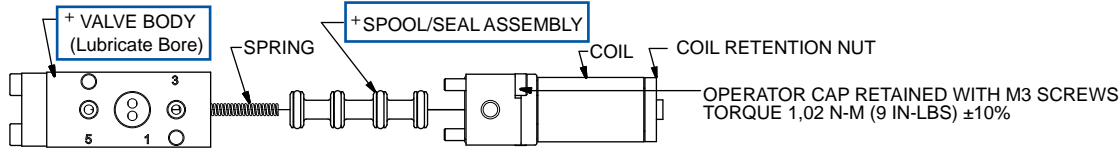

Shown: L05 Single 2 Position Valve

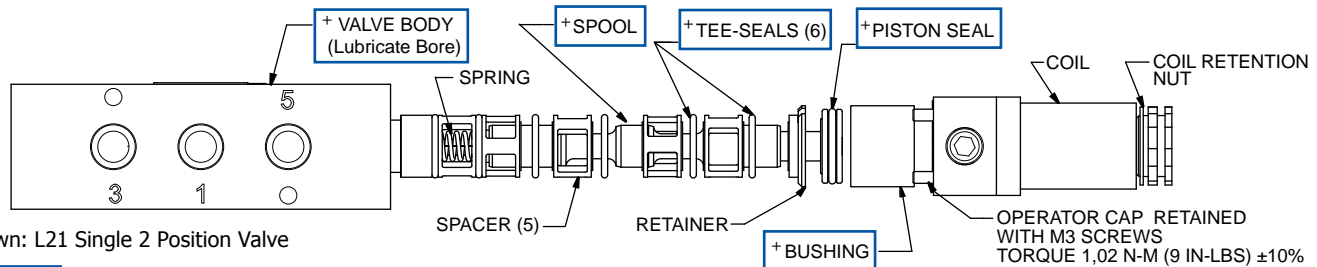

Shown: L21 Single 2 Position Valve

+ = items that must be lubricated

Service Kit Installation Instructions

- Follow appropriate lock-out/tag-out procedures. Do not attempt to service a valve, if you are not familiar with lock-out/tag-out procedures.
- Turn off electrical power to the valve.
- Remove valve from all electrical and air power sources.
- Ensure all stored air power is exhausted.
- Remove coil by first removing the coil retention nut.
- Remove operator cap by first removing socket head cap screws (L05: 2 screws) (L07, L21, & L45: 4 screws).
- Remove existing serviceable components by "pushing" internal components gently out of the valve body.
- For L05, discard spool.
For L07, L21, or L45, clean the spool with a clean cloth.
- Discard the spring (Single Spring Return models only).
- Lubricate the designated "+" items in the above assembly drawing with a thin film of lubricant - the item should look "WET" with no excess lubricant visible.
- Replace components as shown above.
For L05:
 - Replace spring and spool.
 For L07, L21 & L45:
 - Replace spring pad and spring (Single Spring Return models only).
 - Alternate Tee-seals and spacers.
 - Once all 6 Tee-seals are installed, replace the spool, retainer, bushing and piston.
- Orientate the operator cap by aligning the open end of the gasket with the pilot hole in the valve body.
- Torque cap screws into body to 1,02 N-m (9 in-lbs) ±10%. Alternate tightening of the screws, so cap "squeezes" evenly onto the body.

Air Line Lubrication of Automatic Valve products is not required, but is recommended to maximize service life. Oils should be compatible with seal material, have an ISO 32 or lighter viscosity, and have an aniline point between 82°C (180°F) and 99°C (210°F). Refer to the Maintenance Section of this catalog for recommended lubricants.

Model Numbers: Service Kits

Series	Function			
	Single		Double	
	Model Number	Contents	Model Number	Contents
L05	K-L05-SGL	Spool/Seal Assembly (1), Spring (1)	K-L05-DBL	Spool/Seal Assembly (1)
L07	K-L07-SGL	Tee-Seals (6), Piston Seal (1), Spring (1)	K-L07-DBL	Tee-Seals (6), Piston Seals (2)
L21	K-L21-SGL K-L21-SGL-A (fluoroelastamer)	Tee-Seals (6), Piston Seal (1), Spring (1)	K-L21-SGL K-L21-SGL-A (fluoroelastamer)	Tee-Seals (6), Piston Seals (2)
L45	K-L45-SGL K-L45-SGL-A (fluoroelastamer)	Tee-Seals (6), Piston Seal (1), Spring (1)	K-L45-SGL K-L45-SGL-A (fluoroelastamer)	Tee-Seals (6), Piston Seals (2)

AV AUTOMATIC VALVE

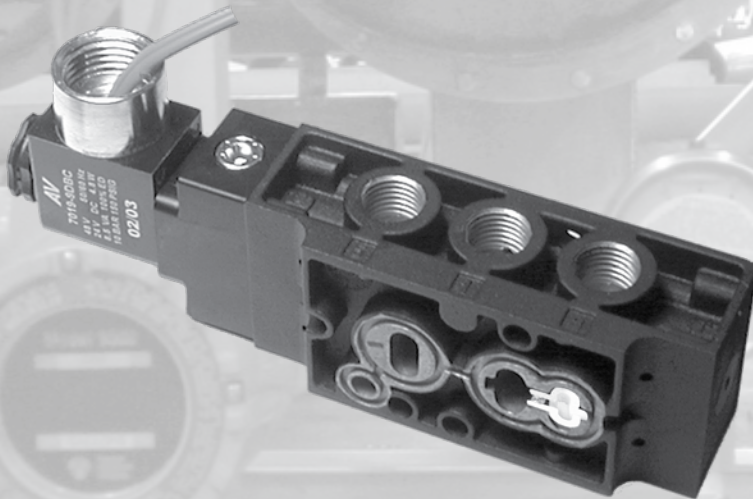

NAMUR Actuator Solenoids

	Page
Design Features	D2
Specifications	D3
Model Numbers	D3
Standard Solenoid	D4-D5
Intrinsically-Safe Solenoid	D6-D7
Bar Stock Solenoid	D8-D9
Options	D10-D11
Accessories	D11-D13
Configuration Example	D14
Electrical Information	D15
Service Information	D16
4 Way / 3 Way Conversion	D17

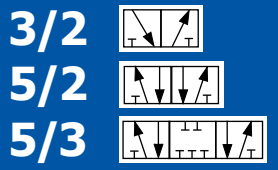

NAMUR Actuator Solenoids

Design Features

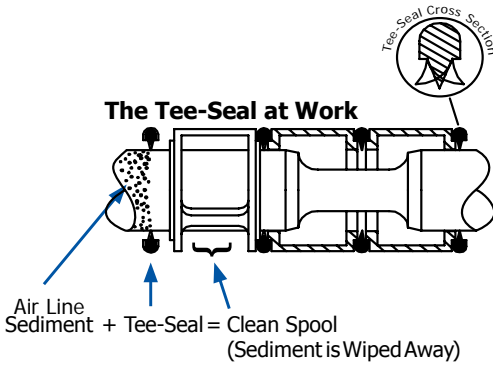
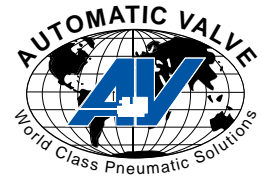

Valves

- Proven design with over 20 years OEM experience.
- Many options available to meet your requirements including:
 - Explosion proof and intrinsically safe operators
 - Stainless Steel
 - Fluoroelastomer Seals
- Easily converted from 4 way to 3 way operation
- Specific application needs? Consult the factory. We will build it for you.



Tapered Tee-Seal Eats Dirt

- Bidirectional tapered Tee-Seal eliminates sticking problems.
 - Flexes to clean spool
 - Mechanically Locked
 - No Spiral Twist
 - No Extrusion
 - Air Line Sediment is Wiped Away.
- Tested tough and proven reliable according to SAE specifications: Rust and water injected every 864,000 cycles for 20 million cycles.



Solenoid ... Guaranteed Against Burnout

- Three-way pilot uses full air line pressure to shift the valve.
- Pilot is internally supplied when the pressure at port one is 35 to 150 PSIG (240 to 1030 kPa).
- Coil is hermetically sealed as an integral watertight molded unit.
- Intrinsically-safe and explosion-proof versions available.
- Push Non-Locking Override is standard. (Extended Turn and Turn-Locking available)



Products Certified To:

- CSA - (C22.2 and UL STD 429)
- Factory Mutual - Explosion Proof Environments
- ATEX - Explosion Proof Environments
- CE - EMF and Low Voltage Directives



NAMUR Actuator Solenoids

Specs & Model Numbers

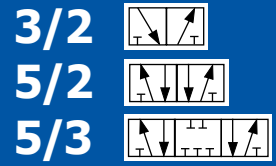

NAMUR Actuator Solenoids

Specifications

Valve Operation		Valve Operation	
<p>3/2 NORMALLY CLOSED De-Energized: Exhausts Pressure Port 4 to Port 5 Energized: Applies Pressure Port 1 to Port 4 Vents through Ports 3/2 & 3</p> <p>DE-ENERGIZED 10 ENERGIZED 14</p>	<p>5/3 BLOCK Maintained Energized 12: Pressure from Port 1 to Port 2 Exhaust from Port 4 to Port 5 De-Energized:All ports Blocked Maintained Energized 14: Pressure from Port 1 to Port 4 Exhaust from Port 2 to Port 3</p> <p>ENERGIZED 12 DE-ENERGIZED ENERGIZED 14</p>		
<p>5/2 SINGLE De-Energized: Pressure from Port 1 to Port 2 Exhaust from Port 4 to Port 5 Energized: Pressure from Port 1 to Port 4 Exhaust from Port 2 to Port 3</p> <p>DE-ENERGIZED 12 ENERGIZED 14</p>	<p>5/3 EXHAUST Maintained Energized 12: Pressure from Port 1 to Port 2 Exhaust from Port 4 to Port 5 De-Energized: Port 2 open to Port 3, Port 4 open to Port 5 Port 1 Blocked Maintained Energized 14: Pressure from Port 1 to Port 4 Exhaust from Port 2 to Port 3</p> <p>ENERGIZED 12 DE-ENERGIZED ENERGIZED 14</p>		
<p>5/2 DOUBLE Momentarily Energized 12: Pressure from Port 1 to Port 2 Exhaust from Port 4 to Port 5 Momentarily Energized 14: Pressure from Port 1 to Port 4 Exhaust from Port 2 to Port 3</p> <p>ENERGIZED 12 ENERGIZED 14</p>	<p>5/3 PRESSURE Maintained Energized 12: Pressure from Port 1 to Port 2 Exhaust from Port 4 to Port 5 De-Energized: Port 1 open to Ports 2 & 4; Ports 3 & 5 Blocked Maintained Energized 14: Pressure from Port 1 to Port 4 Exhaust from Port 2 to Port 3</p> <p>ENERGIZED 12 DE-ENERGIZED ENERGIZED 14</p>		
Operating Temperatures	Solenoid Pilot Operated	Treated Buna-N Seals (Treated NBR, Standard)	Fluoroelastomer Seals (FPM (FKM), Option A)
	Standard	-18°C to +50°C (0°F to +123°F)	-18°C to +50°C (0°F to +123°F)
	High Temp Coil (Option C T)	-18°C to +82°C (0°F to +180°F)	-18°C to +82°C (0°F to +180°F)
Operating Pressures	Solenoid Pilot Operated	Inlet Port	External Pilot Port
	Standard 2 Position	240 - 1030 kPa (35 - 150 PSIG)	-
	Standard 3 Position	345 - 1030 kPa (50 - 150 PSIG)	-
	External Pilot (Option B)	Vacuum - 240 kPa (Vacuum - 35 PSIG)	240 - 1030 kPa (35 - 150 PSIG)
Filtration & Lubrication	Media - Air Or Inert Gas		
	Air Line Lubrication of Automatic Valve products is not required, but is recommended to maximize service life. Oils should be compatible with seal material, have an ISO 32 viscosity, and have an aniline range between 82°C (180°F) and 99°C (210°F). Filter to 50 microns or better. For temperatures below 40°F, air must be dry to prevent formation of ice. Refer to the Maintenance section of this catalog for recommended lubricants.		

Model Numbers

Series	Body Type	Port Size	Function	Body Design	Operator 1	Center Oper	Operator 2	Voltage ¹	Options*
D06	0	NAMUR	3 1/4	G 3 Way NC	A Right	V	R 2 Position Spring	-AA	A Fluoroelastomer Seals B External Pilot Connection C Conduit Coil CT Conduit Coil High Temperature D Dustproof G 18" Flying Leads L Low Watt Coil (2.5 Watts) LL Lowest Watt Coil (0.7 Watts) P Transition Plate (D20 only) Q Closed Loop (D20 only) S 303 Stainless Steel Body (D20 Bar Stock) SS 316 Stainless Steel Body (D20 Bar Stock) W G (BSPP) Threads Y Explosion-Proof Coil (CSA,FM) Z Explosion-Proof Coil (ATEX, PTB) 1 Push Turn-Locking Override 2 Extended Turn-Locking Override 4 No Override 8 10-24 Mounting Kit 9 10-32 Mounting Kit
								W Weather-Proof Solenoid	
D20	0	NAMUR	3 1/4	A 4 Way 2 Position	A Right	A Air Pilot	D 3 Pos'n Spring	-DB 24VDC	
				C 4 Way 3 Position Block Ctr	B Double Left	V Intrinsicly-Safe Solenoid (24VDC only)	R 2 Position Spring		
				D 4 Way 3 Position Exhaust Center	C Left	W Weather-Proof Solenoid	V Intrinsicly-Safe Solenoid (24VDC only)		
				E 4 Way 3 Position Pressure Center			W Weather-Proof Solenoid		
			G 3 Way NC (Die Cast only)						

* Not all Options are available for all models. Refer to "Options" at the end of this Section for additional information.

¹ Consult the Factory for additional voltages.

3/2
5/2
5/3

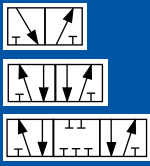

NAMUR Actuator Standard Solenoids

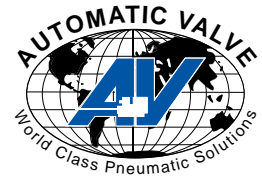

D06



D0603GAWR

D20



LEFT: D2003ACWR



RIGHT: D2003AAWR



Model Numbers

	Function		Port Size	Flow l/min (Cv)	Model Number	Materials		Weight kg (lb)
	Description	Schematic				Body	Seal	
3/2	Normally Closed Single		1/4	59 (0.06)	D0603GAWR-**	Aluminum	-	0,26 (0.58)
	Normally Closed Single Left		1/4	1770 (1.8)	D2003GCWR-**	Aluminum	NBR	0,32 (0.70)
	Normally Closed Single Right				D2003GAWR-**			
5/2	Single Left		1/4	1770 (1.8)	D2003ACWR-**	Aluminum	NBR	0,26 (0.57)
	Single Right				D2003AAWR-**			
	Double				D2003ABWW-**			0,34 (0.75)
5/3	Block Double		1/4	1381 (1.4)	D2003CBWDW-**	Aluminum	NBR	0,36 (0.80)
	Exhaust Double				D2003DBWDW-**			
	Pressure Double				D2003EBWDW-**			

** = Coil Voltage Code. Coils also sold separately. Refer to "Electrical Information" at the end of this Section for additional information.

Dimensional Information

D06

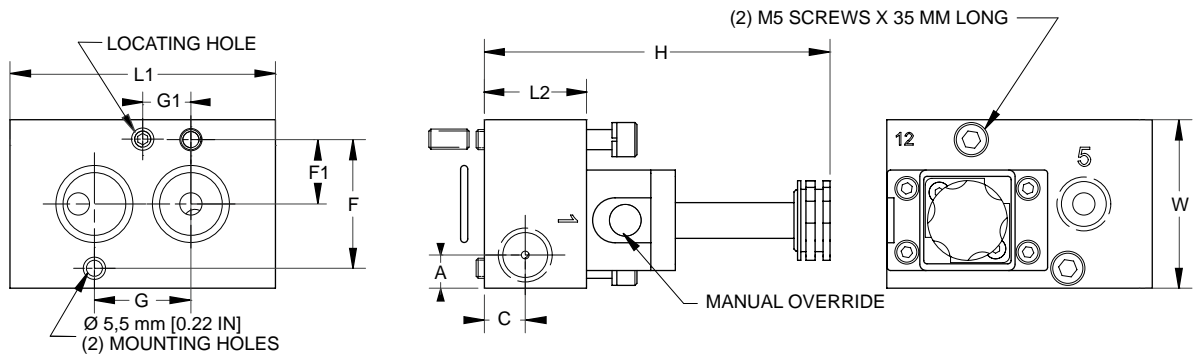

D20

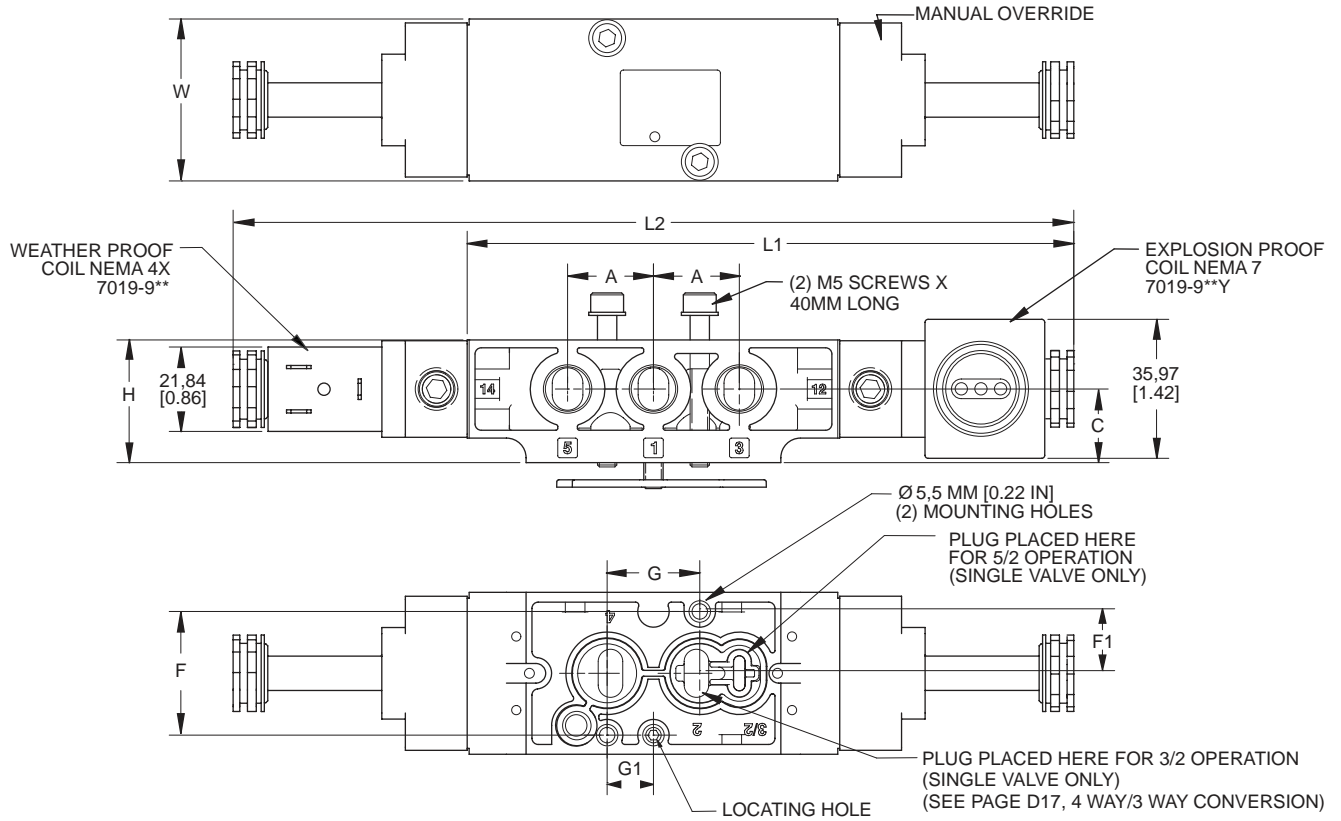

Series	Description	A	C	F	F1	G	G1	H	L1	L2	W
D06	Single	8,4 0.33	10,2 0.40	32,0 1.26	16,0 0.63	23,9 0.94	11,9 0.47	85,1 3.35	66,0 2.60	25,4 1.00	41,9 1.65
D20	Single	22,2 0.88	19,1 0.75	32,0 1.25	16,0 0.63	23,9 0.94	11,9 0.47	31,7 1.25	157 6.15	-	41,9 1.65
	Double	22,2 0.88	19,1 0.75	32,0 1.26	16,0 0.63	23,9 0.94	11,9 0.47	31,7 1.25	-	217 8.55	41,9 1.65

Units of Measure: Top - mm, Bottom - inches

3/2
5/2
5/3

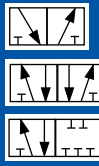

NAMUR Actuator Intrinsically-Safe Solenoids

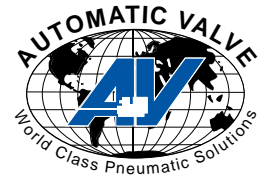

D06



D0603GAVR-DB

D20



LEFT: D2003GCVR-DB



RIGHT: D2003GAVR-DB



DOUBLE: D2003ABVV-DB

Model Numbers

	Function		Port Size	Flow l/min (Cv)	Model Number	Materials		Weight kg (lb)
	Description	Schematic				Body	Seals	
3/2	Normally Closed Single		1/4	59 (0.06)	D0603GAVR-DB	Aluminum	-	0,26 (0.58)
	Normally Closed Single Left		1/4	1770 (1.8)	D2003GCVR-DB	Aluminum	NBR	0,32 (0.70)
	Normally Closed Single Right				D2003GAVR-DB			
5/2	Single Left		1/4	1770 (1.8)	D2003ACVR-DB	Aluminum	NBR	0,32 (0.70)
	Single Right				D2003AAVR-DB			
	Double				D2003ABVV-DB			
5/3	Block Double		1/4	1381 (1.4)	D2003CBVDV-DB	Aluminum	NBR	0,36 (0.80)
	Exhaust Double				D2003DBVDV-DB			
	Pressure Double				D2003EBVDV-DB			

NAMUR Actuator Intrinsically-Safe Solenoids

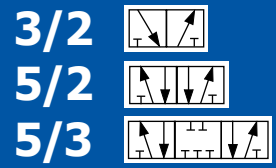

Dimensional Information

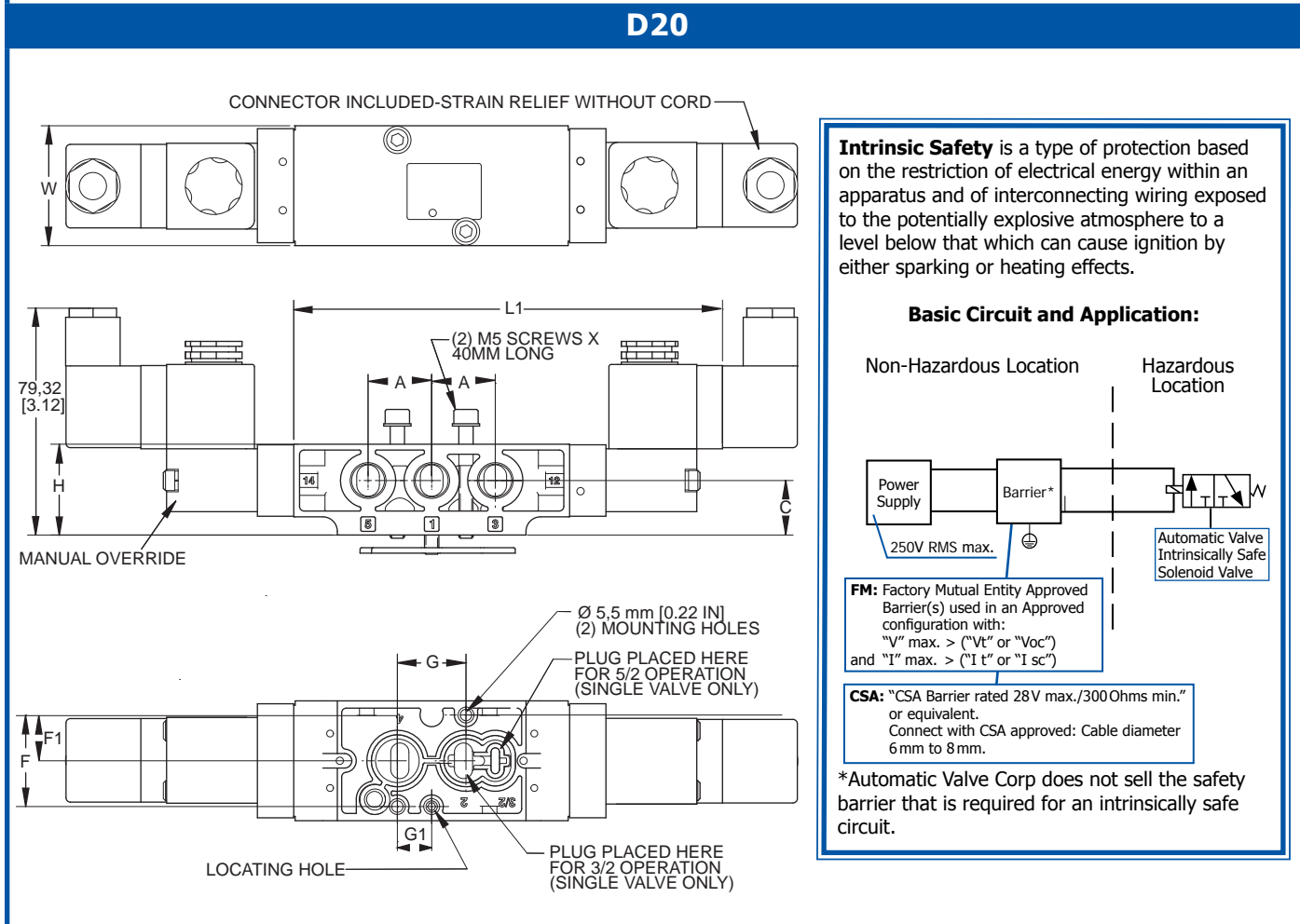
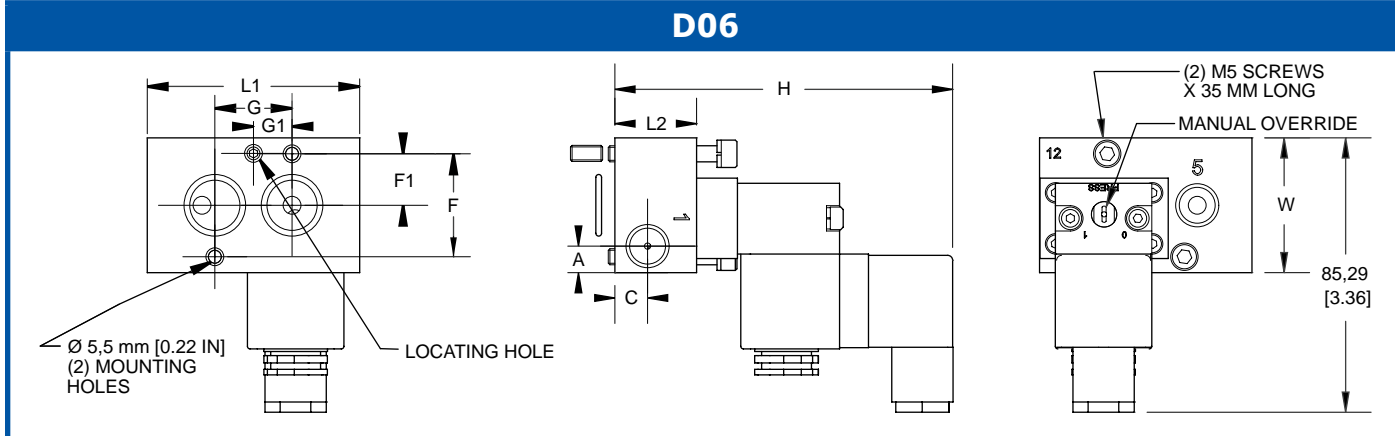

Intrinsic Safety is a type of protection based on the restriction of electrical energy within an apparatus and of interconnecting wiring exposed to the potentially explosive atmosphere to a level below that which can cause ignition by either sparking or heating effects.

Basic Circuit and Application:

Non-Hazardous Location Hazardous Location

Power Supply
250V RMS max.

Barrier*

Automatic Valve Intrinsically Safe Solenoid Valve

FM: Factory Mutual Entity Approved Barrier(s) used in an Approved configuration with:
"V" max. > ("Vt" or "Voc")
and "I" max. > ("It" or "Isc")

CSA: "CSA Barrier rated 28V max./300 Ohms min." or equivalent.
Connect with CSA approved: Cable diameter 6 mm to 8 mm.

*Automatic Valve Corp does not sell the safety barrier that is required for an intrinsically safe circuit.

Series	Description	A	C	F	F1	G	G1	H	L1	L2	W
D06	Single	8,4 0.33	10,2 0.40	32,0 1.26	16,0 0.63	23,9 0.94	11,9 0.47	107,2 4.22	85,8 3.38	25,4 1.00	41,9 1.65
	Double	22,2 0.88	19,1 0.75	32,0 1.26	16,0 0.63	23,9 0.94	11,9 0.47	68,3 2.69	149 5.86	-	41,9 1.65

Units of Measure: Top - mm, Bottom - inches

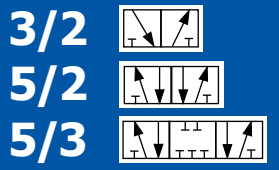

NAMUR Actuator Bar Stock Solenoids

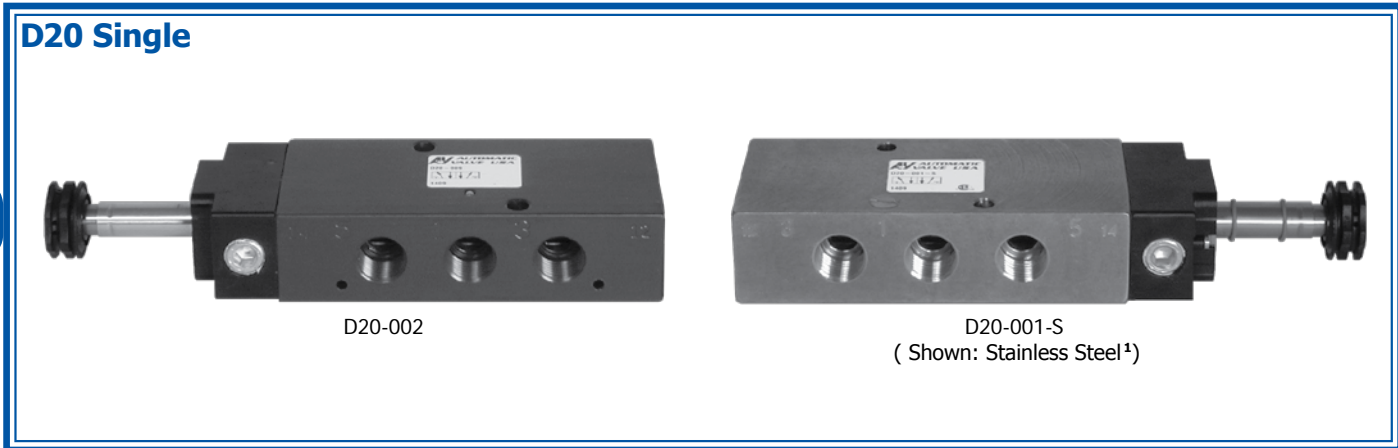
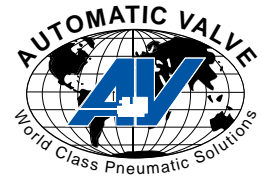

Model Numbers

	Function		Port Size	Flow l/min (Cv)	Model Number	Materials		Weight kg (lb)
	Description	Schematic				Body	Seal	
5/2	Single Left		1/4	1770 (1.8)	D20-002-**	Aluminum ¹	NBR	0,34 (0.75)
	Single Right				D20-001-**			
	Double				D20-009-**			
5/3	Block Double		1/4	1381 (1.4)	D20-037-C-**	Aluminum ¹	NBR	0,37 (0.82)
	Exhaust Double				D20-037-D-**			
	Pressure Double				D20-037-E-**			

** = Coil Voltage Code. Coils also sold separately. Refer to "Electrical Information" at the end of this Section for additional information.

¹ Body Available in 303 or 316 Stainless Steel. Refer to "Options" at the end of this Section for additional information.

Dimensional Information

D20 Single

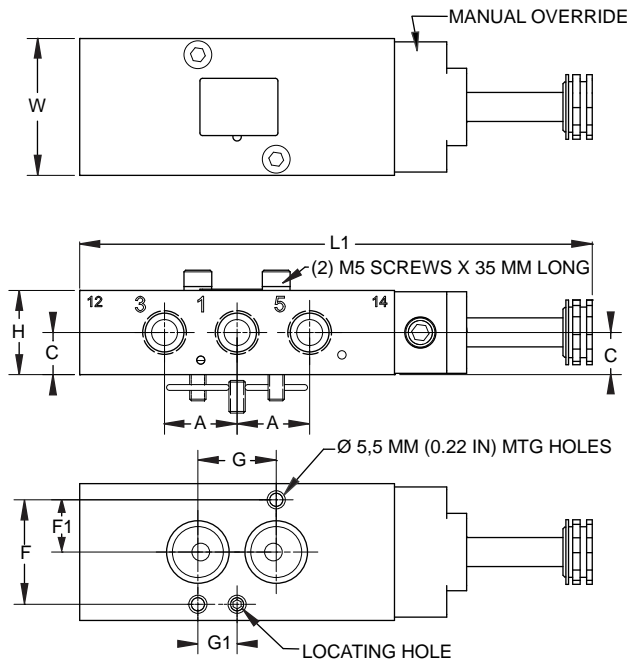

D20 Double

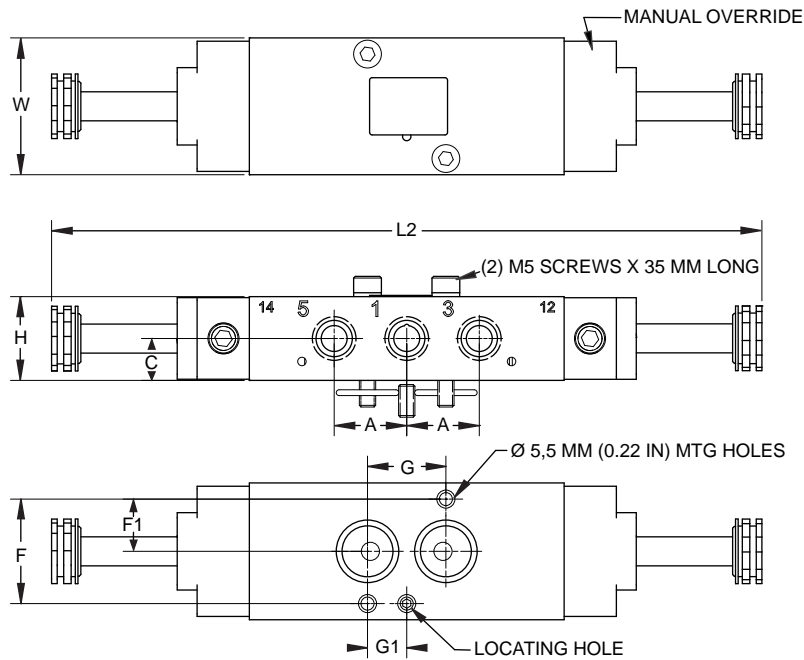

Series	Description	A	C	F	F1	G	G1	H	L1	L2	W
D20	Single	22,2 0.88	12,7 0.50	32,0 1.26	16,0 0.63	23,9 0.94	11,9 0.47	25,4 6.12	15,5 6.12	-	41,9 1.65
	Double	22,2 0.88	12,7 0.50	32,0 1.26	16,0 0.63	23,9 0.94	11,9 0.47	25,4 1.00	-	214 8.42	41,9 1.65

Units of Measure: Top - mm, Bottom - inches

3/2
5/2
5/3

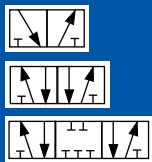

NAMUR Actuator Solenoids Options



Options (Add the suffix to the end of the model number in alpha-numeric order.)

Suffix	Option	Description
A	Fluoroelastomer Seals	For applications where fluid media or ambient conditions are not compatible with nitrile seals. (D20 only) <i>Note: Fluorocarbon seals do not increase the effective temperature range of the valve. For high temperature applications, consult the factory.</i>
B	External Pilot	For solenoid applications where the pressure to port one is less than 2 BAR (35 PSIG). See example below for field conversion. (D20 only)
		<p style="text-align: center;">Field Conversion</p> <ul style="list-style-type: none"> Remove solenoid and cap from the valve body. Rotate the gasket 180° so that the internal pilot hole in the valve body is covered by the gasket. Refasten the gasket, cap and solenoid to the valve body. Make sure the gasket completely covers the internal pilot hole before tightening the M3 screws. Torque to 1,02 N-m (9 in-lbs) ±10%. Remove the 1/8 NPTF pipe plug from the cap and make the external pilot connection.
C	Conduit Coil	Refer to the "Electrical Information" page in this section for details.
CT	Conduit Coil High Temperature	Refer to the "Electrical Information" page in this section for details.
D	Dustproof	For applications in extremely dusty and contaminated environments. Vent ports are plugged and spring pad breather vent is eliminated. (D20 only)
G	Coil With 18" Leads	Refer to the "Electrical Information" page in this section for details.
L	Low Watt Coil	Power Consumption = 2.5 Watts. Standard as Push Non-Locking Override. Also available with Option 2, Extended Turn-Locking Override.
LL	Lowest Watt Coil	Power Consumption = 0.7 Watts. Standard as Extended Turn-Locking Override.
P	Transition Plate	For mounting to surface pads smaller than 6,4 cm x 3,5 cm (2 1/2" x 1 3/8"). Refer to next page for Installation Instructions. (D20 only)
Q	Closed Loop	Exhaust feedback in closed loop position. (D20 only)
S	303 Stainless Steel	303 Stainless Steel body, all other external parts are corrosion resistant; for corrosive environment applications (D20 Bar Stock only).
SS	316 Stainless Steel	316 Stainless Steel body, all other external parts are corrosion resistant; for corrosive environment applications (D20 Bar Stock only).
W	G Threads	All ports tapped to metric "G" standard.
Y	Explosion-Proof Coil (CSA, FM)	Refer to the "Electrical Information" page in this section for details.
Z	Explosion-Proof Coil (Atex, PTB)	Refer to the "Electrical Information" page in this section for details.
1	Push Turn-Locking Override	Solenoid cap provides an override that is pushed in and turned to actuate & lock in the "on" position.
2	Extended Turn-Locking Override	Solenoid cap provides an extended override that is turned to lock in the "on" position.
4	No Override	Solenoid cap does not provide a manual override.
8	10-24 Mounting Kit	Mounting kit contains #10-24 mounting screws and set screw
9	10-32 Mounting Kit	Mounting kit contains #10-32 mounting screws and set screw

Option P: Transition Plate

The Transition Plate is designed for use in situations where the sealing face of the solenoid valve extends beyond the mounting surface.

(The minimum required mounting area measures 6,4 cm x 3,5 cm (2 1/2" x 1 3/8"))

Part Number

Option **P**: when ordering the plate with a valve
A8021-339: when ordering the plate only

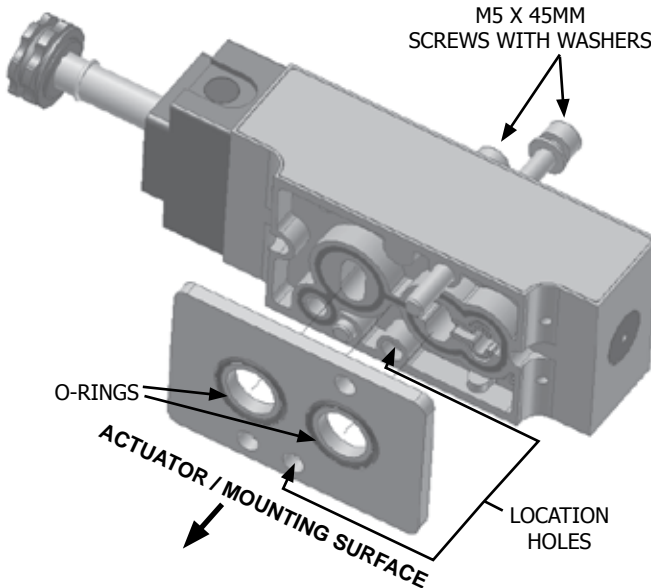

Installation Instructions: Transition Plate

1. Place the plate between the solenoid valve and the actuator with the o-rings facing the actuator.
2. Use the supplied **M5 x 45mm screws** to secure the solenoid valve/plate assembly to the mounting surface. These are the screws supplied in the plate kit, not those originally supplied with the valve. Do NOT use the shorter 40mm original screws; they will not engage properly.
3. Torque screws to 4,4-5,3 N-m (39-47 in-lbs) $\pm 10\%$ to effect a seal on the o-ring and gasket side of the transition plate.

D

Speed Control Valve

- For Bar Stock Models Only
- Mounts between the Directional Control Valve and the Actuator
- Mounts on the NAMUR pad
- Functions as a flow control for both cylinder ports
- Is easily adjustable, turn the needles clockwise to decrease speed and counterclockwise to increase speed
- Normal operating pressure: 2 to 10 BAR (35 to 150 PSIG)
- Normal operating temperature: -18°C to +52°C (0°F to +125°F)
- Approximate weight: 0,07 kg (0.16 lb)

Model Number
A7106-554

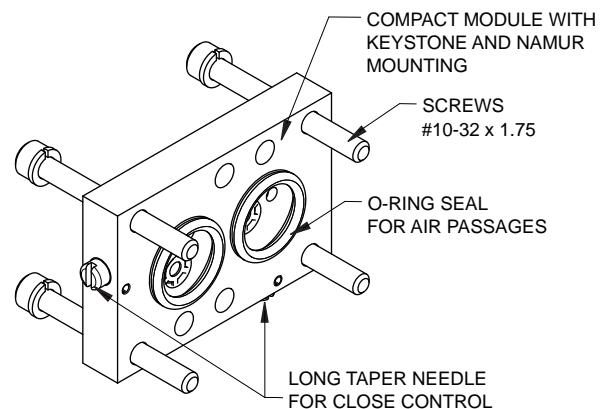
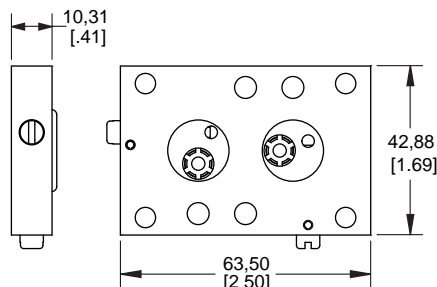
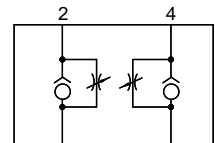

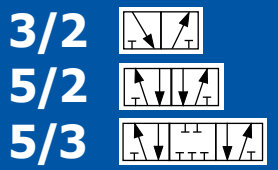

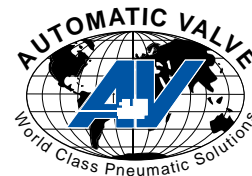

NAMUR Actuator Solenoids Accessories



Mufflers

Part Number	Description		Pipe Size NPT	Flow l/min (Cv)	Length mm (in)	Hex Size mm (in)	Weight kg (lb)
84C-2	<p>Exhaust Muffler</p> <ul style="list-style-type: none"> Reduces exhaust noise level in air systems. Maintains full volume air flow with minimum back pressure. Threads into exhaust port. 		1/4	2060 (2.3)	44,5 (1.75)	14,3 (9/16)	0,020 (0.044)
84D-2	<p>Sintered Exhaust Muffler</p> <ul style="list-style-type: none"> Reduces exhaust noise level in air systems. Sintered bronze bonded to a copper plated male pipe fitting. Corrosion resistant. Cleanable 40 micron filter element. 		1/4	600 (0.7)	33,3 (1.31)	14,3 (9/16)	0,017 (0.037)
266B-2	<p>Exhaust Restrictor/Sintered Muffler</p> <ul style="list-style-type: none"> Reduces exhaust noise level in air systems. Allows adjustment of exhaust air flow to accurately control cylinder speeds. Corrosion resistant. Cleanable 40 micron filter element. 		1/4	1160 (1.3)	55,9 (2.2)	14,3 (11/16)	0,026 (0.057)

D

90° Mounting Plate

- For Bar Stock Models Only
- Allows horizontal installation of the directional control valve.
- Orientates the valve 90° to the actuator.

Part Number
A8022-438

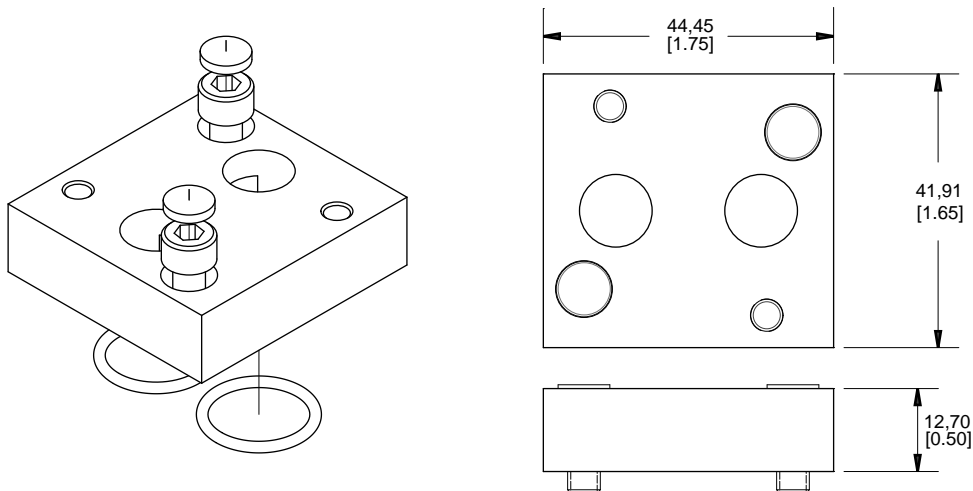

Quick Exhaust, Check and Shuttle Valves: Series: MQ2

One model does all three functions

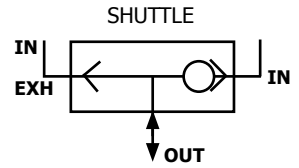
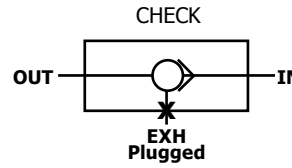
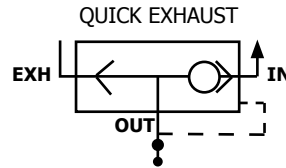

Features

- Rugged internal construction outlasts and out performs the competition.
- Quick Exhaust: When **IN** is pressurized, flow is from **IN** to **OUT** with **EXH** blocked. When **OUT** is pressurized, flow is from **OUT** to **EXH** with **IN** blocked
- Check Valve: Free flow from **IN** to **OUT** with **EXH** plugged. No flow from **OUT** to **IN** with **EXH** plugged.
- Shuttle Valve: When **IN** is pressurized, flow is from **IN** to **OUT** with **EXH** blocked. When **EXH** is pressurized, flow is from **EXH** to **OUT** with **IN** blocked.



370A-22

Model Numbers

Series	Model Number	Port Size NPTF		Flow l/min (Cv)	Pressure BAR (PSIG)		Weight Kg (lb)
		IN, OUT	EXH		Min	Max	
MQ2	370A-22	1/4	1/4	890 (0.97)	0.3 (4)	10.7 (150)	0,07 (0.16)

Dimensional Information

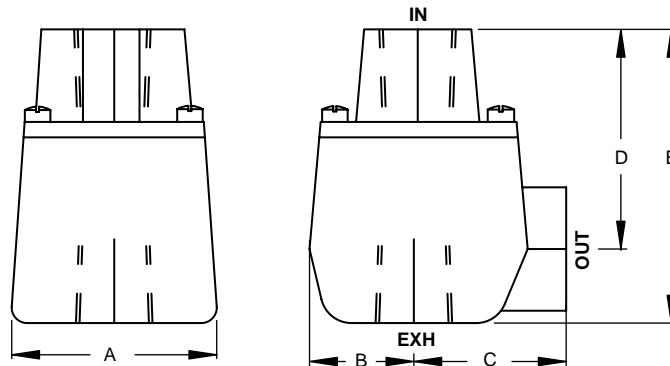

Series	Model Number	A	B	C	D	E
MQ2	370A-22	27,7 1.09	13,9 0.55	20,5 0.81	30 1.22	42,4 1.67

Units of Measure: Top-mm, Bottom-inches

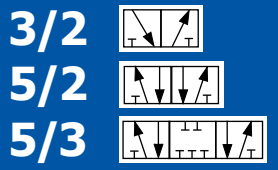

NAMUR Actuator Solenoids Configuration Example

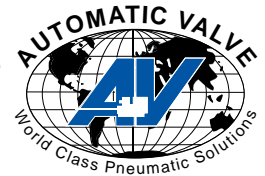

Valve With W-Solenoid Cap + Coil = Valve With Coil



D2003AAWR

+



NEMA 4x with DIN 43650 Form B Connection
7019-9**

=



D2003AAWR-**



D2003AAWR

+



NEMA 4x with 18" Leads
7019-9G**

=



D2003AAWR-G**

D



D2003AAWR

+



NEMA 4x 1/2" Conduit with 30" Leads
7019-9C**

=



D2003AAWR-C**



D2003AAWR

+



Explosion-Proof 1/2" Conduit with 24" Leads
7019-9Y**

=



D2003AAWR-Y**



D2003AAWR

+



ATEX Explosion-Proof with 39" Cable
7152-9**

=



D2003AAWR-Z**



NAMUR Actuator Solenoids

Electrical Information

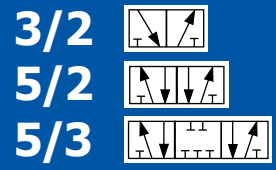

NAMUR Actuator Solenoids

Part Numbers

Description	Operator Type	Instructions	Wt. Kg(lb)	Coil Part Number **=Voltage
Weather-Proof DIN 43650 Industrial Form B Connection NEMA 4X	W	Order coil separately (specify voltage code from below)	0,05 (0.12)	7019-9**
Weather-Proof 18" Leads NEMA 4X	W	Order coil separately (specify voltage code from below)	0,05 (0.12)	7019-9**G
Weather-Proof 1/2" Conduit with 30" Leads NEMA 4X	W	Order coil separately (specify voltage code from below)	0,05 (0.12)	7019-9**C 7019-9**CT (high temp 82°C max)
Explosion-Proof 1/2" Conduit with 24" Leads CSA & FM Approved CL. I; Zone1 ExmIIT4; AExmII CL. I; Div.1; GR. A, B, C, D CL. II; GR. E, F, G CL. III T4 Ta=-20°C to +60°C NEMA 4, 4X, 7C, 7D, 9	W	Order coil separately (specify voltage code from below)	0,20 (0.44)	7019-9**Y
Intrinsically-Safe Strain Relief Ex ia CL. I; GR. A, B, C, D CL. II; GR. E, F, G CL. III; Div.1; T5	V	Coil and Connector included with valve (24VDC only)	0,21 (0.46)	A7106-374-DB
A7106-374 Must be Used with an Intrinsically-Safe Barrier For more information refer to "Intrinsic Safety" insert on Page D7.				
Explosion-Proof 3m Cable & Strain Relief Ex m II T5 PTB 03 ATEX2018 X Ex II 2 G EEx m II T5 Ex II 2 D IP65 T95°C	Z	Order coil separately (specify voltage code from below)	0,36 (0.78)	7152-9**

Voltage Codes (Lower wattage options available, consult factory)

** Code	Voltage +/- 10%		Current (Amps)								Resistance (OHMS @ 25°C)				Power (AC=VA, DC=Watts)							
	Operator Type:		Inrush				Holding				W		V		Z		W		V		Z	
	NEMA 4	NEMA 7,9 & ATEX	W		V		Z		W		V		Z		W		V		Z			
			NEMA	ATEX	NEMA	ATEX	NEMA	ATEX	NEMA	ATEX	NEMA	ATEX	NEMA	ATEX	NEMA	ATEX	NEMA	ATEX	NEMA	ATEX		
		4, 4x	7, 9	Exia	Exm	4, 4x	7, 9	Exia	Exm	4, 4x	7, 9	Exia	Exm	4, 4x	7, 9	Exia	Exm	4, 4x	7, 9	Exia	Exm	
DA	24/50 24/60	-	.36	-	-	-	.24	-	-	-	32	-	-	-	6.9	-	-	-				
AA	120/50 120/60	120/60	.08	.10	-	.04	.05	.05	-	.03	840	530	-	1664	6.9	6.5	-	3.4				
AB	230/50 230/60	240/60	.04	.05	-	.02	.03	.03	-	.01	3310	2345	-	6730	6.4	6.8	-	3.3				
DA	12 VDC	12VDC	.38	.38	-	.27	.38	.38	-	.27	32	32	-	45	4.8	4.5	-	3.5				
DB	24 VDC	24VDC	.20	.19	.05	.14	.20	.19	.05	.14	121	128	275	177	4.8	4.5	1.6	3.5				
AB	125 VDC	-	.04	-	-	-	.04	-	-	-	3310	-	-	-	5.9	-	-	-				

Connectors (Not polarity dependent)

DIN 43650 Industrial Form B	Maximum Cable Diameter: 9mm (0.35")		Strain Relief with Light		1/2" Conduit without Cord	Molded with 6' Cord	Strain Relief with Light & 6' Cord	
Type	Strain Relief without Cord	100-240 AC 48-120 DC	6-48 AC/DC	100-240 AC 48-120 DC	6-48 AC/DC	100-240 AC 48-120 DC	6-48 AC/DC	
Part Number	7020-001	7020-AA	7020-DB	7039-001	7020-006	7094-006	7094-007	

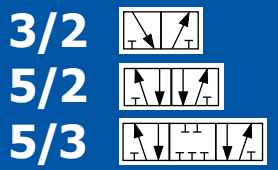

NAMUR Actuator Solenoids

Service Information

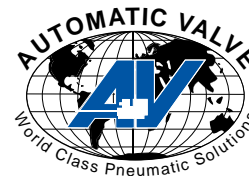

Valve must be disconnected from all air and electrical power sources before disassembly.

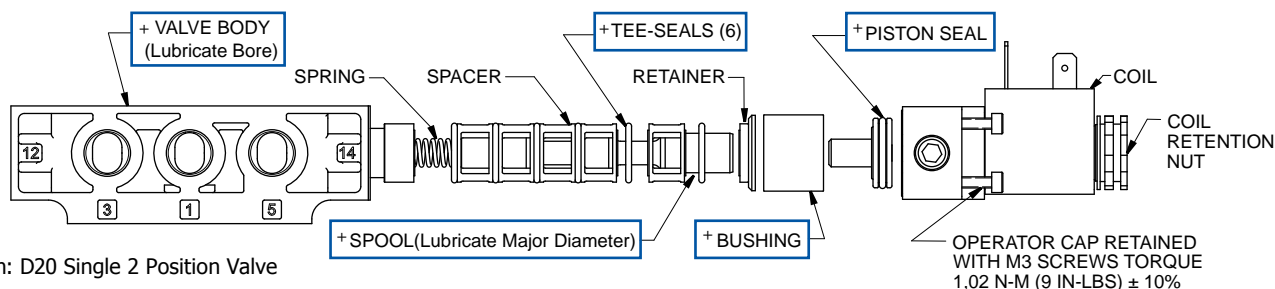

Shown: D20 Single 2 Position Valve

+ = Items that Must Be Lubricated

Service Kit Installation Instructions

- Follow appropriate lock-out/tag-out procedures. Do not attempt to service a valve, if you are not familiar with lock-out/tag-out procedures.
- Turn off electrical power to the valve.
- Remove valve from all electrical and air power sources.
- Ensure all stored air power is exhausted.
- Remove coil by first removing coil retention nut.
- Remove operator cap by first removing 4 socket head cap screws.
- Remove existing serviceable components by "pushing" internal components gently out of the valve body.
- Clean the spool with a clean cloth.
- Discard the spring (Single Spring Return Models Only).
- Lubricate the designated "+" items in the above assembly drawing with a thin film of lubricant - the item should look "WET" with no excess lubricant visible.
- Replace components as shown above.
 - Replace spring pad and spring (Single Spring Return Models Only).
 - Alternate Tee-seals and spacers.
 - Once all 6 Tee-seals are installed, replace the retainer, bushing and piston.
- Orientate the operator cap by aligning the open end of the gasket with the pilot hole in the valve body.
- Torque cap screws into body to 1,02 N-m (9 in-lbs) ±10%. Rotate tightening so that cap "squeezes" evenly onto body.

Air Line Lubrication of Automatic Valve products is not required, but is recommended to maximize service life. Oils should be compatible with seal material, have an ISO 32 or lighter viscosity, and have an aniline point between 82°C (180°F) and 99°C (210°F). Refer to the Maintenance Section of this catalog for recommended lubricants.

Model Numbers: Service Kits

Series	Body Style		
	Description	Model Number	Contents
D20	Single	K-L20-SGL K-L20-SGL-A (Fluoroelastomer)	Tee-Seals (6), Piston Seal (1), Spring (1), Lubricant
	Double	K-L20-DBL K-L20-DBL-A (Fluoroelastomer)	Tee-Seals (6), Piston Seals (2), Lubricant
	Standard Mounting Kit	A8021-340	Plug Assembly (1), Gasket (1), Screws (2), Set Screw (1), Washers (2), Lubricant
	Bar Stock Mounting Kit	A8022-618	O-Rings (2), Screws (2), Set Screws (2), Washers (2)

NAMUR Actuator Solenoids

4 Way/3 Way Conversion

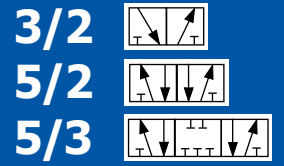

Views

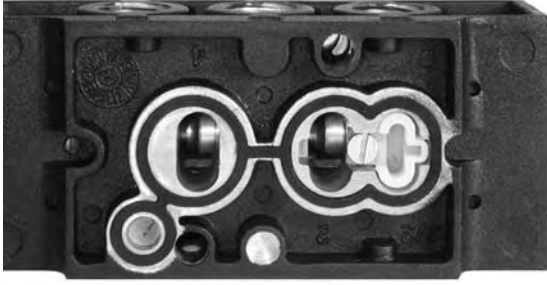
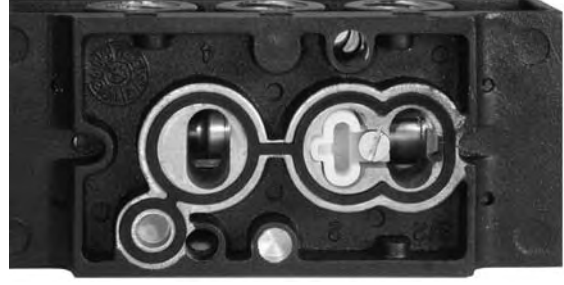
4 Way	3 Way
 <p>The D20 works as a 4 way when the plug is in the outer cavity.</p>	 <p>The D20 works as a 3 way when the plug is in the center cavity.</p>

Conversion Steps

4 Way to 3 Way Conversion

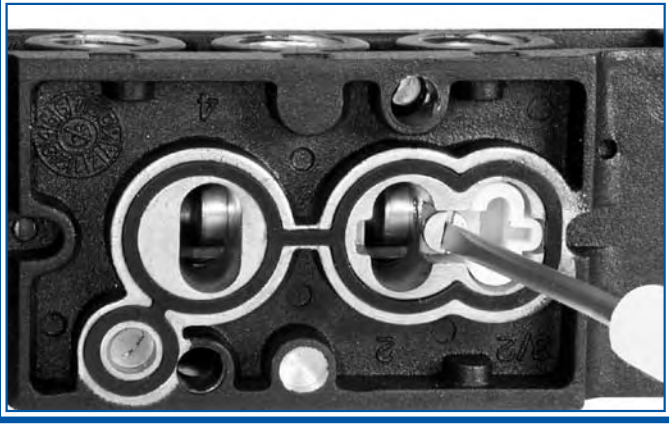

STEP 1: Using a 3 mm screwdriver loosen the plug retention screw.



STEP 2: Remove the plug. Lightly lubricate the plug and O-ring. Place plug in adjacent cavity.

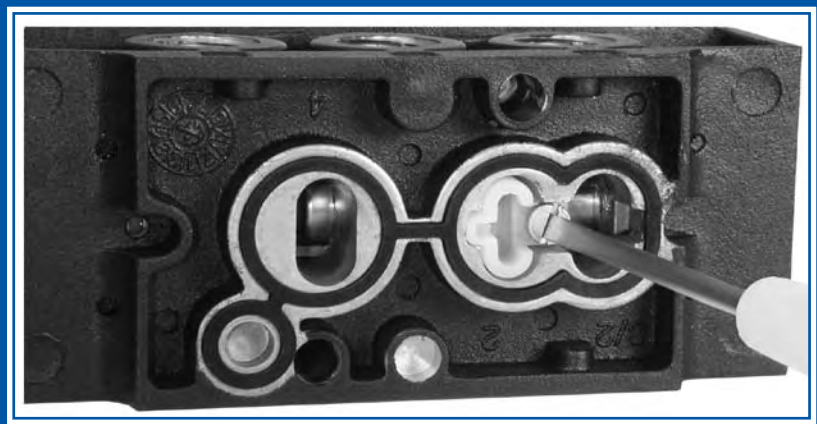

STEP 3: Tighten the plug retention screw to 0,68 N-m (6 in-lbs) ±10%.

Model Numbers

Series	Model Number	Contents
D20	A7216-081	Plug Assemblies (Qty 10) (screws/seals/plugs)

AV **AUTOMATIC VALVE**

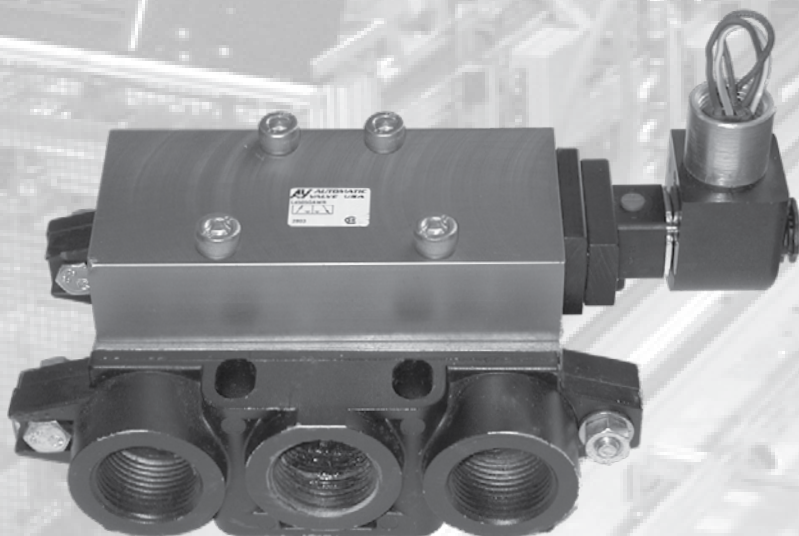
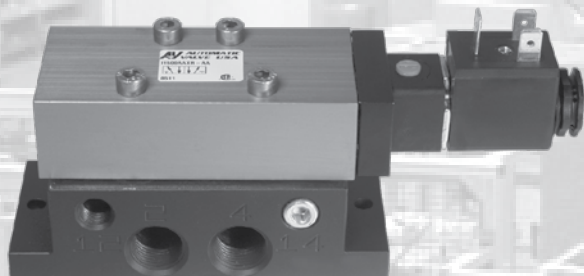

ISO Spool Valves

	Page
Design Features	E2
Specifications	E3
Model Number	E3
Standard Solenoid	E4-E5
Air Pilot	E6-E7
Manual	E8-E11
Sub-Bases & Manifolds	E12-E13
Configuration Example	E14
Electrical Information	E15
Options	E16
Service Information	E17

5/2



5/3

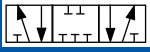

ISO Spool Valves Design Features

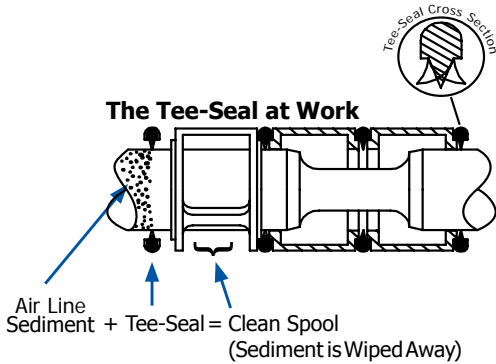

Valves

- Wide variety of options and operators available.
- Conforms to ISO 5599/1 specifications for size 1, 2 and 3.
- Specific application needs? Consult the factory. We can build it for you.

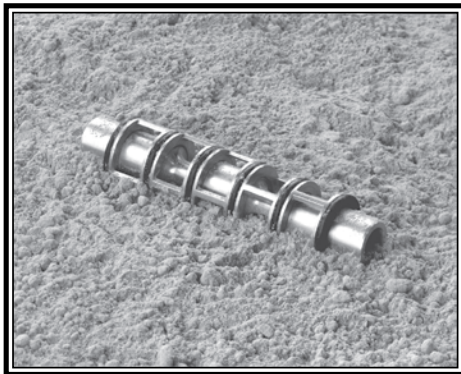

Tapered Tee-Seal..... Eats Dirt

- Bidirectional tapered Tee-Seal eliminates sticking problems.
 - Flexes to clean spool
 - Mechanically Locked
 - No Spiral Twist
 - No Extrusion
 - Air Line Sediment is Wiped Away.
- Tested tough and proven reliable according to SAE specifications: Rust and water injected every 864,000 cycles for 20 million cycles.

E



Solenoid ... Guaranteed Against Burnout

- Three-way pilot uses full air line pressure to shift the valve.
- Pilot is internally supplied when the pressure at port one is 35 to 150 PSIG (240 to 1030 kPa).
- Coil is hermetically sealed as an integral watertight molded unit.
- Intrinsically-safe and explosion-proof versions available.
- Push Turn-Locking Override is standard. (Extended Push Non-Locking is available)



Products Certified To:

- CSA - (C22.2 and UL STD 429)
- Factory Mutual - Explosion Proof Environments
- ATEX - Explosion Proof Environments
- CE - EMF and Low Voltage Directives



ISO Spool Valves Specs & Model Numbers

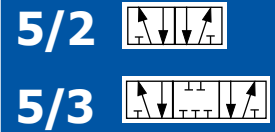

Specifications

Valve Operation		Valve Operation	
<p>115 120 145</p>	<p>ENERGIZED 12 DE-ENERGIZED ENERGIZED 14</p>	<p>5/3 BLOCK</p> <p>Maintained Energized 12: Pressure from Port 1 to Port 2 Exhaust from Port 4 to Port 5</p> <p>De-Energized: All ports Blocked</p> <p>Maintained Energized 14: Pressure from Port 1 to Port 4 Exhaust from Port 2 to Port 3</p>	
<p>DE-ENERGIZED 12 ENERGIZED 14</p>	<p>5/2 SINGLE</p> <p>De-Energized: Pressure from Port 1 to Port 2 Exhaust from Port 4 to Port 5</p> <p>Energized: Pressure from Port 1 to Port 4 Exhaust from Port 2 to Port 3</p>	<p>ENERGIZED 12 DE-ENERGIZED ENERGIZED 14</p>	<p>5/3 EXHAUST</p> <p>Maintained Energized 12: Pressure from Port 1 to Port 2 Exhaust from Port 4 to Port 5</p> <p>De-Energized: Port 2 open to Port 3, Port 4 open to Port 5 Port 1 Blocked</p> <p>Maintained Energized 14: Pressure from Port 1 to Port 4 Exhaust from Port 2 to Port 3</p>
<p>ENERGIZED 12 ENERGIZED 14</p>	<p>5/2 DOUBLE</p> <p>Momentarily Energized 12: Pressure from Port 1 to Port 2 Exhaust from Port 4 to Port 5</p> <p>Momentarily Energized 14: Pressure from Port 1 to Port 4 Exhaust from Port 2 to Port 3</p>	<p>ENERGIZED 12 DE-ENERGIZED ENERGIZED 14</p>	<p>5/3 PRESSURE</p> <p>Maintained Energized 12: Pressure from Port 1 to Port 2 Exhaust from Port 4 to Port 5</p> <p>De-Energized: Port 1 open to Ports 2 & 4; Ports 3 & 5 Blocked</p> <p>Maintained Energized 14: Pressure from Port 1 to Port 4 Exhaust from Port 2 to Port 3</p>
<p>Operating Temperatures</p>	<p>Solenoid Pilot Operated</p> <p>Standard</p> <p>High Temp Coil (Option CT)</p>	<p>Treated Buna-N Seals (Treated NBR, Standard)</p> <p>-18°C to +50°C (0°F to +123°F)</p> <p>-18°C to +82°C (0°F to +180°F)</p>	<p>Fluoroelastomer Seals (FPM (FKM), Option A)</p> <p>-18°C to +50°C (0°F to +123°F)</p> <p>-18°C to +82°C (0°F to +180°F)</p>
<p>Operating Pressures</p>	<p>Solenoid Pilot Operated</p> <p>Standard 2 Position</p> <p>Standard 3 Position</p> <p>External Pilot (Option B)</p>	<p>Inlet Port</p> <p>240 - 1030 kPa (35 - 150 PSIG)</p> <p>345 - 1030 kPa (50 - 150PSIG)</p> <p>Vacuum - 240 kPa (Vacuum - 35 PSIG)</p>	<p>External Pilot Port</p> <p>-</p> <p>-</p> <p>240 - 1030 kPa (35 - 150 PSIG)</p>
<p>Filtration & Lubrication</p>	<p>Media - Air Or Inert Gas</p> <p>Air Line Lubrication of Automatic Valve products is not required, but is recommended to maximize service life. Oils should be compatible with seal material, have an ISO 32 viscosity, and have an aniline range between 82°C (180°F) and 99°C (210°F). Filter to 50 microns or better. For temperatures below 40°F, air must be dry to prevent formation of ice. Refer to the Maintenance section of this catalog for recommended lubricants.</p>		

Model Numbers

Series	Body Type	Port Size	Function	Body Design	Operator 1	Center Operator	Operator 2	Voltage ²	Options*
115	0 Base	0 0	A 4 Way 2 Position	A Single	A Air Pilot	D 3 Pos'n Solenoid/Air	A Air Pilot	-AA 110/50, 120/60	A Fluoroelastomer Seals
			B 4 Way 2 Position ¹	B Double	F Hand Lever -Line	C 3 Position Spring Manual	-AB 220/50, 240/60, 125VDC	B External Pilot Connection	
120			C 4 Way 3 Position Blopk		I Palm Button	M 2 Position Detent Manual	M 2 Position Detent Manual	-DA 22/50, 24/60, 12VDC	C Conduit Coil
			D 4 Way 3 Position Exhaust		V Intrinsically-Safe Solenoid (24VDC only)	N 3 Position Detent Manual	-DB 24VDC	CT Conduit Coil High Temp	
145			E 4 Way 3 Position Pressure		X Weather-Proof Solenoid	R 2 Position Spring	R 2 Position Spring		D Dustproof
						V Intrinsically-Safe Solenoid (24VDC only)	V Intrinsically-Safe Solenoid (24VDC only)		G 18" Flying Leads
						X Weather-Proof Solenoid	X Weather-Proof Solenoid		LL2 Lowest Watt Coil (0.7 Watts) with Extended Turn-Locking Override
									Y Explosion-Proof Coil (CSA,FM)
									Z Explosion-Proof Coil (ATEX)
									5 Extended Push Non-Locking Override

* Not all Options are available for all models. Refer to "Options" at the end of this Section for additional information.

¹ Use varies. Consult the Factory for details. ² Consult the Factory for additional voltages.

5/2



5/3

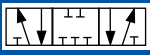

ISO Spool Valves Standard Solenoid

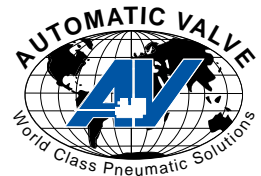

Single



I1500AAXR



I2000AAXR



I4500AAXR

Double



I1500ABXX



I2000CBDX

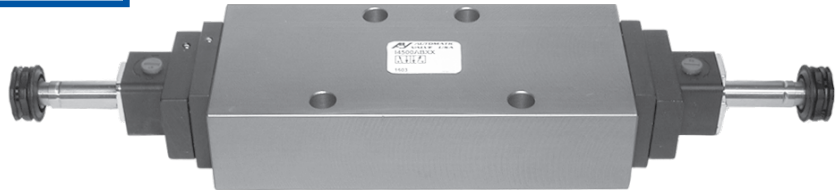

I4500EBDX

Model Numbers

Series	ISO Size	Port Loc'n	Flow l/min (Cv)		5/2		5/3			Mat'ls		Wt Kg (lb)
			5/2	5/3	Single	Double	Block	Exhaust	Pressure	Body	Seal	
I15	1	Base	1480 (1.5)	1154 (1.2)	I1500AAXR-**	I1500ABXX-**	I1500CBDX-**	I1500DBDX-**	I1500EBDX-**	Aluminum	NBR	0,4 (0.9)
I20	2		1970 (2.0)	1537 (1.6)	I2000AAXR-**	I2000ABXX-**	I2000CBDX-**	I2000DBDX-**	I2000EBDX-**			0,7 (1.5)
I45	3		4430 (4.5)	3455 (3.5)	I4500AAXR-**	I4500ABXX-**	I4500CBDX-**	I4500DBDX-**	I4500EBDX-**			0,9 (2.0)

** = Coil Voltage Code. Coils sold separately. Refer to "Electrical Information" at the end of this Section for additional information.

Dimensional Information

Single

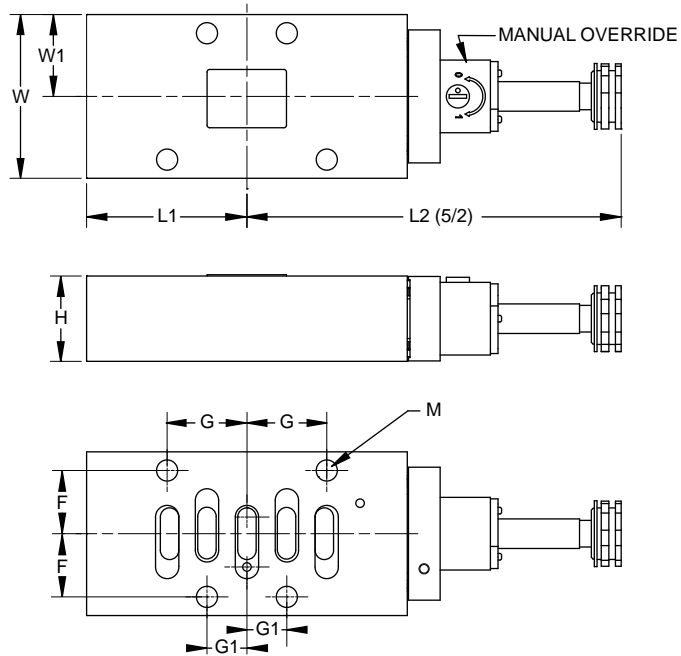

Double

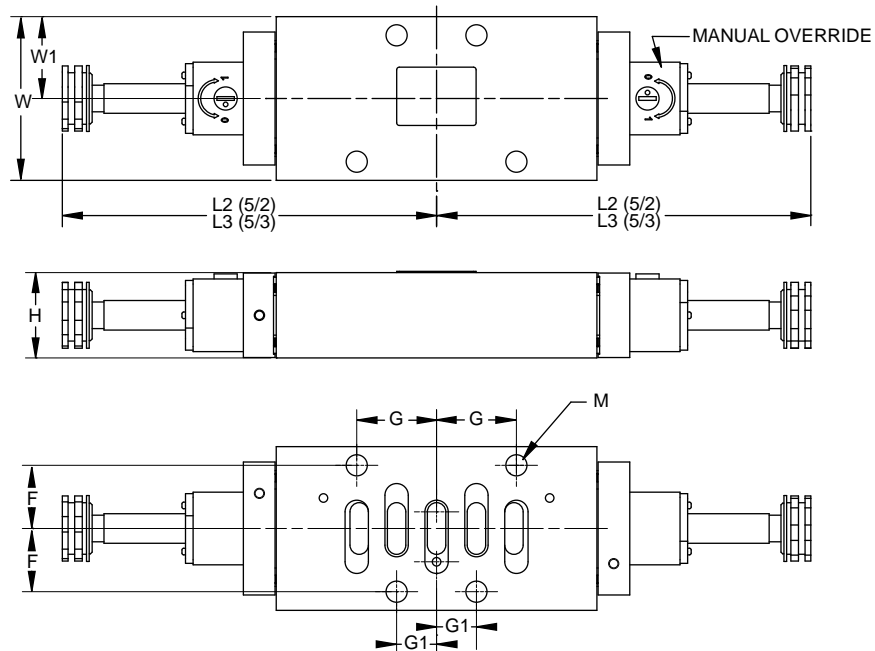

Series	ISO Size	F	G	G1	H	L1	L2	L3	M	W	W1
I15	1	14,0 0.55	18,0 0.71	9,0 0.35	25,4 1.00	44,3 1.74	108 4.26	108 4.26	5,4 0.21	41,9 1.65	21,0 0.83
I20	2	19,0 0.75	24,0 0.95	12,0 0.47	25,4 1.00	48,2 1.90	113 4.43	113 4.43	6,4 0.25	49,2 1.94	24,6 0.97
I45	3	24,0 0.95	32,0 1.26	16,0 0.63	31,8 1.25	69,0 2.72	138 5.43	138 5.43	8,7 0.34	63,5 2.50	31,8 1.25

Units of Measure: Top - mm, Bottom - inches

5/2



5/3

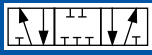

ISO Spool Valves Air Pilot

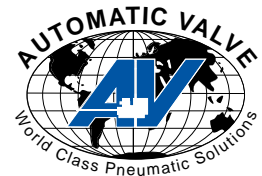

Single



I1500AAAR



I2000AAAR



I4500AAAR

Double



I1500ABAA



I2000ABAA



I4500ABAA

E

Model Numbers

Series	ISO Size	Port Loc'n	Flow l/min (Cv)		5/2		5/3			Mat'ls		Wt Kg (lb)
			5/2	5/3	Single	Double	Block	Exhaust	Pressure	Body	Seal	
I15	1	Base	1480 (1.5)	1154 (1.2)	I1500AAAR	I1500ABAA	I1500CBADA	I1500DBADA	I1500EBADA	Aluminum	NBR	0,4 (0.9)
I20	2		1970 (2.0)	1537 (1.6)	I2000AAAR	I2000ABAA	I2000CBADA	I2000DBADA	I2000EBADA			0,7 (1.5)
I45	3		4430 (4.5)	3455 (3.5)	I4500AAAR	I4500ABAA	I4500CBADA	I4500DBADA	I4500EBADA			0,9 (2.0)

Dimensional Information

Single

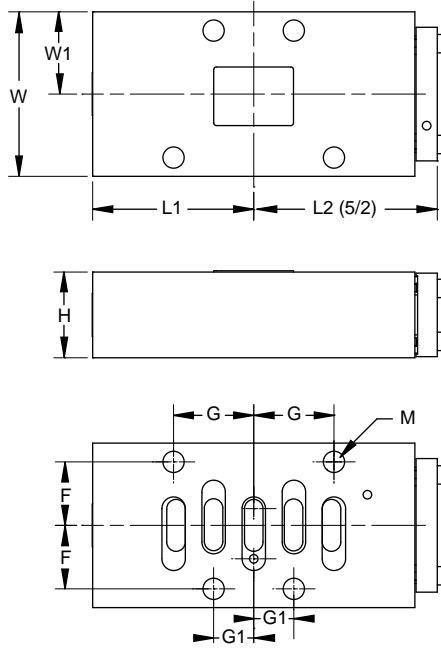

Double

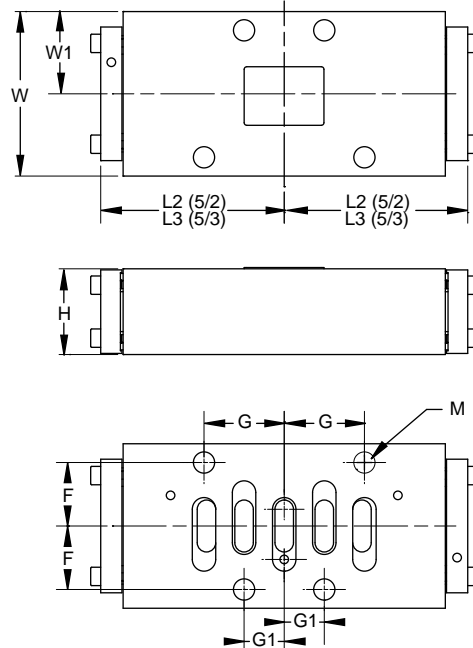

Series	ISO Size	F	G	G1	H	L1	L2	L3	M	W	W1
I15	1	14,0 0.55	18,0 0.71	9,0 0.35	25,4 1.00	44,3 1.74	50,8 2.00	50,8 2.00	5,4 0.21	41,9 1.65	21,0 0.83
I20	2	19,0 0.75	24,0 0.95	12,0 0.47	25,4 1.00	48,2 1.90	54,6 2.15	54,6 2.15	6,4 0.25	49,2 1.94	24,6 0.97
I45	3	24,0 0.95	32,0 1.26	16,0 0.63	31,8 1.25	69,0 2.72	75,4 2.97	75,4 2.97	8,7 0.34	63,5 2.50	31,8 1.25

Units of Measure: Top - mm, Bottom - inches



ISO Spool Valves Manual

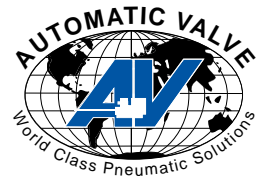

5/2 Hand Lever

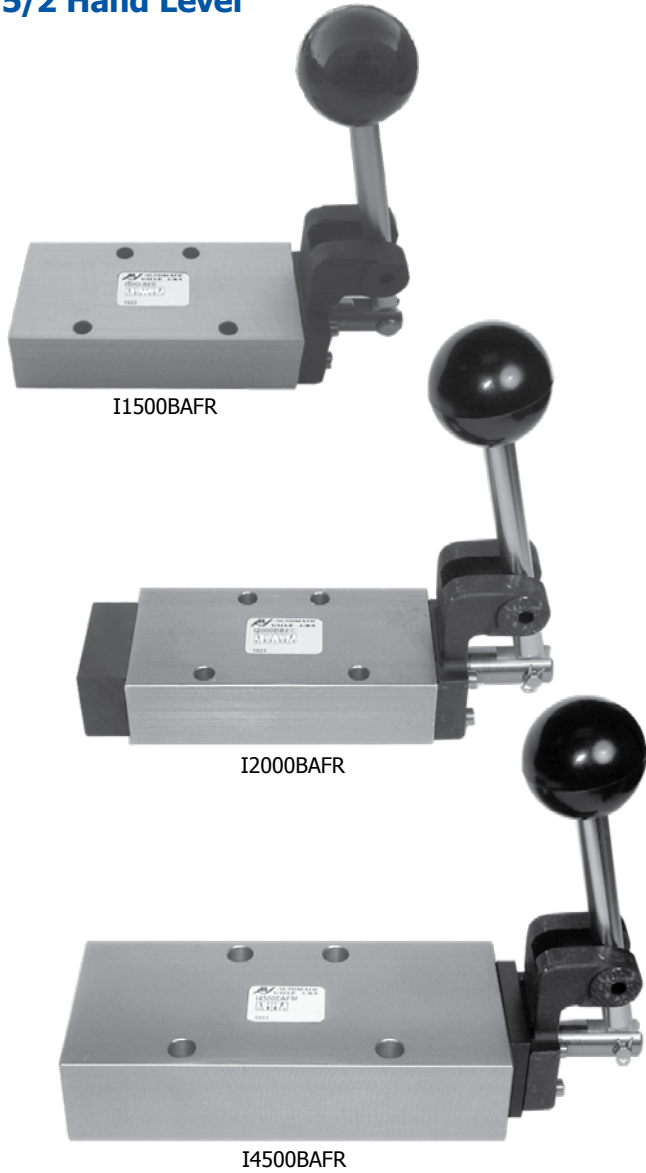

5/2 Palm Button

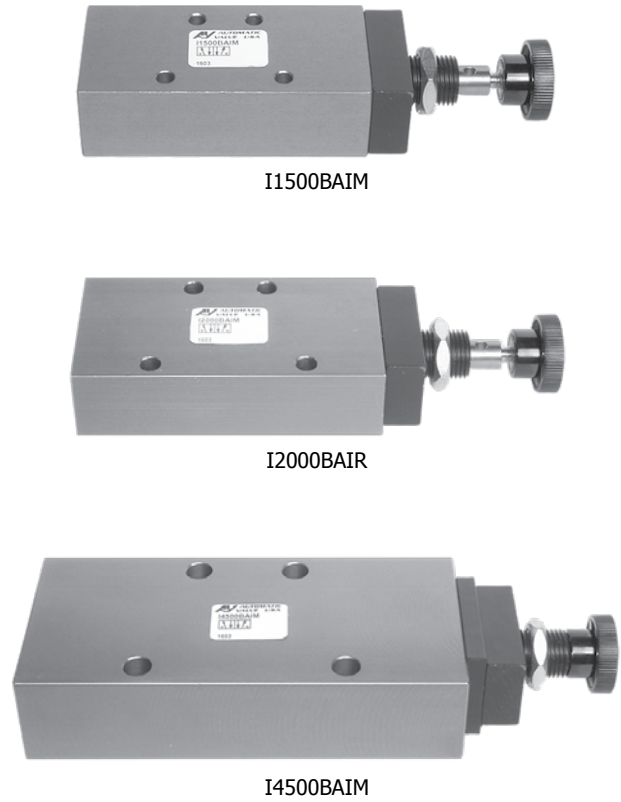

E

Model Numbers

Series	ISO Size	Port Location	Flow (5/2) l/min (Cv)	Operator	5/2 (4 Way 2 Position)		Materials		Weight Kg (lb)
					Detented	Spring Return	Body	Seal	
I15	1	Base	1480 (1.5)	Hand Lever	I1500BAFM	I1500BAFR	Aluminum	NBR	0,4 (0.9)
				Palm Button	I1500BAIM	I1500BAIR			
I20	2		1970 (2.0)	Hand Lever	I2000BAFM	I2000BAFR			
				Palm Button	I2000BAIM	I2000BAIR			
I45	3		4430 (4.5)	Hand Lever	I4500BAFM	I4500BAFR			
				Palm Button	I4500BAIM	I4500BAIR			



Dimensional Information

5/2 Hand Lever

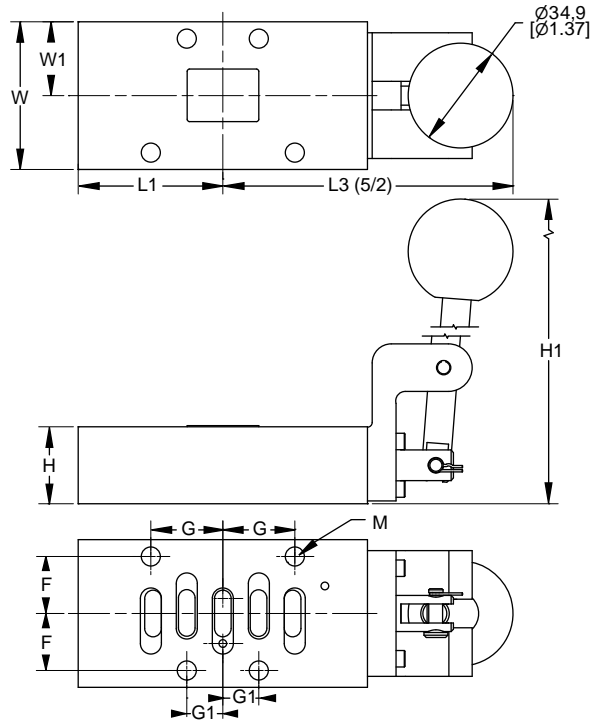

5/2 Palm Button

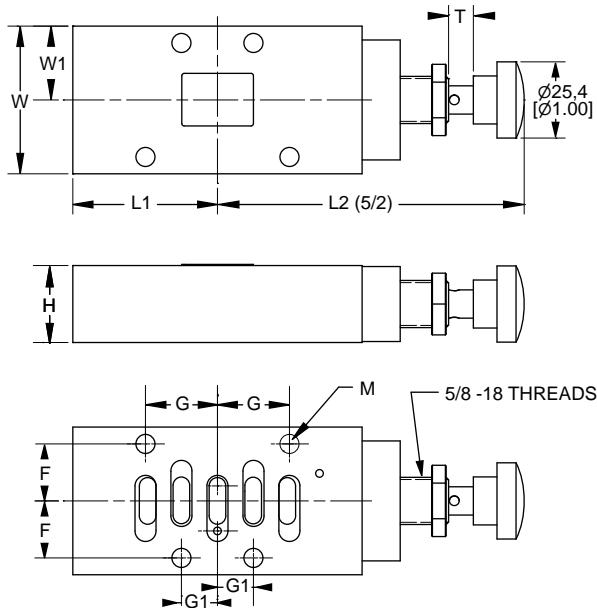

Series	ISO Size	F	G	G1	H	H1	L1	L2	L3	M	T	W	W1
I15	1	14,0 0.55	18,0 0.71	9,0 0.35	25,4 1.00	136 5.35	44,3 1.74	102 4.00	101 3.98	5,4 0.21	6,4 0.38	41,9 1.65	21,0 0.83
I20	2	19,0 0.75	24,0 0.95	12,0 0.47	25,4 1.00	136 5.35	48,2 1.90	106 4.16	105 4.14	6,4 0.25	9,5 0.38	49,2 1.94	24,6 0.97
I45	3	24,0 0.95	32,0 1.26	16,0 0.63	31,8 1.25	155 5.47	69,0 2.72	26,5 4.98	126 4.96	8,7 0.34	12,7 0.50	63,5 2.50	31,8 1.25

Units of Measure: Top - mm, Bottom - inches

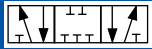

ISO Spool Valves Manual

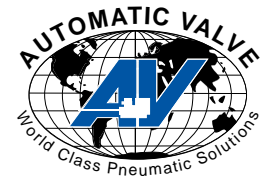

5/3 Hand Lever

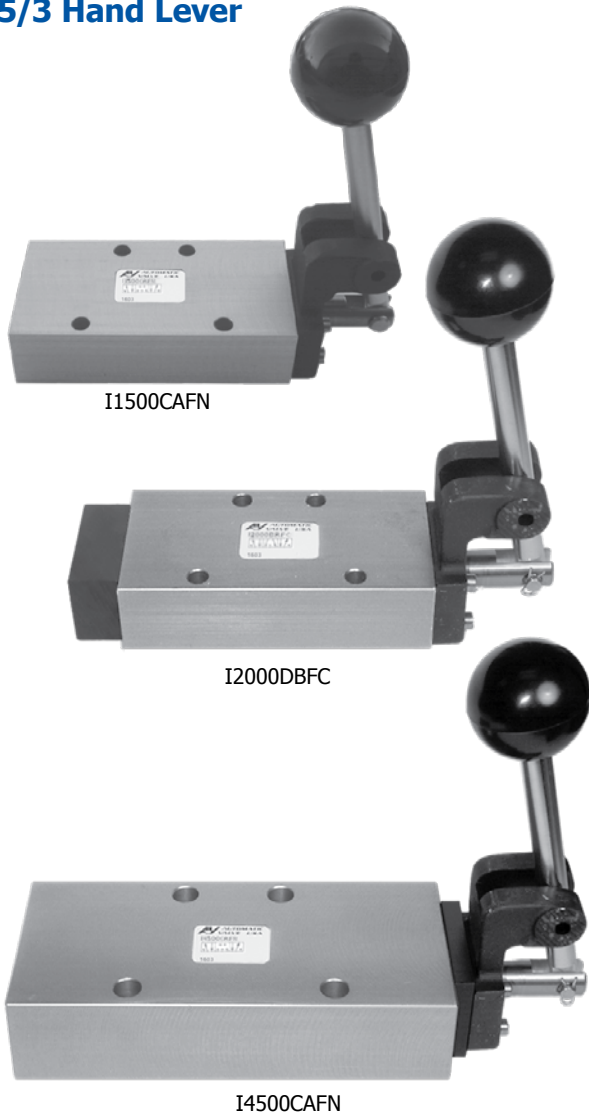

5/3 Palm Button

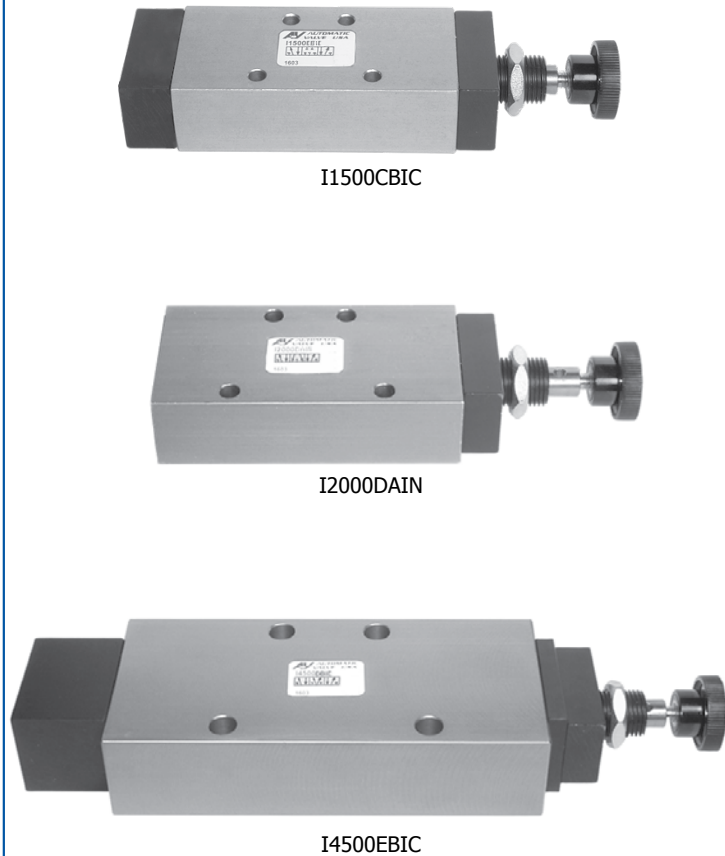

Model Numbers

Series	ISO Size	Flow (5/3) l/min (Cv)	Operator	5/3 (4 Way 3 Position)						Body Material	Seal Material	Weight kg (lb)
				Detented 5/3			Spring Center 5/3					
				Block	Exhaust	Pressure	Block	Exhaust	Pressure			
I15	1	1480 (1.5)	Hand Lever							Aluminum	NBR	0,4 (0,9)
			Palm Button									
I20	2	1970 (2.0)	Hand Lever									0,7 (1,5)
			Palm Button									
I45	3	4430 (4.5)	Hand Lever									0,9 (2,0)
			Palm Button									

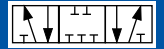

Dimensional Information

5/3 Hand Lever

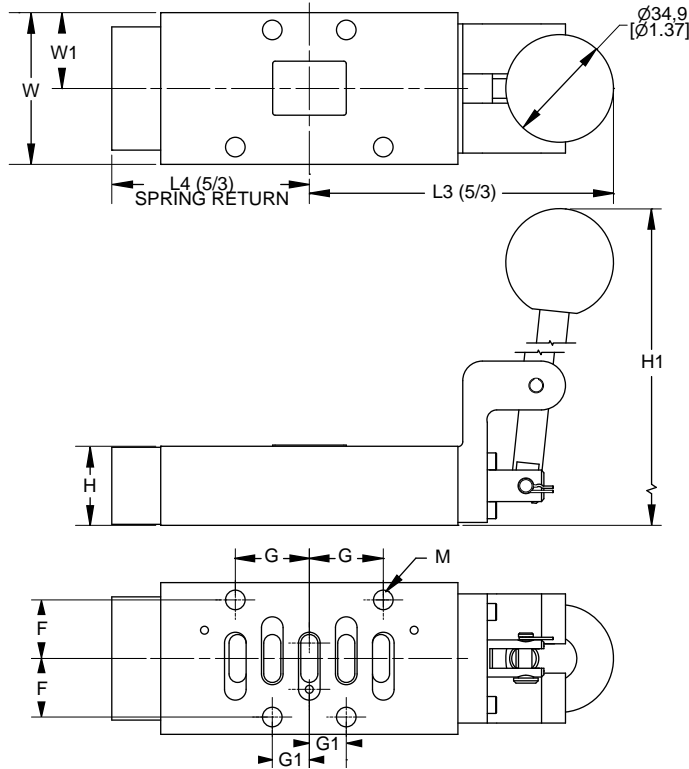

5/3 Palm Button

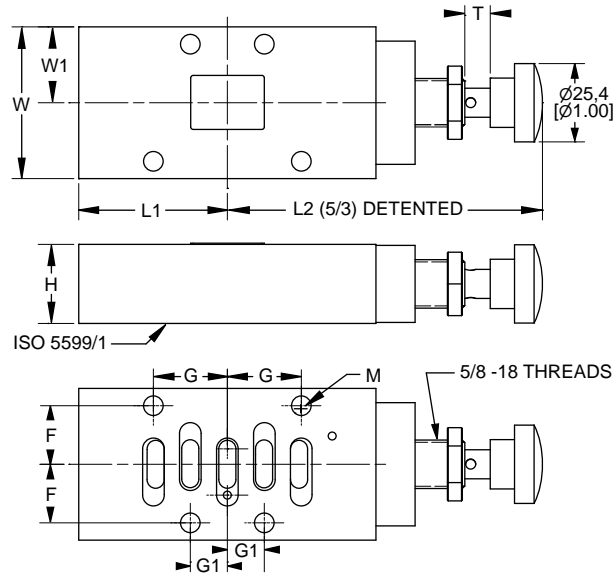

Series	ISO Size	F	G	G1	H	H1	L1	L2	L3	L4	W	W1
I15	1	14,0 0.55	18,0 0.71	9,0 0.35	25,4 1.00	136 5.35	44,3 1.74	102 4.00	101 3.98	60,1 2.37	41,9 1.65	21,0 0.83
I20	2	19,0 0.75	24,0 0.95	12,0 0.47	25,4 1.00	136 5.35	48,2 1.90	106 4.16	105 4.14	64,1 2.52	49,2 1.94	24,6 0.97
I45	3	24,0 0.95	32,0 1.26	16,0 0.63	31,8 1.25	155 5.47	69,0 2.72	26,5 4.98	126 4.96	99,2 3.91	63,5 2.50	31,8 1.25

Units of Measure: Top - mm, Bottom - inches

5/2



5/3

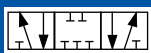

ISO Spool Valves Sub-Bases and Manifolds

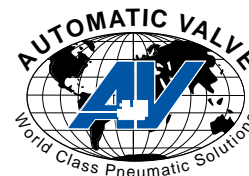

Sub-Base

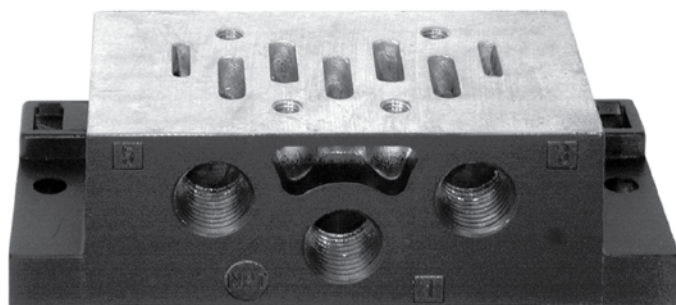

7107-501

Manifold (Bottom Ported Shown)

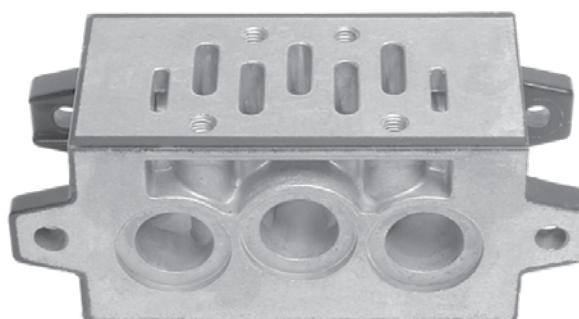

A7107-503

E

Model Numbers

Series	ISO Size	Sub-Base				Manifold					Manifold Accessories		
		Model Number*	Ports 2, 4	Ports 1, 3, 5	Wt Kg (lb)	Model Number*		Ports 2, 4	Ports 1, 3, 5	Wt Kg (lb)	Model Number*		
						Bottom	Side				End Plates	Blocking Disk	Blank Station Cover
I15	1	7107-501	1/4	1/4	0,5 (1.0)	A7107-503	A7108-008	1/4	3/8	0,68 (1.5)	7107-504	A7002-010	A7107-506
		7107-502	3/8	3/8									
I20	2	7112-501	3/8	3/8	0,5 (1.0)	A7113-046	A7113-046	3/8	3/8	0,68 (1.5)	-	A7112-505	A7112-506
		7112-502	1/2	1/2									
I45	3	7129-501	1/2	1/2	0,54 (1.2)	-	7130-021	1/2	1	0,91 (2.0)	7129-504	A7129-505	A7129-506
		7129-502	3/4	3/4									

* G Threads: Add the letter "W" after the model number to indicate G Threads

Dimensional Information

Sub-Bases

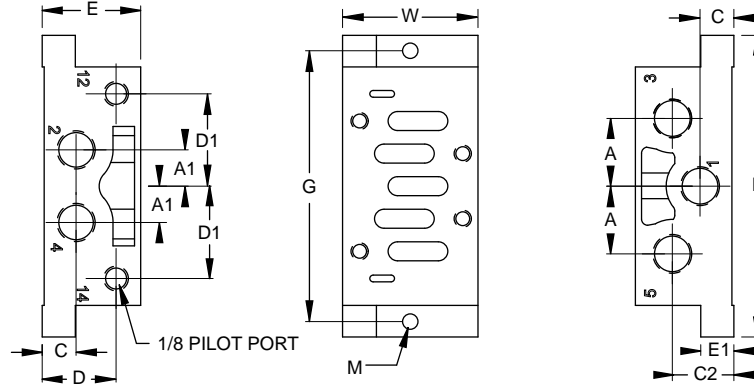

PORT SIZES:
See Model Number Chart
on previous page

Manifolds

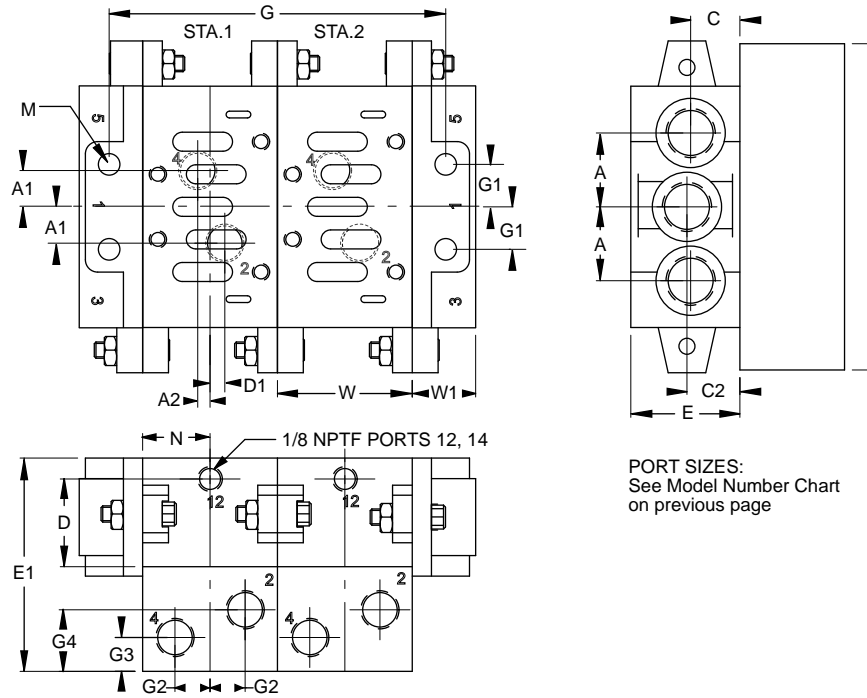

PORT SIZES:
See Model Number Chart
on previous page

	Series	ISO Size	A	A1	A2	C	C2	D	D1	E	E1	G	G1	G2	G3	G4	L	M	N	W	W1
Sub-Base	I15	1	21,5 0.85	12,0 0.47	-	10,5 0.41	21,5 0.85	23,5 0.93	29,0 1.10	32,0 1.30	10,0 0.39	98,0 3.90	-	-	-	-	110 4.30	5,6 0.22	-	48,0 1.90	-
	I20	2	28,0 1.10	15,0 0.59	-	14,0 0.55	25,9 1.02	30,0 1.18	37,0 1.46	40,0 1.57	13,0 0.51	112 4.41	-	-	-	-	124 4.88	7,0 0.26	-	57,0 2.24	-
	I45	3	34,0 1.30	16,0 0.63	-	17,0 0.67	17,0 0.67	22,0 0.87	45,0 1.80	32,0 1.30	18,0 0.71	136 5.40	-	-	-	-	149 5.90	7,0 0.26	-	71,0 2.80	-
Manifold	I15	1	24,0 0.94	13,0 0.51	1,5 0.06	21,0 0.83	24,0 0.94	37,0 1.47	7,5 0.30	46,0 1.80	81,0 3.20	108 4.30	14,0 0.55	11,0 0.43	12,0 0.47	25,0 0.98	110 4.30	7,0 0.27	21,5 0.85	43,0 1.69	22,0 0.87
	I20	2	35,5 1.40	17,8 0.70	14,3 0.56	27,4 1.08	27,4 1.08	42,8 1.68	14,3 0.56	52,3 2.06	-	118 4.63	27,9 1.10	13,5 0.53	12,2 0.48	12,2 0.48	133 5.25	7,1 0.28	27,9 1.10	55,9 2.20	-
	I45	3	48,2 1.90	19,0 0.75	6,0 0.24	30,4 1.20	33,0 1.30	45,9 1.81	7,8 0.31	55,9 2.20	99,0 3.90	172 6.80	25,4 1.00	18,0 0.71	17,0 0.67	27,9 1.10	190 7.50	11,9 0.47	35,5 1.40	71,1 2.80	30,5 1.20

Units of Measure: Top - mm, Bottom - inches

5/2 

5/3 

ISO Spool Valves Configuration Example

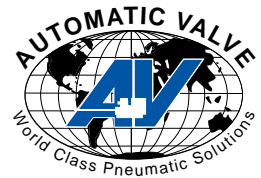

Valve With W-Solenoid Cap + Coil = Valve With Coil



I2000AAXR

+



NEMA 4x with DIN
43650 Form B
Connection

7019-9**

=



I2000AAXR-**



I2000AAXR

+



NEMA 4x with
18" Leads

7019-9**G

=



I2000AAXR-**G



I2000AAXR

+



NEMA 4x 1/2" Conduit
with 30" Leads

7019-9**C

=



I2000AAXR-**C



I2000AAXR

+



Explosion-Proof 1/2"
Conduit with 24" Leads

7019-9**Y

=



I2000AAXR-**Y



I2000AAXR

+



ATEX Explosion-Proof
with 39" Cable

7152-9**

=



I2000AAXR-**Z

E

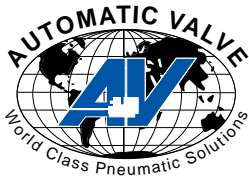

ISO Spool Valves Electrical Information

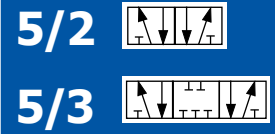

ISO Spool Valves

Part Numbers

Description	Operator Type	Instructions	Wt. Kg(lb)	Coil Part Number **=Voltage
Weather-Proof DIN 43650 Industrial Form B Connection NEMA 4X	X	Order coil separately (specify voltage code from below)	0,05 (0.12)	7019-9**
Weather-Proof 18" Leads NEMA 4X	X	Order coil separately (specify voltage code from below)	0,05 (0.12)	7019-9**G
Weather-Proof 1/2" Conduit with 30" Leads NEMA 4X	X	Order coil separately (specify voltage code from below)	0,05 (0.12)	7019-9**C 7019-9**CT (high temp 82°C max)
Explosion-Proof 1/2" Conduit with 24" Leads CSA & FM Approved CL. I; Zone1 ExmII T4; AExmII CL. I; Div.1; GR. A, B, C, D CL. II; GR. E, F, G CL. III T4 Ta=-20°C to +60°C NEMA 4, 4X, 7C, 7D, 9	X	Order coil separately (specify voltage code from below)	0,20 (0.44)	7019-9**Y
Intrinsically-Safe Strain Relief Ex ia CL. I; GR. A, B, C, D CL. II; GR. E, F, G CL. III; Div.1; T5	V	Coil and Connector included with valve (24VDC only)	0,21 (0.46)	A7106-374-DB
A7106-374 Must be Used with an Intrinsically-Safe Barrier For more information refer to "Intrinsic Safety" insert on Page D7.				
Explosion-Proof 3m Cable & Strain Relief Ex m II T5 PTB 03 ATEX2018 X Ex II 2 G EEx m II T5 Ex II 2 D IP65 T95°C	Z	Order coil separately (specify voltage code from below)	0,36 (0.78)	7152-9**

E

Voltage Codes (Lower wattage options available, consult factory)

** Code	Voltage +/-10%		Current (Amps)								Resistance (OHMS @ 25°C)				Power (AC=VA, DC=Watts)							
	Operator Type:		Inrush				Holding				X		V		Z		X		V		Z	
			NEMA		ATEX		NEMA		ATEX													
	NEMA 4	NEMA 7,9 & ATEX	4, 4x	7, 9	Exia	Exm	4, 4x	7, 9	Exia	Exm	4, 4x	7, 9	Exia	Exm	4, 4x	7, 9	Exia	Exm				
DA	24/50 24/60	-	.36	-	-	-	.24	-	-	-	32	-	-	-	6.9	-	-	-				
AA	120/50 120/60	120/60	.08	.10	-	.04	.05	.05	-	.03	840	530	-	1664	6.9	6.5	-	3.4				
AB	230/50 230/60	240/60	.04	.05	-	.02	.03	.03	-	.01	3310	2345	-	6730	6.4	6.8	-	3.3				
DA	12 VDC	12VDC	.38	.38	-	.27	.38	.38	-	.27	32	32	-	45	4.8	4.5	-	3.5				
DB	24 VDC	24VDC	.20	.19	.05	.14	.20	.19	.05	.14	121	128	275	177	4.8	4.5	1.6	3.5				
AB	125 VDC	-	.04	-	-	-	.04	-	-	-	3310	-	-	-	5.9	-	-	-				

Connectors (Not polarity dependent)

DIN 43650 Industrial Form B	Maximum Cable Diameter: 9mm (0.35")		Strain Relief with Light		1/2" Conduit without Cord	Molded with 6' Cord	Strain Relief with Light & 6' Cord	
Type	Strain Relief without Cord	100-240 AC 48-120 DC	6-48 AC/DC	100-240 AC 48-120 DC	6-48 AC/DC			
Part Number	7020-001	7020-AA	7020-DB	7039-001	7020-006	7094-006	7094-007	

5/2



5/3

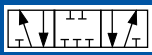

ISO Spool Valves Options

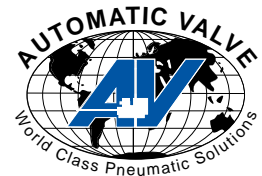

Options (Add the suffix to the end of the model number in alpha-numeric order)

Suffix	Option	Description
A	Fluoroelastomer Seals	For applications where fluid media or ambient conditions are not compatible with nitrile seals. <i>Note: Fluorocarbon seals do not increase the effective temperature range of the valve. For high temperature applications, consult the factory.</i>
B	External Pilot	For solenoid applications where the pressure to port one is less than 2 BAR (35 PSIG). See example below for field conversion.
		<p style="text-align: center;">Field Conversion</p> <ul style="list-style-type: none"> Remove solenoid and cap from the valve body. Rotate the gasket 180° so that the internal pilot hole in the valve body is covered by the gasket. Refasten the gasket, cap and solenoid to the valve body. Make sure the gasket completely covers the internal pilot hole before tightening the M3 screws. Torque to 1,02 N-m (9 in-lbs) ±10%. Remove the 1/8 NPTF pipe plug from the cap and make the external pilot connection.
C	Conduit Coil	Refer to the "Electrical Information" page in this section for details.
CT	Conduit Coil High Temperature	With 30" Leads. Refer to the "Electrical Information" page in this section for details.
D	Dustproof	For applications in extremely dusty and contaminated environments. Vent ports are plugged and spring pad breather vent is eliminated.
G	Coil With 18" Leads	Refer to the "Electrical Information" page in this section for details.
LL2	Lowest Watt Coil with Extended Turn-Locking Override	Power Consumption = 0.7 Watts. Solenoid cap provides an extended override that is turned to lock in the "on" position.
W	G Threads	All ports tapped to metric "G" standard. (Sub-bases and manifolds only)
Y	Explosion-Proof Coil (CSA, FM)	Refer to the "Electrical Information" page in this section for details.
Z	Explosion-Proof Coil (Atex, PTB)	Refer to the "Electrical Information" page in this section for details.
5	Extended Push Non-Locking Override	Solenoid cap provides an extended override that is pushed in to actuate and does not lock in the "on" position.

Valve must be disconnected from all air and electrical power sources before disassembly.

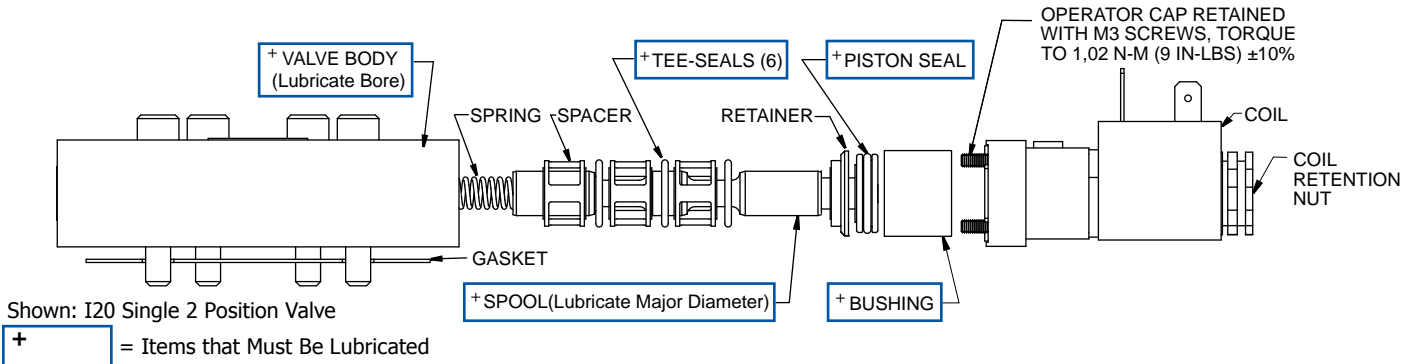

Service Kit Installation Instructions

1. Follow appropriate lock-out/tag-out procedures. Do not attempt to service a valve, if you are not familiar with lock-out/tag-out procedures.
2. Turn off electrical power to the valve.
3. Remove valve from all electrical and air power sources.
4. Ensure all stored air power is exhausted.
5. Remove coil by first removing coil retention nut.
6. Remove operator cap by first removing 4 socket head cap screws.
7. Remove existing serviceable components by "pushing" internal components gently out of the valve body.
8. Clean the spool with a clean cloth.
9. Discard the spring (Single Spring Return models only).
10. Lubricate the designated "+" items in the above assembly drawing with a thin film of lubricant - the item should look "WET" with no excess lubricant visible.
11. Replace components as shown above.
 - 11.1 Replace spring pad and spring (Single Spring Return models only).
 - 11.2 Alternate Tee-seals and spacers.
 - 11.3 Once all 6 Tee-seals are installed, replace the retainer, bushing and piston.
12. Orientate the operator cap by aligning the open end of the gasket with the pilot hole in the valve body.
13. Torque cap screws into body to 1,02 N-m (9 in-lbs) ±10%. Alternate tightening of the screws, so cap "squeezes" evenly onto the body.

E

Air Line Lubrication of Automatic Valve products is not required, but is recommended to maximize service life. Oils should be compatible with seal material, have an ISO 32 or lighter viscosity, and have an aniline point between 82°C (180°F) and 99°C (210°F). Refer to the Maintenance Section of this catalog for recommended lubricants.

Model Numbers: Service Kits

Series	Function			
	Single		Double	
	Model Number	Contents	Model Number	Contents
I15	K-I15-SGL K-I15-SGL-A (fluoroelastamer)	Tee-Seals (6), Gasket (1), Piston Seal (1), Spring (1)	K-I15-DBL K-I15-DBL-A (fluoroelastamer)	Tee-Seals (6), Gasket (1), Piston Seals (2)
	I20	K-I20-SGL K-I20-SGL-A (fluoroelastamer)	Tee-Seals (6), Gasket (1), Piston Seal (1), Spring (1)	K-I20-DBL K-I20-DBL-A (fluoroelastamer)
I45		K-I45-SGL K-I45-SGL-A (fluoroelastamer)	Tee-Seals (6), Gasket (1), Piston Seal (1), Spring (1)	K-I45-DBL K-I45-DBL-A (fluoroelastamer)

AV AUTOMATIC VALVE

F

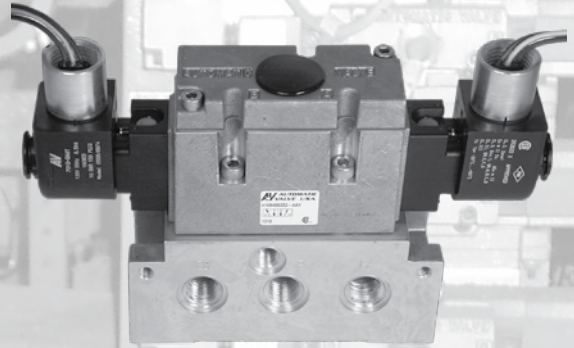
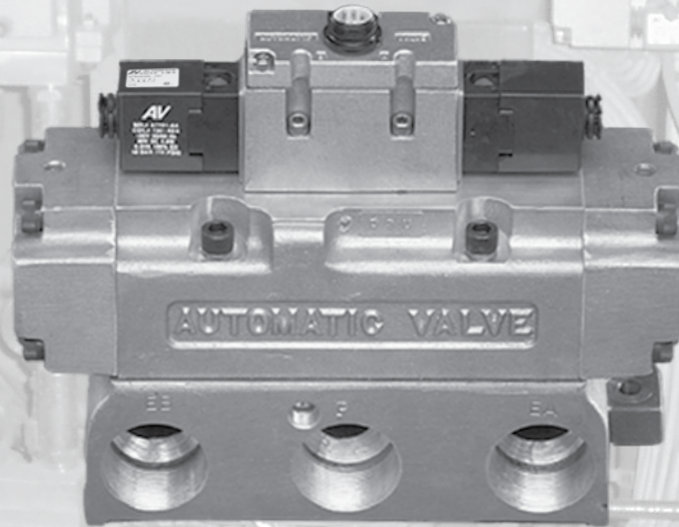
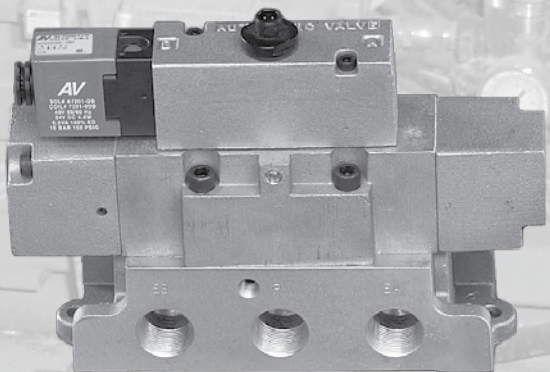

SAE Spool Valves

	Page
Design Features	F2
Configuration: Valve to Base	F2
Specifications	F3
Model Number	F3
Standard Solenoid	F4-F9
Air Pilot	F10-F15
Manual	F16-F18
Sub-Bases & Manifolds	F19-F22
Options	F23
Accessories	F23-F24
Electrical Information	F25
Service Information	F26-F29

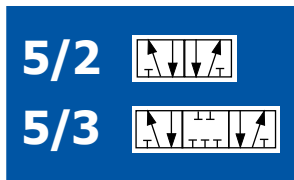

SAE Spool Valves

Design Features

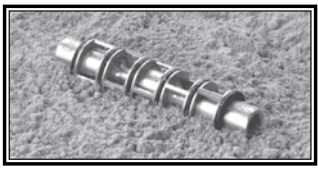
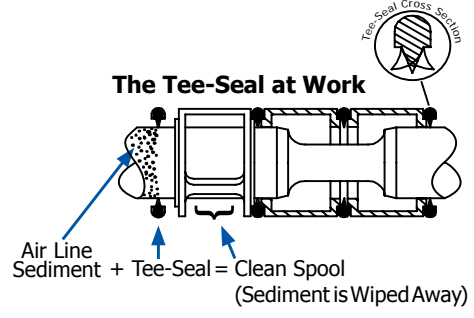

Valves

- Conforms to SAE J2051 specifications for series 125, 250 and 1000.
- Flow Range of 2 to 20 Cv.
- Complete range of bases and operators available.
- Do you have specific application needs? Consult the factory. We will build it for you.

Tapered Tee-Seal..... Eats Dirt

- Bidirectional tapered Tee-Seal eliminates sticking problems.
 - Flexes to clean spool
 - Mechanically Locked
 - No Spiral Twist
 - No Extrusion
 - Air Line Sediment is Wiped Away.
- Tested tough and proven reliable according to SAE specifications: Rust and water injected every 864,000 cycles for 20 million cycles.

Solenoid ... Guaranteed Against Burnout

- Three-way pilot uses full air line pressure to shift the valve.
- Pilot is internally supplied when the pressure at port one is 35 to 150 PSIG (240 to 1030 kPa).
- Coil is hermetically sealed as an integral watertight molded unit.
- Intrinsically-safe and explosion-proof versions available.
- Push Non-Locking Override is standard.

Products Certified To:

- CSA - (C22.2 and UL STD 429)
- Factory Mutual - Explosion Proof Environments
- ATEX - Explosion Proof Environments
- CE - EMF and Low Voltage Directives

F Configuration: Valve to Base

Description	Configuration	Model Number Prefix	Available Series
Valve Only		= 407	A04 (125) A06 (250) A20 (1000)
Valve + Sub-Base		= 409	A04 (125) A06 (250) A20 (1000)
Valve + Manifold (Bottom Cylinder Ports)		= 413	A04 (125) A06 (250)
Valve + Manifold (Bottom/Side Cylinder Ports)		= 416	A04 (125) A06 (250)

SAE Spool Valves Specs & Model Numbers

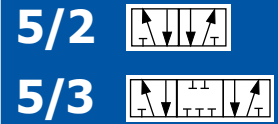

Specifications

Valve Operation		Valve Operation	
<p>A04 A06 A20</p>		<p>5/3 BLOCK Maintained Energized 12: Pressure from Port 1 to Port 2 Exhaust from Port 4 to Port 5 De-Energized: All ports Blocked Maintained Energized 14: Pressure from Port 1 to Port 4 Exhaust from Port 2 to Port 3</p>	
<p>5/2 SINGLE De-Energized: Pressure from Port 1 to Port 2 Exhaust from Port 4 to Port 5 Energized: Pressure from Port 1 to Port 4 Exhaust from Port 2 to Port 3</p>		<p>5/3 EXHAUST Maintained Energized 12: Pressure from Port 1 to Port 2 Exhaust from Port 4 to Port 5 De-Energized: Port 2 open to Port 3, Port 4 open to Port 5 Port 1 Blocked Maintained Energized 14: Pressure from Port 1 to Port 4 Exhaust from Port 2 to Port 3</p>	
<p>5/2 DOUBLE Momentarily Energized 12: Pressure from Port 1 to Port 2 Exhaust from Port 4 to Port 5 Momentarily Energized 14: Pressure from Port 1 to Port 4 Exhaust from Port 2 to Port 3</p>		<p>5/3 PRESSURE Maintained Energized 12: Pressure from Port 1 to Port 2 Exhaust from Port 4 to Port 5 De-Energized: Port 1 open to Ports 2 & 4; Ports 3 & 5 Blocked Maintained Energized 14: Pressure from Port 1 to Port 4 Exhaust from Port 2 to Port 3</p>	
Operating Temperatures	Solenoid Pilot Operated	Treated Buna-N Seals (Treated NBR, Standard)	Fluoroelastomer Seals (FPM (FKM), Option A)
	Standard	-18°C to +50°C (0°F to +123°F)	-18°C to +50°C (0°F to +123°F)
Operating Pressures	Solenoid Pilot Operated	Inlet Port	External Pilot Port
	Standard 2 Position	240 - 1030 kPa (35 - 150 PSIG)	-
	Standard 3 Position	345 - 1030 kPa (50 - 150PSIG)	-
	External Pilot (Option B)	Vacuum - 240 kPa (Vacuum - 35 PSIG)	240 - 1030 kPa (35 - 150 PSIG)
Filtration & Lubrication	Media - Air Or Inert Gas		
	Air Line Lubrication of Automatic Valve products is not required, but is recommended to maximize service life. Oils should be compatible with seal material, have an ISO 32 viscosity, and have an aniline range between 82°C (180°F) and 99°C (210°F). Filter to 50 microns or better. For temperatures below 40°F, air must be dry to prevent formation of ice. Refer to the Maintenance section of this catalog for recommended lubricants.		

Model Numbers

Series	Body Type	Function	Series		Operator 1	Center Operator	Operator 2	Voltage ¹	Options*
			#	Port Size					
A04 (125)	407 Valve Only	B 4 Way 2 Position	43	-	S3 Weather-Proof Solenoid	9D 3 Position Spring Center (Solenoid & Air Pilot)	S3 Weather-Proof Solenoid	-AA 110/50, 120/60	A Fluoroelastomer Seals (A04 & A06)
	409 Valve with Sub-Base	C 4 Way 3 Position Block	42	1/4	1A Air Pilot		1A Air Pilot	-AB 220/50, 240/60, 125VDC	B External Pilot Connection
	413 Valve with Manifold (Bottom Cylinder Ports)	D 4 Way 3 Position Exhaust	43	3/8	3B Hand Lever (A04 & A06)		1C 2 Position Air Return (A06)	-DA 22/50, 24/60, 12VDC	D Dustproof
	416 Valve with Manifold (Bottom-Side Cylinder Ports)	E 4 Way 3 Position Pressure	67	-			7A 2 Position Detent	-DB 24VDC	Y Explosion-Proof Coil (CSA,FM)
A06 (250)	407 Valve Only		65	1/2		7B 3 Position Detent	-DE 125VDC (Y coil)	0 GM - 5 Pin Micro	
	409 Valve with Sub-Base		67	3/4		9A 2 Position Spring Return		1 Ford - 5 Pin Micro	
	413 Valve with Manifold (Bottom Cylinder Ports)		60	1		9B 3 Position Spring Center (For Manual Operators)		2 Chrysler - 5 Pin Micro AC/DC	
	416 Valve with Manifold (Bottom-Side Cylinder Ports)		65	1/2				3 GM - 5 Pin Mini	
A20 (1000)	407 Valve Only		67	3/4				4 Ford - 5 Pin Mini	
	409 Valve with Sub-Base		12	-				5 Chrysler - 5 Pin Mini	
			12	1 1/4				6 GM - 4 Pin Micro DC	
			15	1 1/2				7 Ford - 4 Pin Micro DC	

* Not all Options are available for all models. Refer to "Options" at the end of this Section for additional information.
¹ Consult the Factory for additional voltages.

5/2



5/3

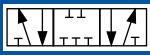

SAE Spool Valves Standard Solenoid

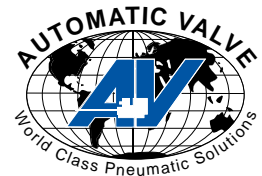

A04 (125 Series) - Single Weather-Proof (W-P)

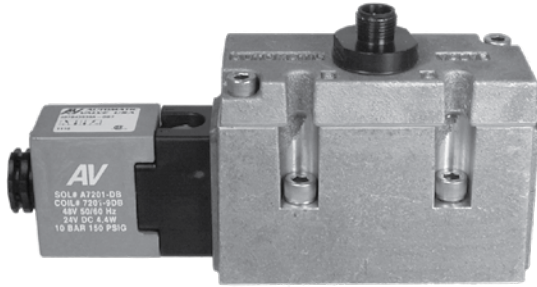

407B43S39A-DB7

Explosion-Proof

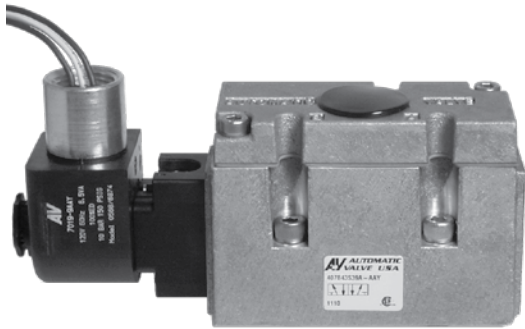

407B43S39A-AA7

A04 (125 Series) - Double Weather-Proof (W-P)

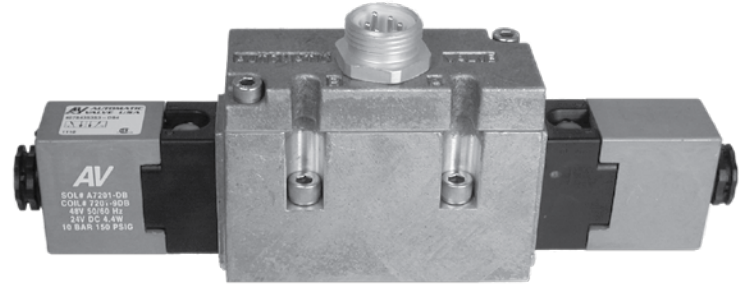

407B43S3S3-DB4

Explosion-Proof



407B43S3S3-AA7

Model Numbers

Body Type	Port Loc'n	Port Size	Flow l/min (Cv)	Operator ¹	5/2		5/3			Materials	Weight Kg (lb)
					Single	Double	Block	Exhaust	Pressure		
Valve Only	-	-	1841(1.9)	W-P	407B43S39A-**	407B43S3S3-**	407C43S39DS3-**	407D43S39DS3-**	407E43S39DS3-**	Seal =NBR Body=Aluminum	2,0 (4.5)
				E-P	407B43S39A-**Y	407B43S3S3-**Y	407C43S39DS3-**Y	407D43S39DS3-**Y	407E43S39DS3-**Y		
Valve + Sub-Base	1/4	5/3	2360(2.4)	W-P	409B42S39A-**	409B42S3S3-**	409C42S39DS3-**	409D42S39DS3-**	409E42S39DS3-**		2,4 (5.4)
				E-P	409B42S39A-**Y	409B42S3S3-**Y	409C42S39DS3-**Y	409D42S39DS3-**Y	409E42S39DS3-**Y		
Valve + Manifold (Bottom Cyl Ports)	3/8	5/2	2360(2.4)	W-P	413B43S39A-**	413B43S3S3-**	413C43S39DS3-**	413D43S39DS3-**	413E43S39DS3-**	2,5 (5.5)	
				E-P	413B43S39A-**Y	413B43S3S3-**Y	413C43S39DS3-**Y	413D43S39DS3-**Y	413E43S39DS3-**Y		
Valve + Manifold (Bottom/Side Cyl Ports)	3/8	5/2	2360(2.4)	W-P	416B43S39A-**	416B43S3S3-**	416C43S39DS3-**	416D43S39DS3-**	416E43S39DS3-**	2,7 (5.9)	
				E-P	416B43S39A-**Y	416B43S3S3-**Y	416C43S39DS3-**Y	416D43S39DS3-**Y	416E43S39DS3-**Y		

** = Coil Voltage Code. Coils also sold separately. Refer to "Electrical Information" at the end of this Section for additional information.

¹ W-P = Weather-Proof; E-P = Explosion-Proof

Dimensional Information

A04 (125 Series) - Single

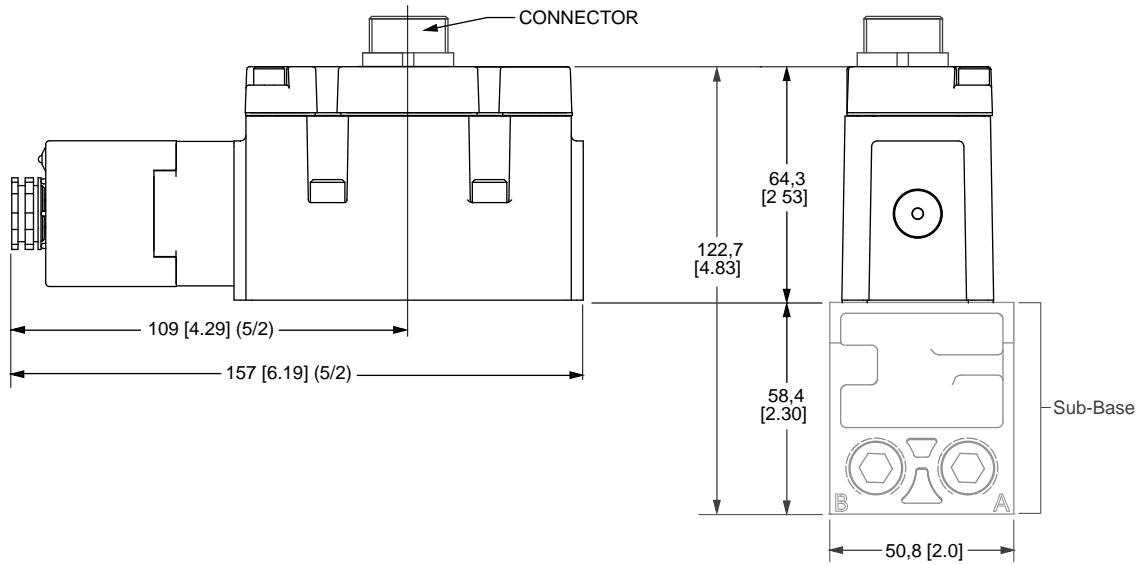

A04 (125 Series) - Double

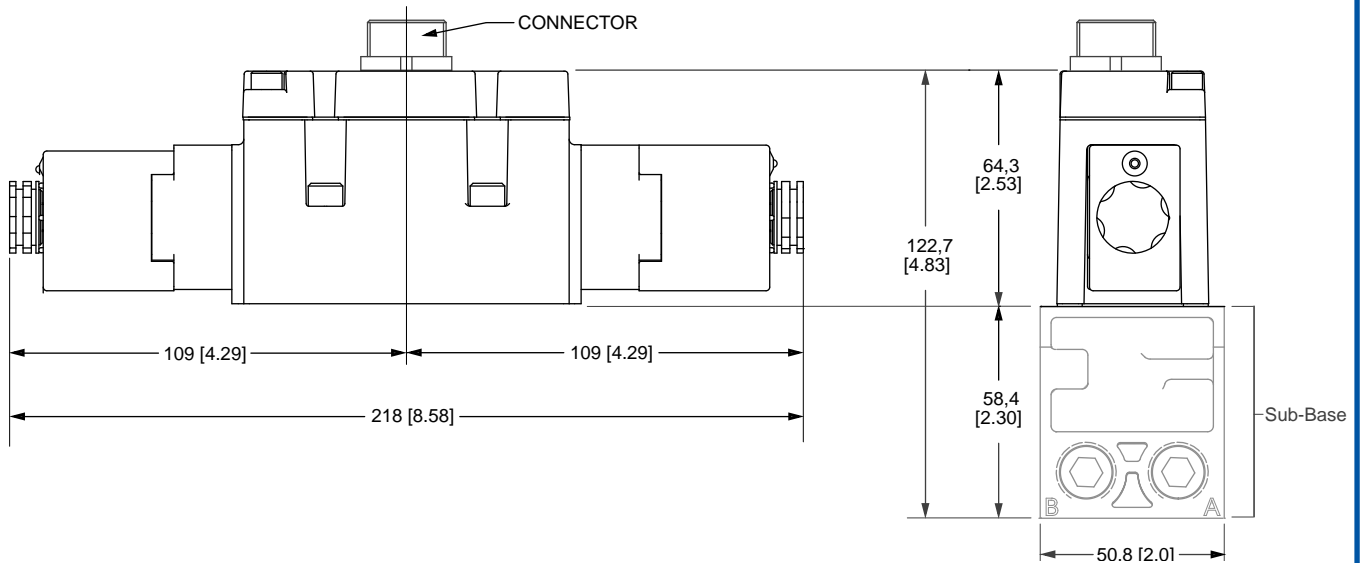

Units of Measure: Top - mm, Bottom - inches

5/2



5/3

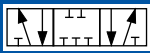

SAE Spool Valves Standard Solenoid

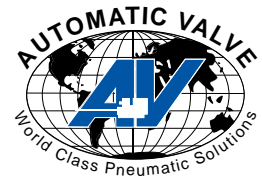

A06 (250 Series) - Single Weather-Proof (W-P)

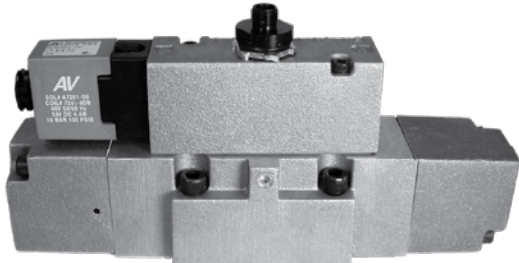

407B67S31C-DB7

Explosion-Proof

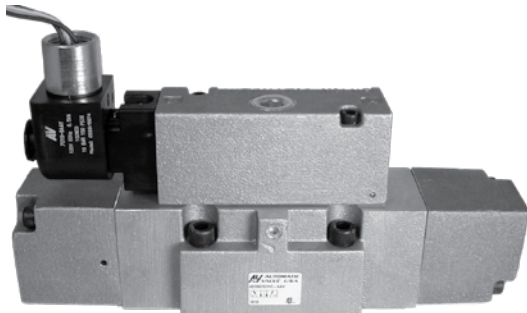

407B67S39A-AAV

A06 (250 Series) - Double Weather-Proof (W-P)

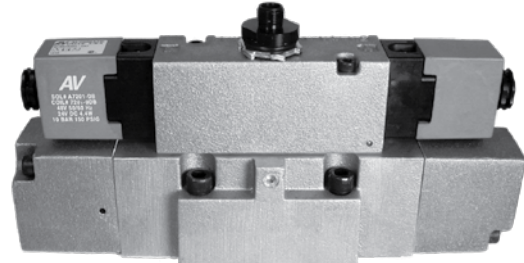

407B67S3S3-DB7

Explosion-Proof

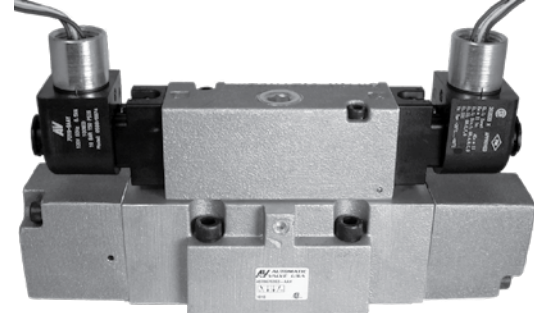

407B67S3S3-AAV

Model Numbers

Body Type	Port Loc'n	Port Size	Flow l/min (Cv)	Operator ¹	5/2		5/3			Materials	Weight Kg (lb)
					Single	Double	Block	Exhaust	Pressure		
Valve Only	-	-	-	W-P	407B67S39A-**	407B67S3S3-**	407C67S39DS3-**	407D67S39DS3-**	407E67S39DS3-**	Body=Aluminum Seal+NBR	3,7 (8.3)
				E-P	407B67S39A-**Y	407B67S3S3-**Y	407C67S39DS3-**Y	407D67S39DS3-**Y	407E67S39DS3-**Y		
Valve + Sub-Base	Base	1/2	5/3 Flow: 6599 (6.7)	W-P	409B65S39A-**	409B65S3S3-**	409C65S39DS3-**	409D65S39DS3-**	409E65S39DS3-**	5,0 (11.0)	
				E-P	409B65S39A-**Y	409B65S3S3-**Y	409C65S39DS3-**Y	409D65S39DS3-**Y	409E65S39DS3-**Y		
		3/4		W-P	409B67S39A-**	409B67S3S3-**	409C67S39DS3-**	409D67S39DS3-**	409E67S39DS3-**		
				E-P	409B67S39A-**Y	409B67S3S3-**Y	409C67S39DS3-**Y	409D67S39DS3-**Y	409E67S39DS3-**Y		
		1		W-P	409B60S39A-**	409B60S3S3-**	409C60S39DS3-**	409D60S39DS3-**	409E60S39DS3-**		
				E-P	409B60S39A-**Y	409B60S3S3-**Y	409C60S39DS3-**Y	409D60S39DS3-**Y	409E60S39DS3-**Y		
Valve + Manifold (Bottom Cyl Ports)	1/2	5/2 Flow: 8460 (8.6)	W-P	413B65S39A-**	413B65S3S3-**	413C65S39DS3-**	413D65S39DS3-**	413E65S39DS3-**	5,0 (11.0)		
			E-P	413B65S39A-**Y	413B65S3S3-**Y	413C65S39DS3-**Y	413D65S39DS3-**Y	413E65S39DS3-**Y			
	3/4		W-P	413B67S39A-**	413B67S3S3-**	413C67S39DS3-**	413D67S39DS3-**	413E67S39DS3-**			
			E-P	413B67S39A-**Y	413B67S3S3-**Y	413C67S39DS3-**Y	413D67S39DS3-**Y	413E67S39DS3-**Y			
Valve + Manifold (Bottom/Side Cyl Ports)	1/2	5/2 Flow: 8460 (8.6)	W-P	416B65S39A-**	416B65S3S3-**	416C65S39DS3-**	416D65S39DS3-**	416E65S39DS3-**	4,5 (10.1)		
			E-P	416B65S39A-**Y	416B65S3S3-**Y	416C65S39DS3-**Y	416D65S39DS3-**Y	416E65S39DS3-**Y			
	3/4		W-P	416B67S39A-**	416B67S3S3-**	416C67S39DS3-**	416D67S39DS3-**	416E67S39DS3-**			
			E-P	416B67S39A-**Y	416B67S3S3-**Y	416C67S39DS3-**Y	416D67S39DS3-**Y	416E67S39DS3-**Y			

** = Coil Voltage Code. Coils also sold separately. Refer to "Electrical Information" at the end of this Section for additional information.

¹ W-P = Weather-Proof; E-P = Explosion-Proof

Dimensional Information

A06 (250 Series) - Single

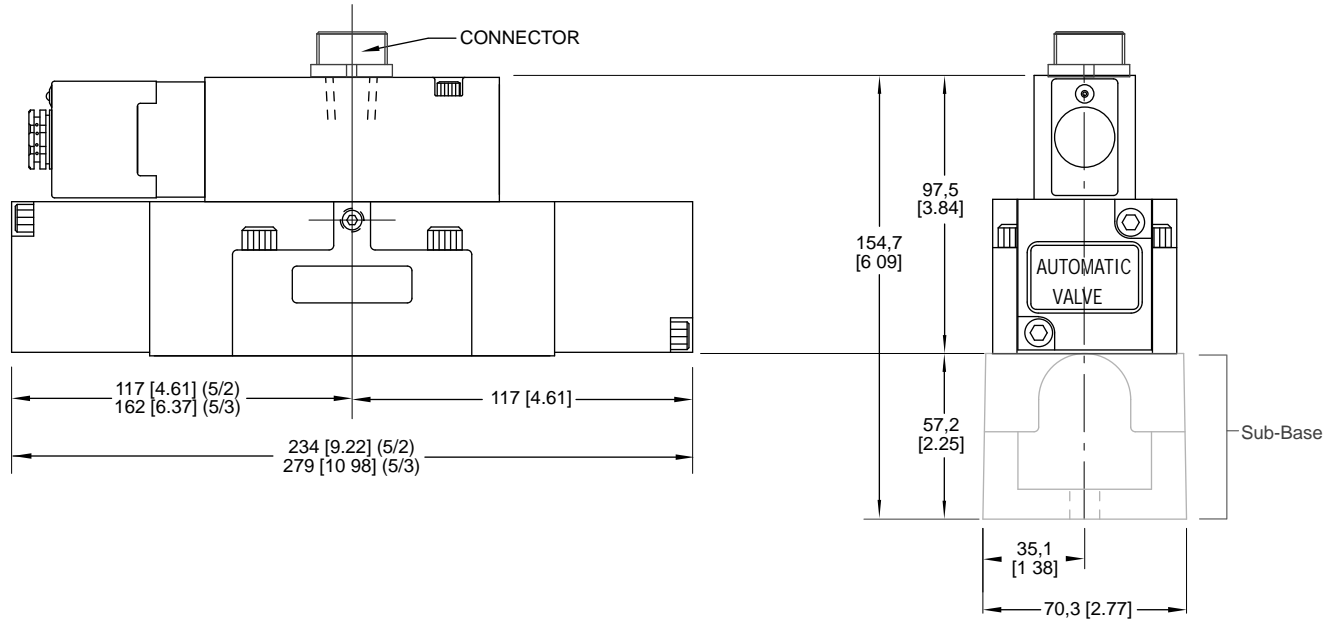

A06 (250 Series) - Double

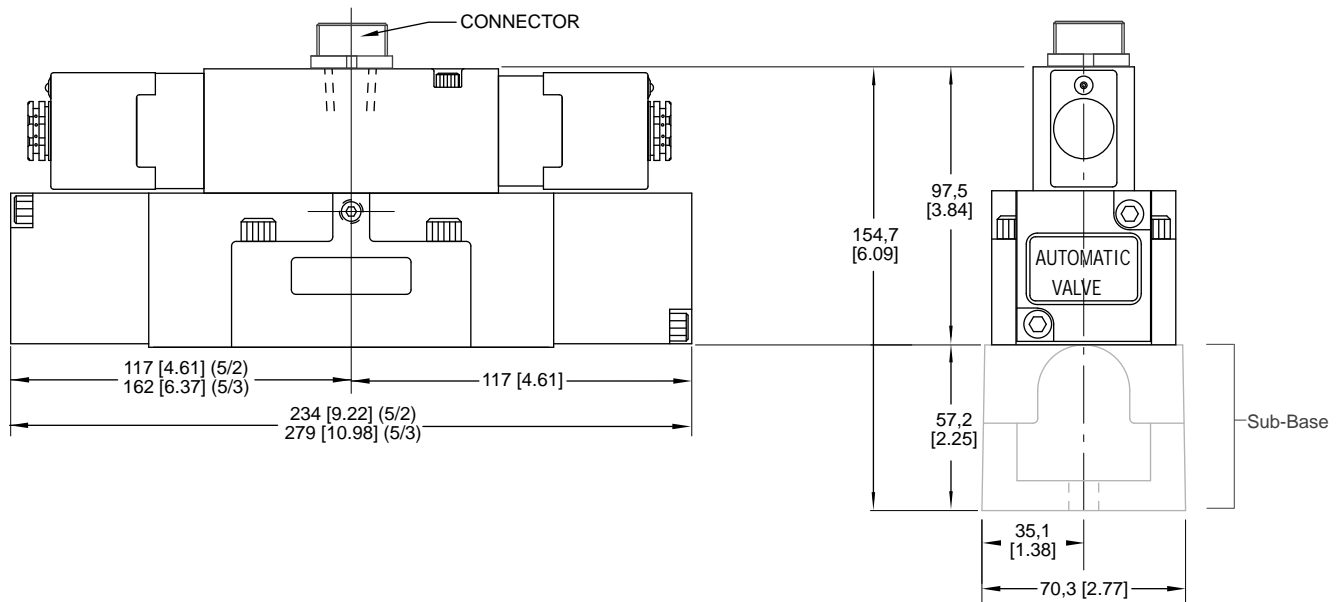

Units of Measure: Top - mm, Bottom - inches

5/2



5/3

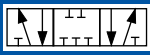

SAE Spool Valves Standard Solenoid

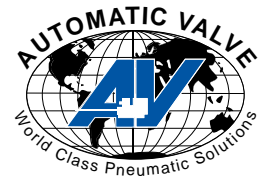

A20 (1000 Series) - Single

Weather-Proof (W-P)

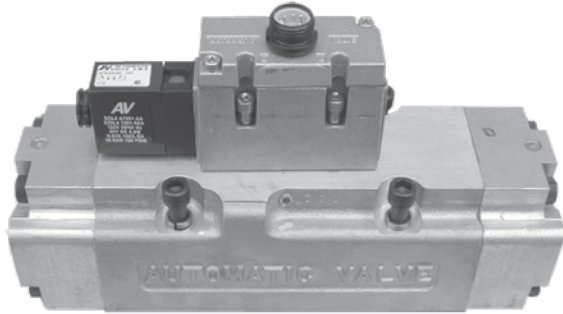

407B12S39A-AA4

Explosion-Proof

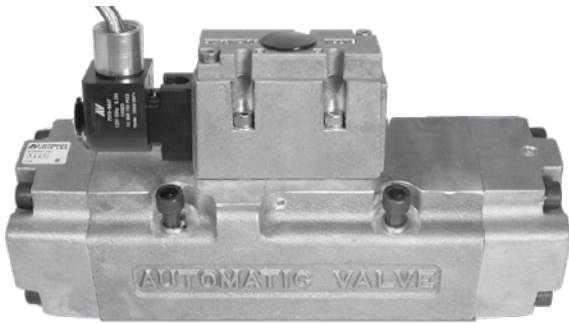

407B12S39A-AA4

A20 (1000 Series) - Double

Weather-Proof (W-P)

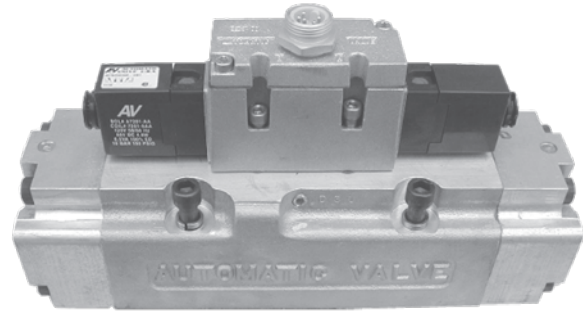

407B12S3S3-AA4

Explosion-Proof

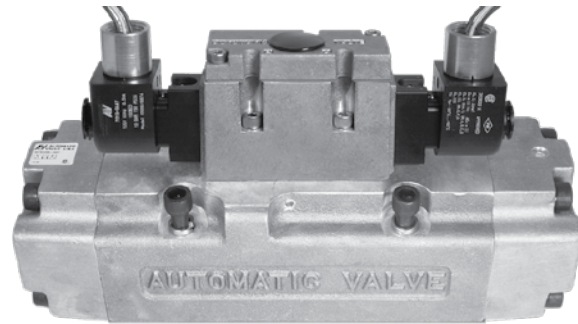

407B12S3S3-AA4

F

Model Numbers

Body Type	Port Loc'n	Port Size	Flow l/min (Cv)	Operator ¹	5/2		5/3			Materials	Weight kg (lb)
					Single	Double	Block	Exhaust	Pressure		
Valve Only	-	-	5/2 Flow: 22,340 (17.7)	W-P	407B12S39A-**-**	407B12S3S3-**-**	407C12S39DS3-**-**	407D12S39DS3-**-**	407E12S39DS3-**-**	Seal+NBR	8,7 (19.4)
				E-P	407B12S39A-**-**Y	407B12S3S3-**-**Y	407C12S39DS3-**-**Y	407D12S39DS3-**-**Y	407E12S39DS3-**-**Y		
Valve + Sub-Base	Base	1	5/3 Flow: 22,340 (22.7)	W-P	409B10S39A-**-**	409B10S3S3-**-**	409C10S39DS3-**-**	409D10S39DS3-**-**	409E10S39DS3-**-**	Body=Aluminum	12,0 (26.7)
				E-P	409B10S39A-**-**Y	409B10S3S3-**-**Y	409C10S39DS3-**-**Y	409D10S39DS3-**-**Y	409E10S39DS3-**-**Y		
	11/4	W-P		409B12S39A-**-**	409B12S3S3-**-**	409C12S39DS3-**-**	409D12S39DS3-**-**	409E12S39DS3-**-**			
		E-P		409B12S39A-**-**Y	409B12S3S3-**-**Y	409C12S39DS3-**-**Y	409D12S39DS3-**-**Y	409E12S39DS3-**-**Y			
	11/2	W-P		409B15S39A-**-**	409B15S3S3-**-**	409C15S39DS3-**-**	409D15S39DS3-**-**	409E15S39DS3-**-**			
		E-P		409B15S39A-**-**Y	409B15S3S3-**-**Y	409C15S39DS3-**-**Y	409D15S39DS3-**-**Y	409E15S39DS3-**-**Y			

** = Coil Voltage Code. Coils also sold separately. Refer to "Electrical Information" at the end of this Section for additional information.

¹ W-P = Weather-Proof; E-P = Explosion-Proof

Dimensional Information

A20 (1000 Series) - Single

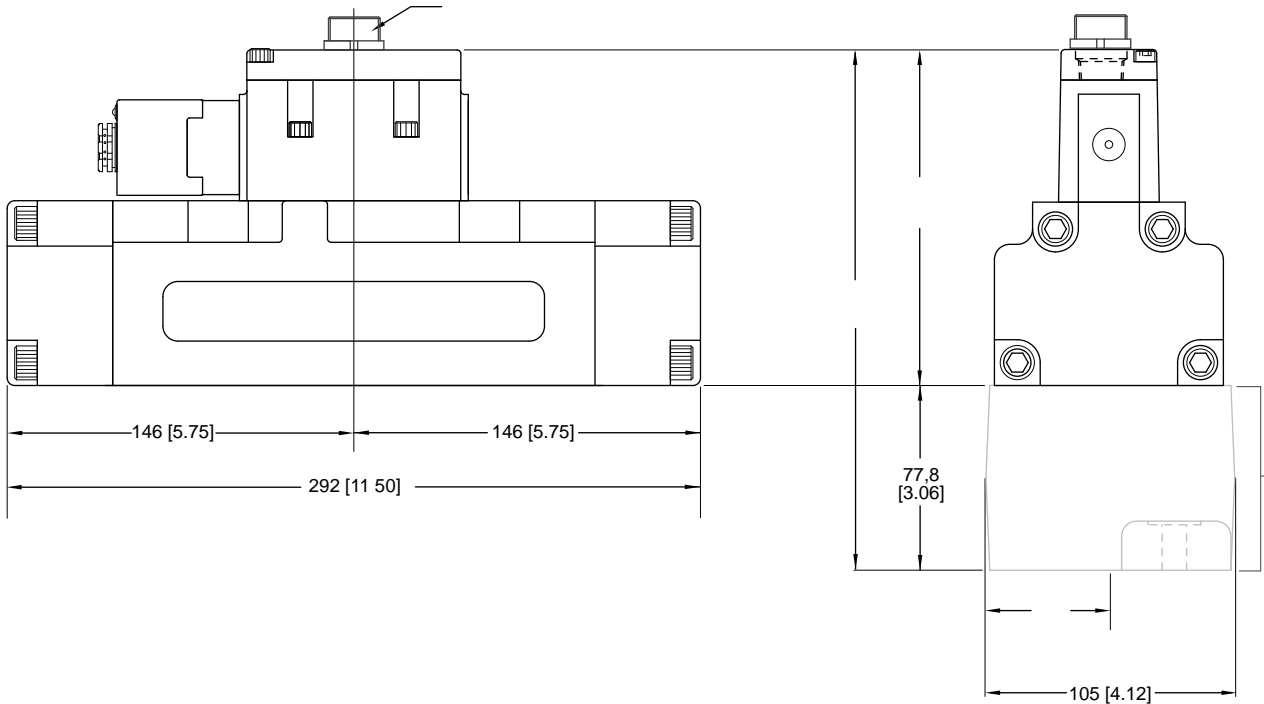

A20 (1000 Series) - Double

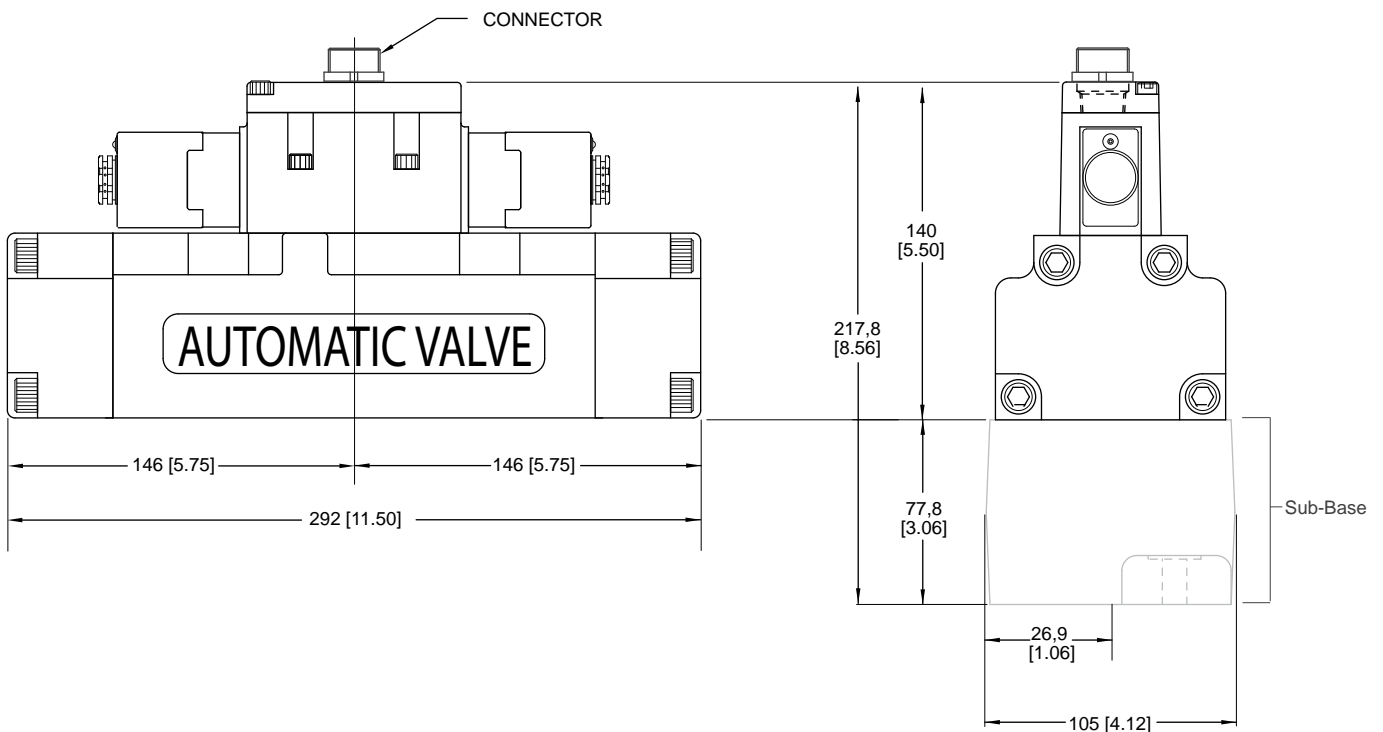

Units of Measure: Top - mm, Bottom - inches

5/2



5/3

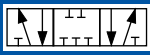

SAE Spool Valves Air Pilot

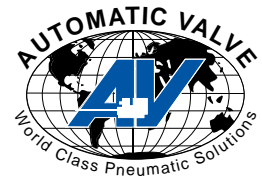

A04 (125 Series) - Single

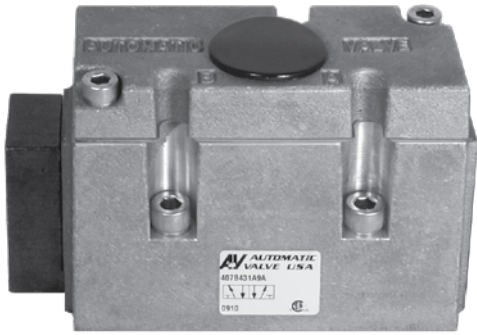

407B431A9A

A04 (125 Series) - Double

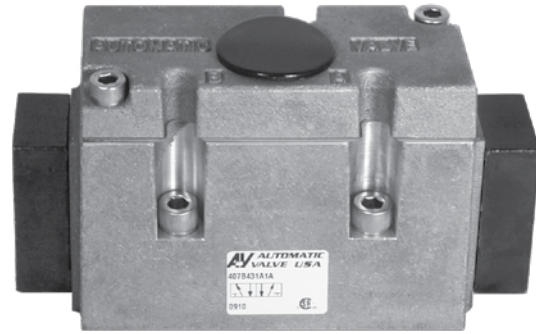

407B431A1A

Model Numbers

Body Type	Port Loc'n	Port Size	Flow l/min (Cv)	5/2		5/3			Materials	Weight kg (lb)
				Single	Double	Block	Exhaust	Pressure		
Valve Only	-	-	5/3 Flow: 1841 (1.9)	407B431A9A	407B431A1A	407C431A9D1A	407D431A9D1A	407E431A9D1A	Body=Aluminum Seal = NBR	1.0 (2.3)
Valve + Sub-Base	1/4	1/4	5/3 Flow: 2360 (2.4)	409B421A9A	409B421A1A	409C421A9D1A	409D421A9D1A	409E421A9D1A		1.4 (3.2)
Valve + Manifold (Bottom Cyl Ports)	3/8	3/8	5/2 Flow: 2360 (2.4)	413B431A9A	413B431A1A	413C431A9D1A	413D431A9D1A	413E431A9D1A		1.5 (3.3)
Valve + Manifold (Bottom/Side Cyl Ports)	3/8	3/8	5/2 Flow: 2360 (2.4)	416B431A9A	416B431A1A	416C431A9D1A	416D431A9D1A	416E431A9D1A		1.7 (3.7)

Dimensional Information

A04 (125 Series) - Single

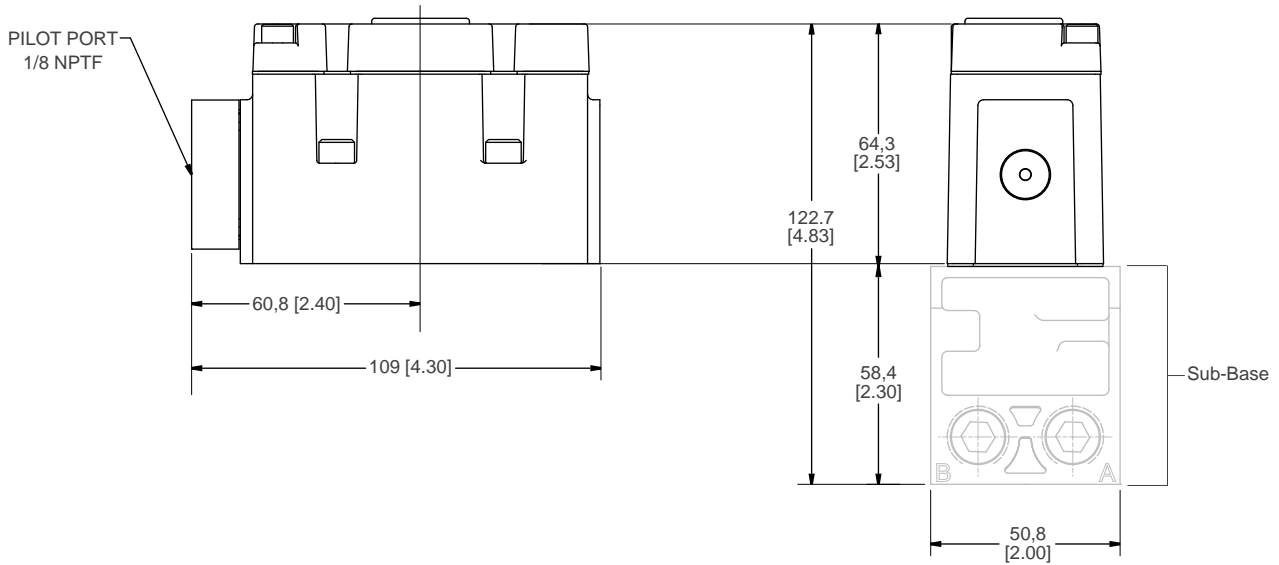

A04 (125 Series) - Double

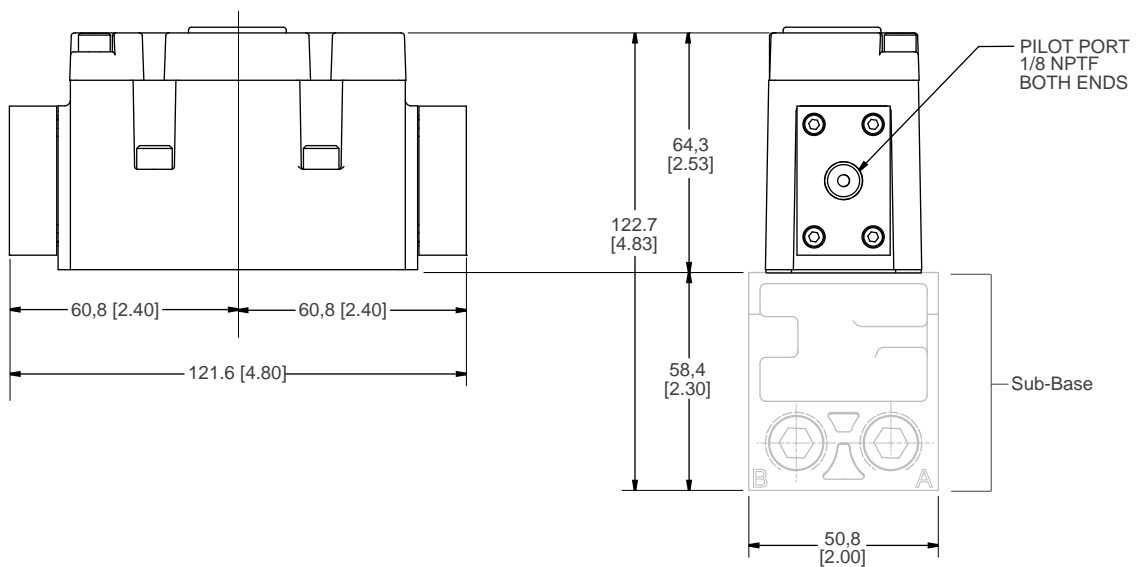

5/2



5/3

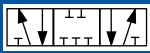

SAE Spool Valves Air Pilot

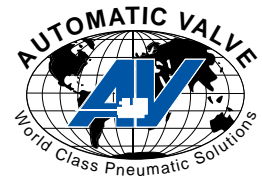

A06 (250 Series) - Single

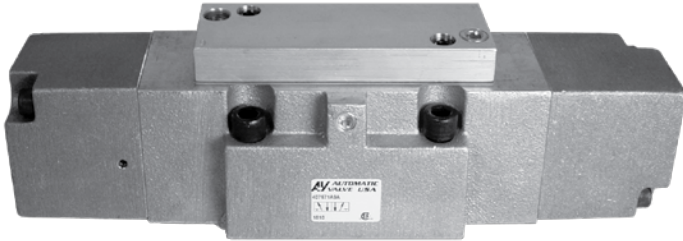

407B671A9A

A06 (250 Series) - Double

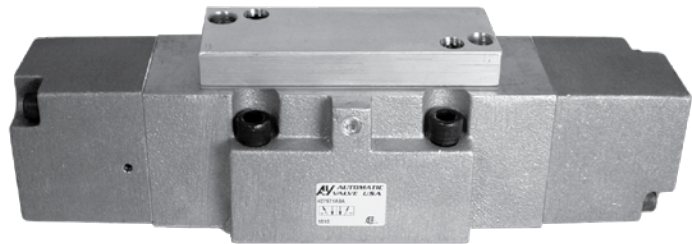

407B671A1A

Model Numbers

Body Type	Port Loc'n	Port Size	Flow l/min (Cv)	5/2		5/3			Materials	Weight Kg (lb)
				Single	Double	Block	Exhaust	Pressure		
Valve Only		-		407B671A9A	407B671A1A	407C671A9D1A	407D671A9D1A	407E671A9D1A	Body=Aluminum Seal = NBR	3,5 (7.8)
Valve + Sub-Base	Base	1/2	5/3 Flow: 6599 (6.7)	409B651A9A	409B651A1A	409C651A9D1A	409D651A9D1A	409E651A9D1A	Body=Aluminum Seal = NBR	4,7 (10.5)
		3/4	409B671A9A	409B671A1A	409C671A9D1A	409D671A9D1A	409E671A9D1A			
		1	409B601A9A	409B601A1A	409C601A9D1A	409D601A9D1A	409E601A9D1A			
Valve + Manifold (Bottom Cyl Ports)	Base	1/2	5/2 Flow: 8460 (8.6)	413B651A9A	413B651A1A	413C651A9D1A	413D651A9D1A	413E651A9D1A	Body=Aluminum Seal = NBR	4,3 (9.6)
		3/4	413B671A9A	413B671A1A	413C671A9D1A	413D671A9D1A	413E671A9D1A			
Valve + Manifold (Bottom/Side Cyl Ports)	Base	1/2	5/2 Flow: 8460 (8.6)	416B651A9A	416B651A1A	416C651A9D1A	416D651A9D1A	416E651A9D1A	Body=Aluminum Seal = NBR	4,3 (9.6)
		3/4	416B671A9A	416B671A1A	416C671A9D1A	416D671A9D1A	416E671A9D1A			

Dimensional Information

A06 (250 Series) - Single

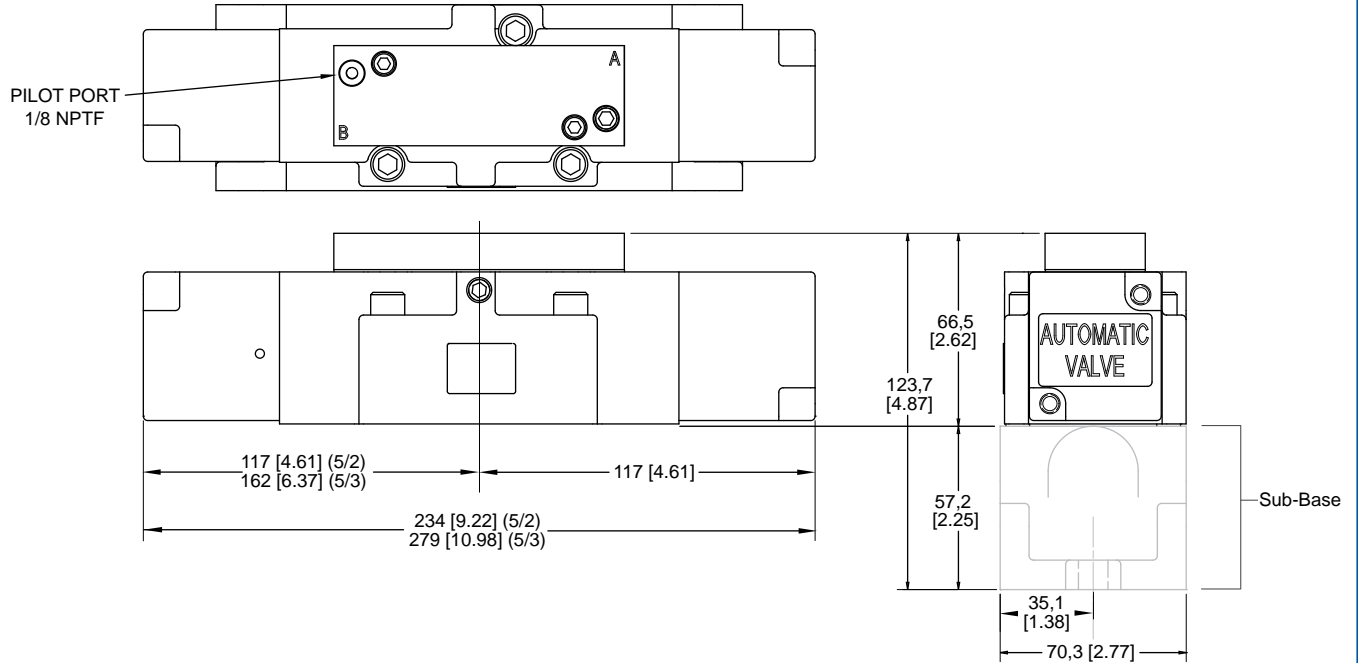

A06 (250 Series) - Double

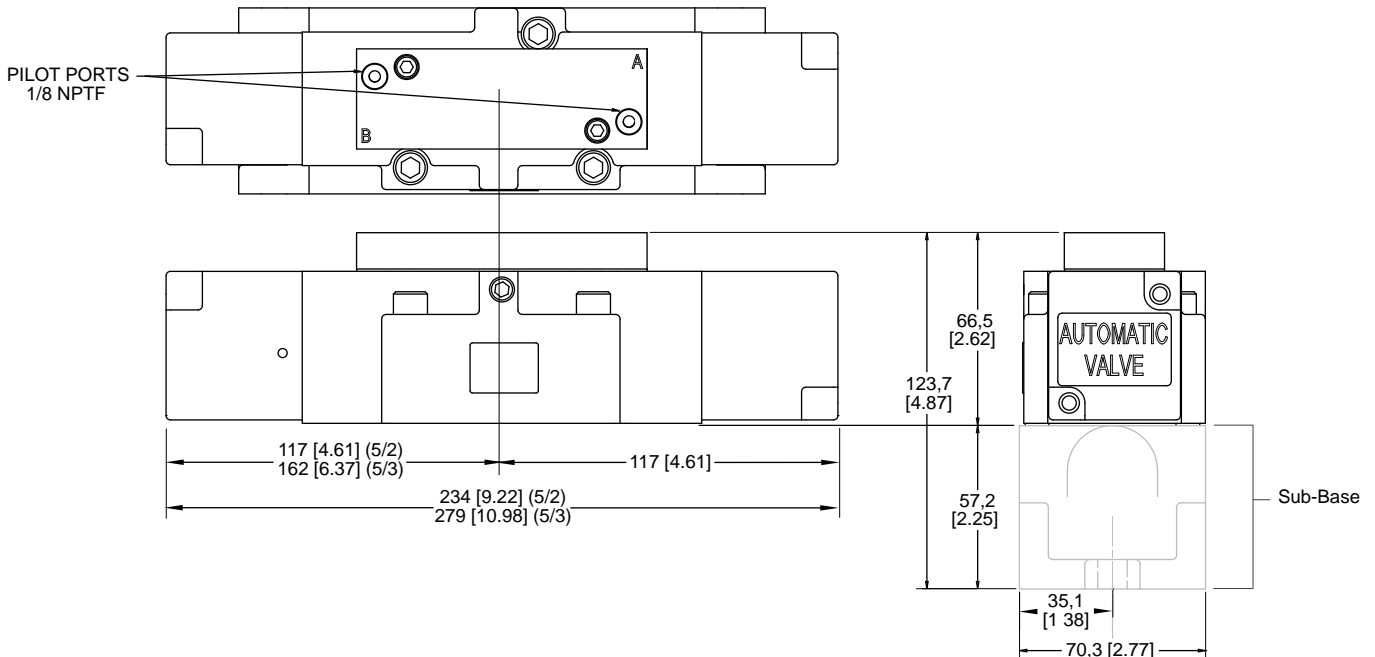

F

Units of Measure: Top - mm, Bottom - inches

5/2



5/3

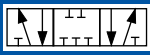

SAE Spool Valves Air Pilot

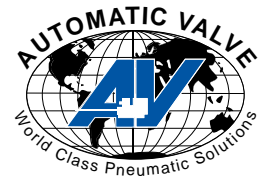

A20 (1000 Series) - Single

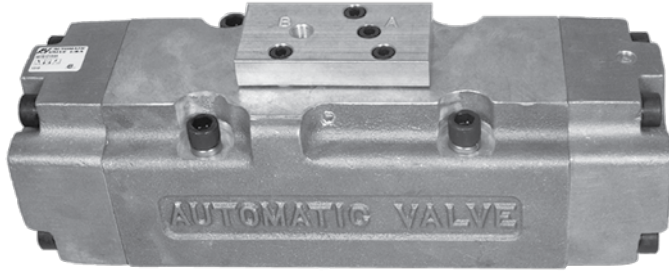

407B121A9A

A20 (1000 Series) - Double

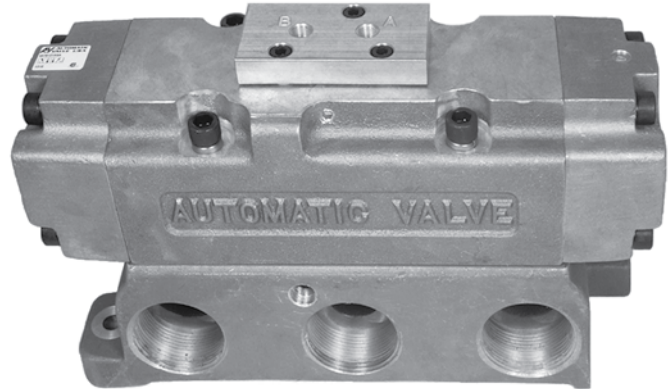

409B151A1A

F

Model Numbers

Body Type	Port Loc'n	Port Size	FLOW l/min (Cv)	5/2		5/3			Materials	Weight Kg (lb)
				Single	Double	Block	Exhaust	Pressure		
Valve Only		-	5/2 Flow: 22,340 (22.7) 5/3: 17425 (17.7)	407B121A9A	407B121A1A	407C121A9D1A	407D121A9D1A	407E121A9D1A	Seal+NBR Body=Aluminum	8,0 (17.8)
Valve + Sub-Base	Base	1		409B101A9A	409B101A1A	409C101A9D1A	409D101A9D1A	409E101A9D1A		11,3 (25.1)
		1 1/4		409B121A9A	409B121A1A	409C121A9D1A	409D121A9D1A	409E121A9D1A		
		1 1/2		409B151A9A	409B151A1A	409C151A9D1A	409D151A9D1A	409E151A9D1A		

Dimensional Information

A20 (1000 Series) - Single

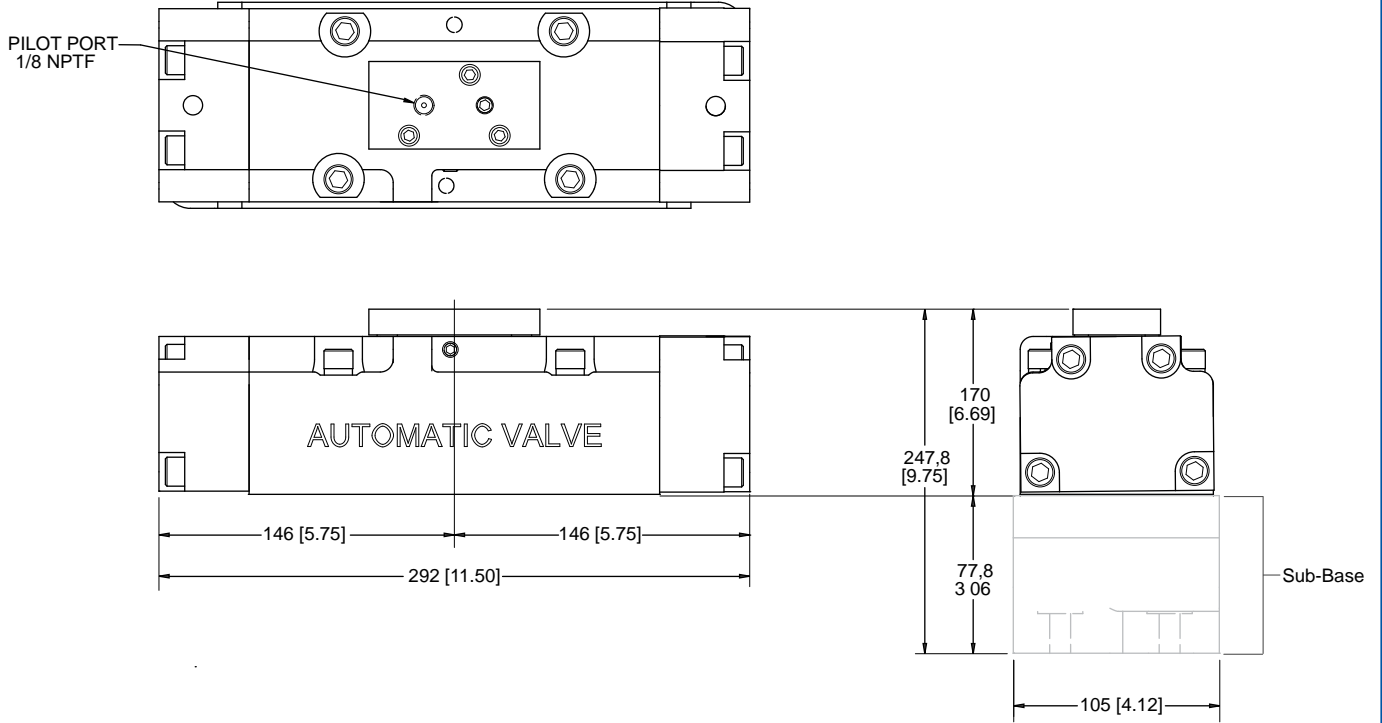

A20 (1000 Series) - Double

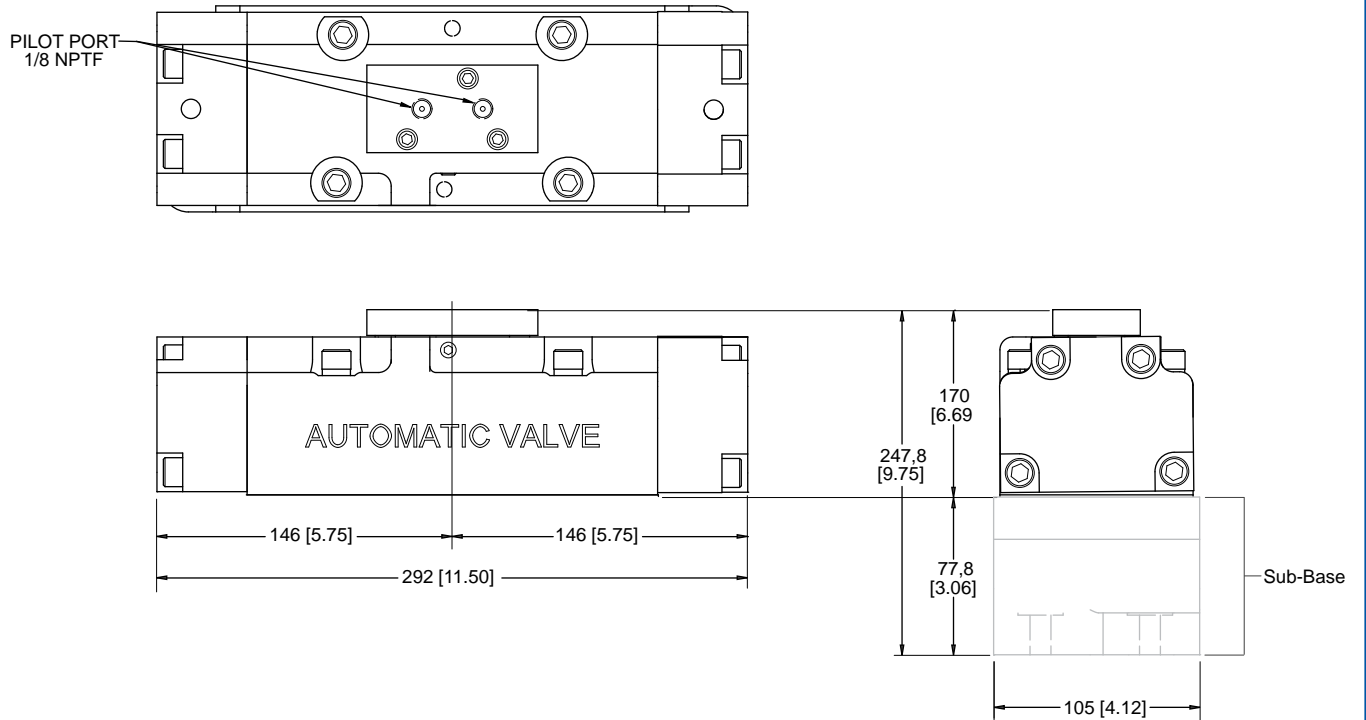

Units of Measure: Top - mm, Bottom - inches

5/2



SAE Spool Valves Manual

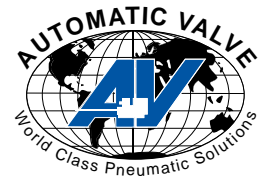

A04 (125 Series)

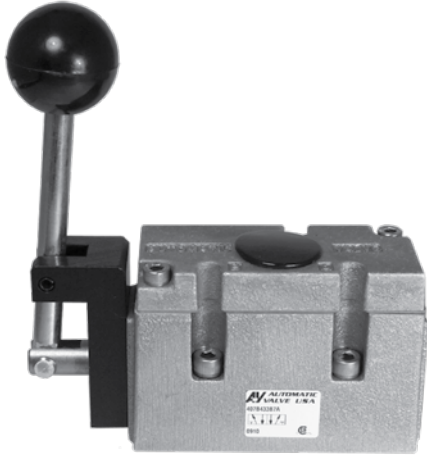

407B433B7A

A06 (250 Series)

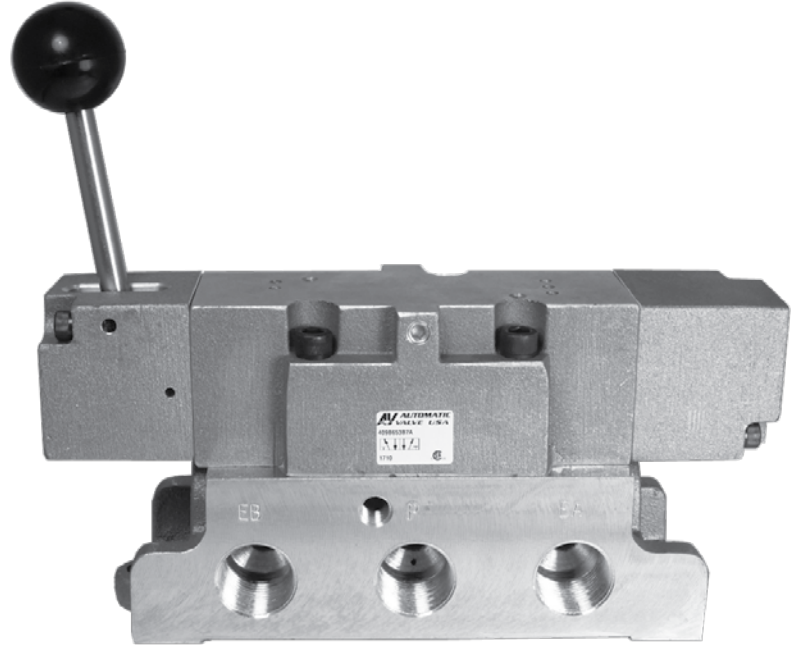

409B673B7A

Model Numbers

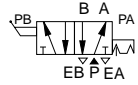
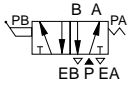
	Body Type	Port Loc'n	Port Size	Flow (5/2) l/min (Cv)	Operator	5/2		Material		Wt Kg (lb)
						Detented	Spring Return	Body	Seal	
										
F A04	Valve Only	Base	-	2360 (2.4)	Hand Lever Line Mounted	407B433B7A	407B433B9A	Aluminum	NBR	1,0 (2.3)
	Valve + Sub-Base		1/4			409B423B7A	409B423B9A			1,4 (3.2)
	Valve + Manifold (Bottom Cyl Ports)		3/8			413B433B7A	413B433B9A			1,5 (3.3)
	Valve + Manifold (Bottom/Side Cyl Ports)		3/8			416B433B7A	416B433B9A			1,7 (3.7)
A06	Valve Only	Base	-	8460 (8.6)	Hand Lever Line Mounted	407B673B7A	407B673B9A	Aluminum	NBR	3,1 (6.9)
	Valve + Sub-Base		1/2			409B653B7A	409B653B9A			4,3 (9.6)
			3/4			409B673B7A	409B673B9A			
			1			409B603B7A	409B603B9A			
	Valve + Manifold (Bottom Cyl Ports)		1/2			413B653B7A	413B653B9A			3,9 (8.7)
			3/4			413B673B7A	413B673B9A			

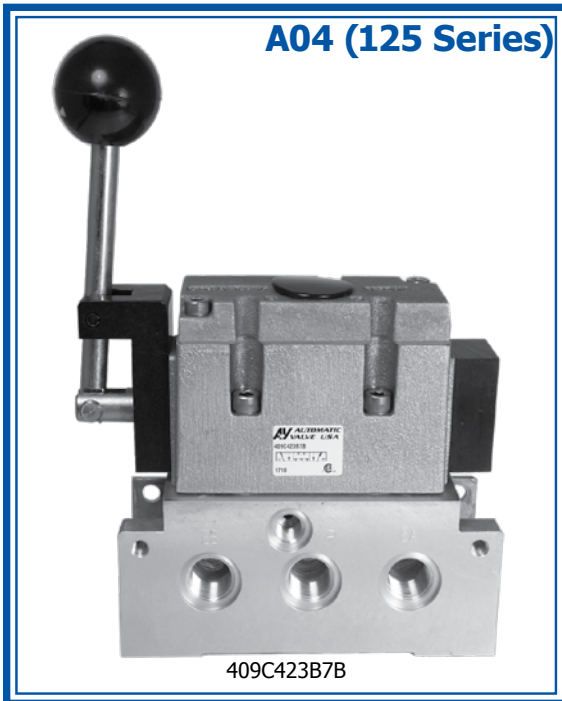
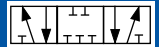

Model Numbers

Series	Body Type	Port Size	Flow 5/3 l/min (Cv)	Operator	5/3 (4 Way 3 Position)						Materials	Weight kg (lb)
					Detented			Spring Center				
					Block	Exhaust	Pressure	Block	Exhaust	Pressure		
A04	Valve only	-	2360 (2.4)	Hand Lever, Line Mounted	407C433B7B	407D433B7B	407E433B7B	407C433B9B	407D433B9B	407E433B9B	Body = Aluminum Seal = NBR	1,0 (2.3)
	Valve + Sub-Base	1/4			409C423B7B	409D423B7B	409E423B7B	409C423B9B	409D423B9B	409E423B9B		1,4 (3.2)
	Valve + Manifold (Bottom Cyl Ports)	3/8			413C433B7B	413D433B7B	413E433B7B	413C433B9B	413D433B9B	413E433B9B		1,5 (3.3)
	Valve + Manifold (Bottom/Side Cyl Ports)	3/8			416C433B7B	416D433B7B	416E433B7B	416C433B9B	416D433B9B	416E433B9B		1,7 (3.7)
A06	Valve Only	-	8460 (8.6)	Hand Lever, Line Mounted	407C673B7B	407D673B7B	407E673B7B	407C673B9B	407D673B9B	407E673B9B	Body = Aluminum Seal = NBR	3,1 (6.9)
	Valve + Sub-Base	1/2			409C653B7B	409D653B7B	409E653B7B	409C653B9B	409D653B9B	409E653B9B		4,3 (9.6)
		3/4			409C673B7B	409D673B7B	409E673B7B	409C673B9B	409D673B9B	409E673B9B		
		1			409C603B7B	409D603B7B	409E603B7B	409C603B9B	409D603B9B	409E603B9B		
	Valve + Manifold (Bottom Cyl Ports)	1/2			413C653B7B	413D653B7B	413E653B7B	413C653B9B	413D653B9B	413E653B9B		3,9 (8.7)
		3/4			413C673B7B	413D673B7B	413E673B7B	413C673B9B	413D673B9B	413E673B9B		

F

5/2



5/3

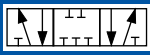

SAE Spool Valves Manual

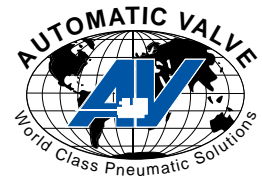

Dimensional Information

A04 (125 Series) Hand Lever

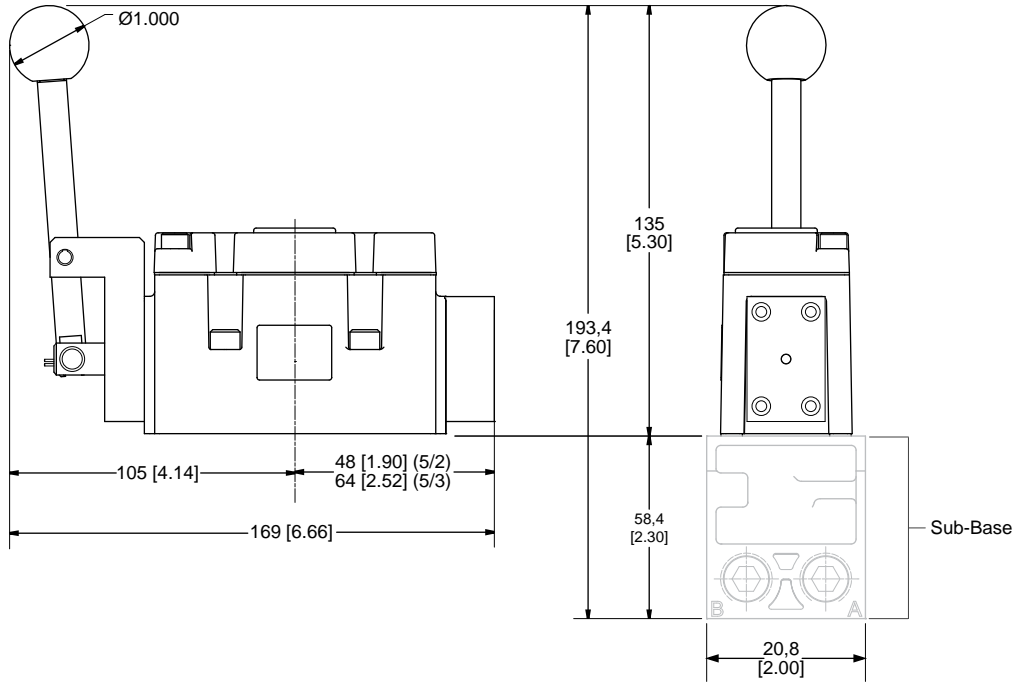

A06 (250 Series) Hand Lever

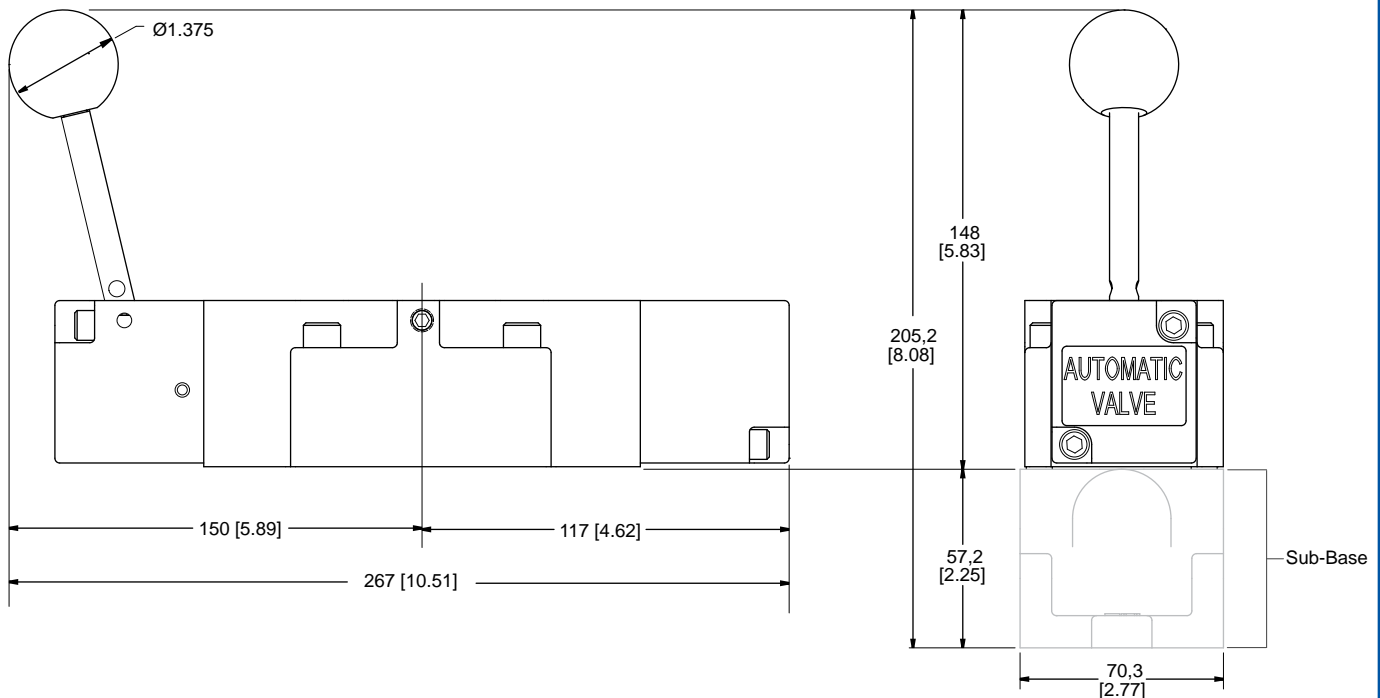

Units of Measure: Top - mm, Bottom - inches

Sub-Bases (409)

A04



A6318-025

A06

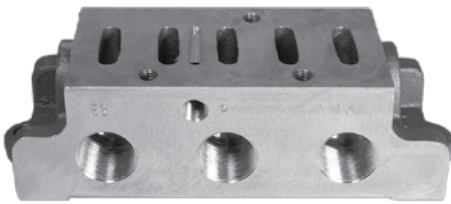

A6331-075

A20

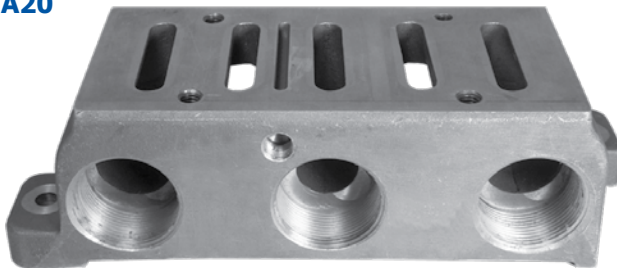

A5247-150

Manifolds (413 & 416)

A04



A6250-038 (413)
A6880-120 (416)

A06 (413)

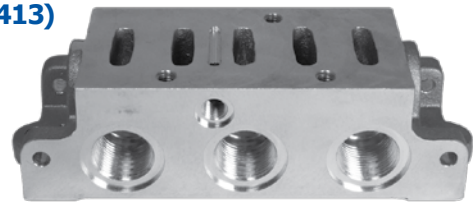

A6265-075

A06 (416)

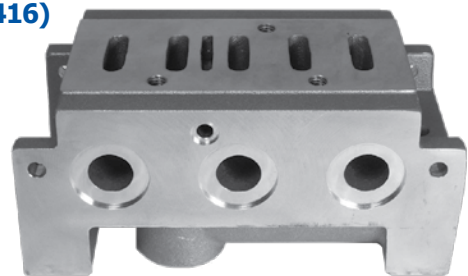

A6886-120

F

Model Numbers

SAE AV Series	Automotive Series	409		413				416						
		Individual Sub-Base		Manifold ¹ Bottom Cylinder Ports		Manifold Accessories		Manifold ¹ Bottom/Side Cylinder Ports			Manifold Accessories			
		409 Model Numbers	Cyl Port Size	413 Model Numbers	Port Size		Blocking Disk	Blank Station Covers ²	416 Model Numbers	Port Size		Blocking Disk	Blank Station Covers ²	End Plate Kit
			P EA EB	A B		P EA EB			A B					
A04	125	A6318-025	1/4	A6250-038	3/8	3/8	0957-038	A6658	A6880-120	3/8	3/8	A7002-010	A6658	-
A06	250	A6331-050	1/2	A6265-050	3/4	1/2	0957-075	A5903	A6886-120	3/4	1/2	A7002-020	A5903	B6891
		A6331-075	3/4						A6886-130	3/4	3/4			
		A6331-100	1											
A20	1000	A5247-125	1 1/4	-	-	-	-	-	-	-	-	-	-	
		A5247-150	1 1/2											

¹ Seals and mounting hardware are included

² Each Blank Station requires a cover.

5/2



5/3

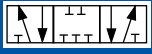

SAE Spool Valves Sub-Bases & Manifolds

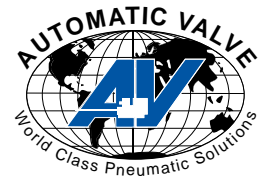

Dimensional Information

A04 Sub-Base (409)

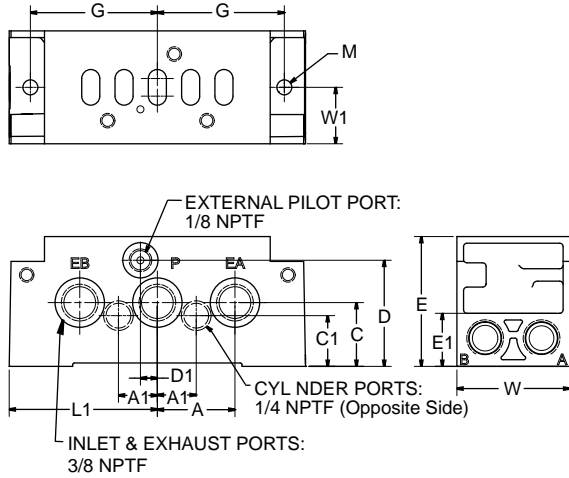

A06 Sub-Base (409)

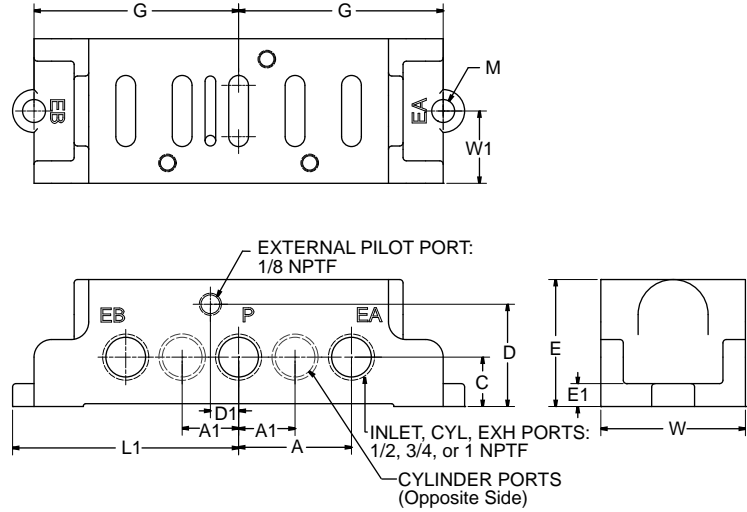

A20 Sub-Base (409)

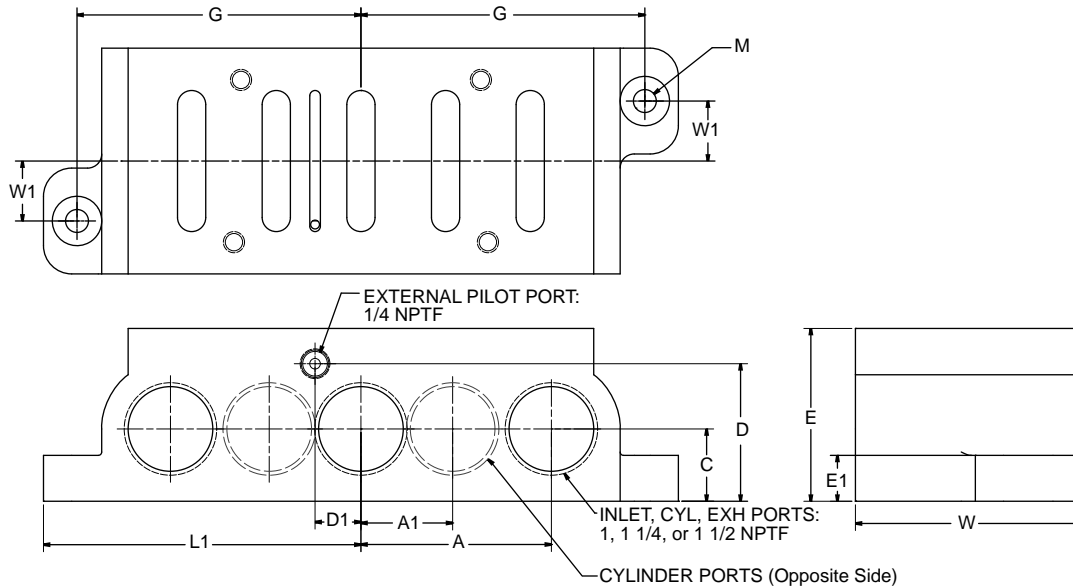

Series	Model	A	A1	C	C1	D	D1	E	E1	G	L1	M	W	W1
A04 (125)	409	35,1 1.38	175 0.69	28,7 1.13	22,9 0.90	47,8 1.88	7,62 0.30	58,4 2.30	23,9 0.94	57,2 2.25	66,68 2.63	6,6 0.26	50,8 2.00	25,4 1.00
A06 (250)	409	50,8 2.00	25,4 1.00	22,2 0.88	-	46,0 1.81	12,7 0.50	57,2 2.25	10,3 0.41	92,1 3.63	91,95 3.63	10,2 0.41	70,3 2.77	35,1 1.38
A20 (1000)	409	85,7 3.38	41,3 1.63	3,25 1.28	-	61,9 2.44	20,6 0.81	77,8 3.06	20,6 0.81	128 5.03	143 5.62	10,3 0.41	105 4.12	26,9 1.06

Units of Measure: Top - mm, Bottom - inches

Dimensional Information

A04 Manifold (Bottom Cylinder Ports) (413)

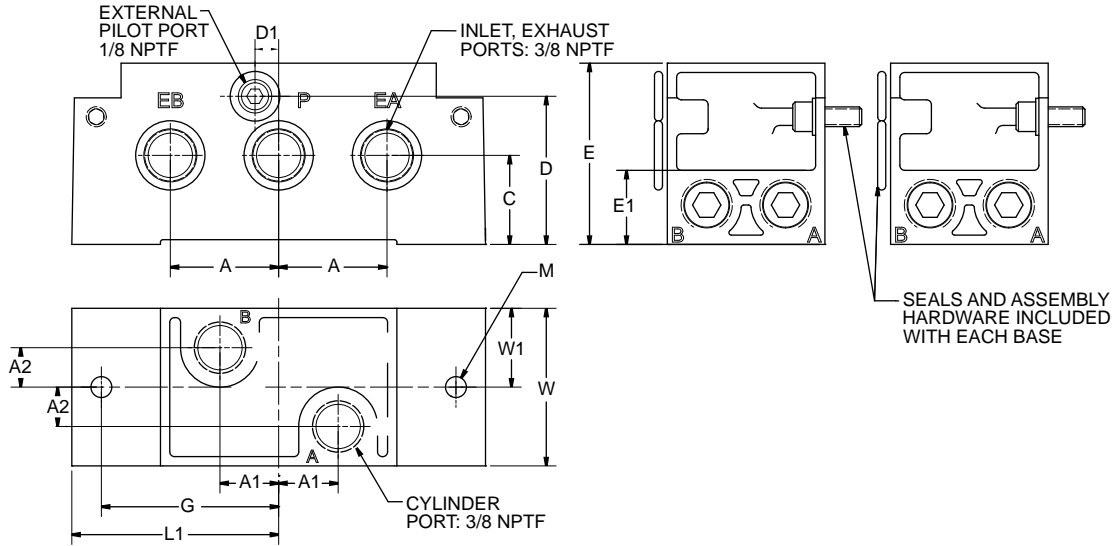

A06 Manifold (Bottom Cylinder Ports) (413)

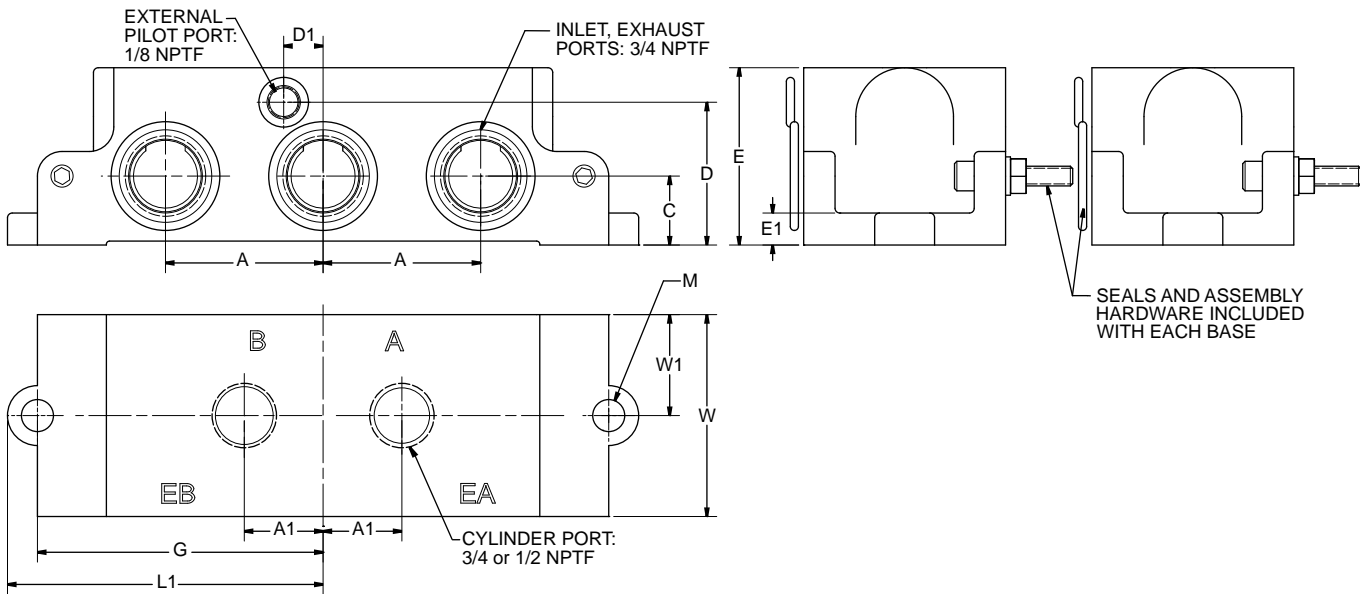

F

Series	Model	A	A1	A2	C	D	D1	E	E1	G	L1	M	W	W1
A04 (125)	413	35,1 1.38	19,1 0.75	12,7 0.50	28,7 1.13	47,8 1.88	7,62 0.30	58,4 2.30	23,9 0.94	57,2 2.25	66,5 2.62	6,6 0.26	50,8 2.00	25,4 1.00
A06 (250)	413	50,8 2.00	25,4 1.00	22,2 1.88	50,8 2.00	71,5 2.81	12,7 0.50	82,6 3.25	10,3 0.41	79,4 3.12	88,9 3.50	8,7 0.34	88,9 3.50	44,5 1.75

Units of Measure: Top - mm, Bottom - inches

5/2



5/3

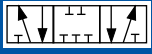

SAE Spool Valves Sub-Bases & Manifolds

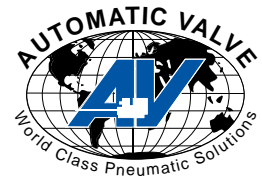

Dimensional Information

A04 Manifold (Bottom/Side Cylinder Ports) (416)

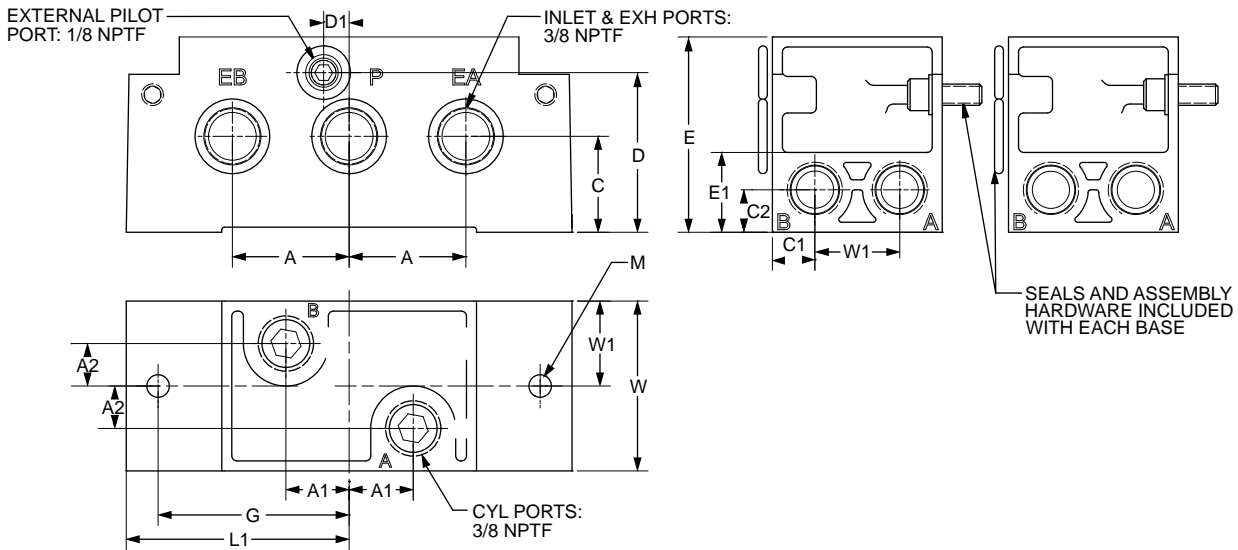

A06 Manifold (Bottom/Side Cylinder Ports) (416)

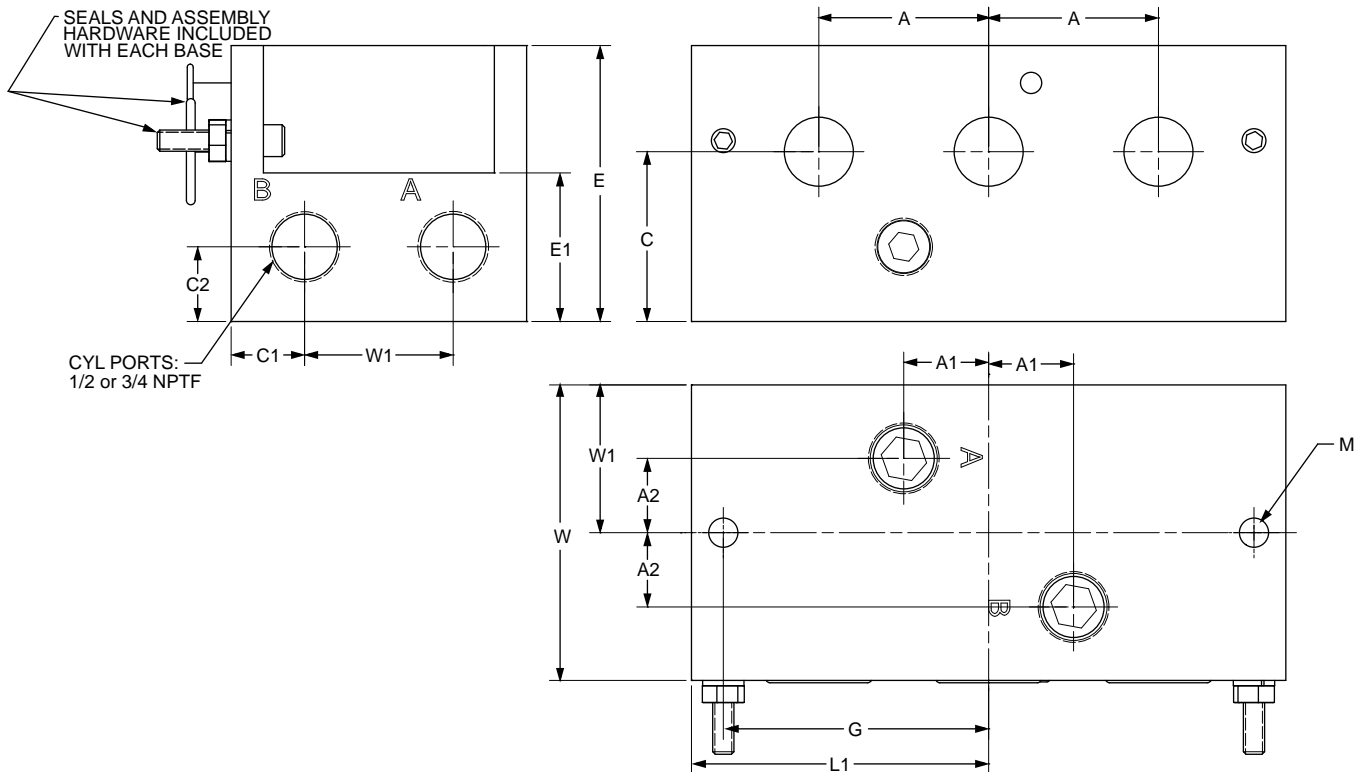

Series	Model	A	A1	A2	C	C1	C2	D	D1	E	E1	G	L1	M	W	W1
A04 (125)	416	34,9 1.38	18,9 0.75	12,7 0.50	28,7 1.13	12,7 0.50	12,7 0.50	47,8 1.88	7,62 1.30	58,4 2.30	23,9 1.94	57,2 2.25	66,7 2.62	6,73 0.26	50,8 2.00	25,4 1.00
A06 (250)	416	50,8 2.00	25,4 1.00	22,2 0.88	50,8 2.00	22,2 0.88	22,2 0.88	46,0 1.81	12,7 0.50	82,6 3.25	44,5 1.75	79,4 3.12	88,9 3.50	8,73 0.34	88,4 3.48	44,2 1.74

Units of Measure: Top - mm, Bottom - inches

Options (Add the suffix to the end of the Model Number in alpha-numeric order)

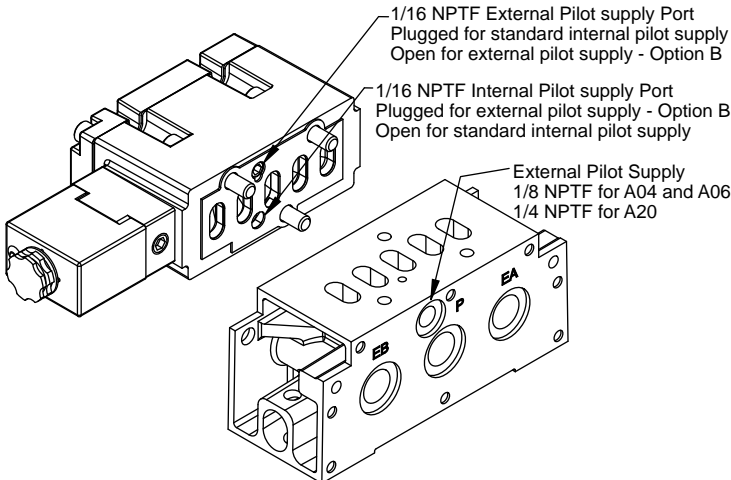
Suffix	Option	Description
A	Fluoroelastomer Seals	For applications where fluid media or ambient conditions are not compatible with nitrile seals. <i>Note: Fluorocarbon seals do not increase the effective temperature range of the valve. For high temperature applications, consult the factory.</i> (Available for A04 and A06 Only)
B	External Pilot	For solenoid applications where the pressure to port one is less than 2 BAR (35 PSIG). See example below for field conversion.
		<p style="text-align: center;">Field Conversion</p>  <ul style="list-style-type: none"> Remove the valve from the sub-base and turn upside down. Remove the 1/16 NPTF pipe plug from the external pilot supply port in the valve and install it in the supply port. Connect the air supply to the external pilot supply port in the base.
D	Dustproof	For applications in extremely dusty and contaminated environments. Vent ports are plugged and spring pad breather vent is eliminated.
Y	Explosion-Proof Coil (CSA, FM)	Refer to the "Electrical Information" page in this section for details.
0	GM - 5 Pin Micro	Customer Specification for Connector Wiring. For more information see the Wiring Chart on the Service Information page in this section.
1	Ford - 5 Pin Micro	
2	Chrysler - 5 Pin Micro AC/DC	
3	GM - 5 Pin Mini	
4	Ford - 5 Pin Mini	
5	Chrysler - 5 Pin Mini	
6	GM - 4 Pin Micro DC	
7	Ford - 4 Pin Micro DC	

Accessories

Interposed Flow Control

- Restricts air flow from Port A to Port EA and from Port B to Port EB.
- Mounts between the valve and the sub-base or between the valve and the single pressure regulator.
- Vibration-proof metering control
- Interposed Flow Controls cannot be used with Interposed Dual Pressure Regulators.

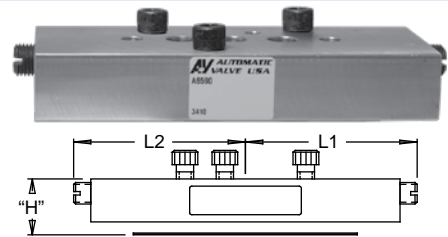
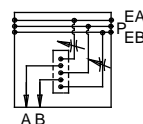

AV Series (SAE)	Model Number	Weight		Dimensions		
		Kg (lb)	H	L1	L2	
A04 (125)	A6590	0,3 (0.7)	19,8 (0.78)	63,5 (2.50)	63,5 (2.50)	

5/2



5/3

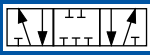

SAE Spool Valves Accessories

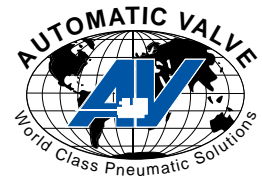

Sandwich Single Pressure Regulator

Features

- Regulates single inlet pressure from Inlet Port P to Cylinder Ports A & B.
- Mounts between the valve and sub-base.
- Two Pressure Ranges: 0,6-4,1 BAR (5- 60 PSIG); and 0,7-9,0 BAR (10- 130 PSIG).
- 1/8 NPTF gage port.
- On series A04, color coded locking rings identify the pressure range: Yellow 5- 60PSIG; Red 10- 130PSIG.
- In series A06 the fingertip control knob and locking nut are standard.
- If pressure is less then 2 BAR (35 PSIG) , then valve must be externally piloted [3,4 BAR (50 PSIG) for 3 position valves].

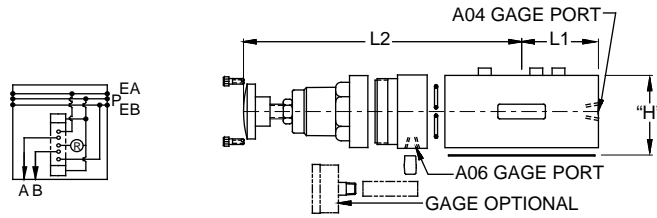

AV Series (SAE)	Type	Model Number		Weight Kg (lb)	Dimensions (top-mm; bottom-inches)		
		5- 60 PSIG	10- 130 PSIG		H	L1	L2
A04 (125)	Regulator	B6691-060	B6691-130	0,5 (1.2)	37,3 1.47	54,9 2.16	107 4.25
	Gage	A5655-060	A5655-160	-	-	-	-
A06 (250)	Regulator	B6693-060	B6693-130	1,5 (3.5)	63,5 2.5	66,7 2.63	208 8.23
	Gage	A6785-060	A6785-160	-	-	-	-

Sandwich Dual Pressure Regulator



Features

- Regulates dual inlet pressure from EA - EB to cylinder ports A & B.
- Mounts between the valve and sub-base.
- Two Pressure Ranges: 0,3-4,1 BAR (5- 60 PSIG); and 0,7-9,0 BAR (10- 130 PSIG).
- 1/8 NPTF gage port.
- On series A04, color coded locking rings identify the pressure range: Yellow 5- 60; Red 10- 130 PSIG.
- In series A06 the fingertip control knob and locking nut are standard.
- Dual Pressure Regulators require a valve external pilot supply and cannot be used with sandwich flow controls.

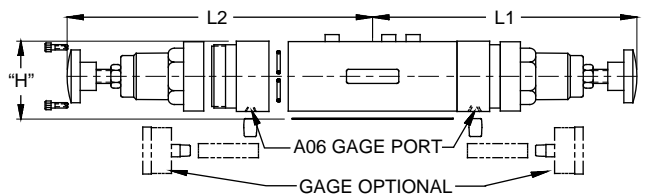
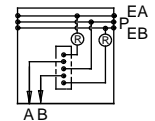

AV Series (SAE)	Type	Model Number		Weight Kg (lb)	Dimensions (top-mm; bottom-inches)		
		5- 60 PSIG	10- 130 PSIG		H	L1	L2
A04 (125)	Regulator	-	B6692-130-130	0,6 (1.3)	37,3 1.47	108 4.25	108 4.25
	Gage	-	-	-	-	-	-
A06 (250)	Regulator	-	B6694-130-130	2,6 (5.6)	63,5 2.50	208 8.23	208 8.23
	Gage	A6785-060	A6785-130	-	-	-	-

Part Numbers

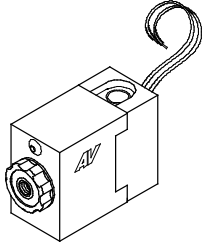
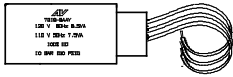
Description	Operator Type	Instructions	Kg (lb)	Coil Part Number **=Voltage
Weather-Proof 18" Leads NEMA 4X 	S	Coil included (specify voltage code from table below)	0,12 (0.27)	A7201-**
Explosion-Proof 1/2" Conduit with 24" Leads CSA & FM Approved CL. I; Zone1 ExmIIT4; AExmII CL. I; Div.1; GR. A, B, C, D CL. II; GR. E, F, G CL. III T4 Ta=-20°C to +60°C NEMA 4, 4X, 7C, 7D, 9 	Y	Coil included (specify voltage code from table below)	0,20 (0.44)	7019-9**Y

Voltage Codes

** Code	Voltage +/-10%		Current (Amps)				Resistance (OHMS @ 25°C)		Power (AC=VA, DC=Watts)	
			Inrush		Holding		S	Y	S	Y
	Operator Type:		S	Y	S	Y	S	Y	S	Y
	NEMA		NEMA							
4	7, 9	4	7, 9	4	7, 9	4	7, 9	4	7, 9	
AA	120/50 120/60	120/60	.07	.10	.05	.05	908	530	6.9	6.5
AB	240/50 240/60	240/60	.15	.05	.13	.03	3630	2345	6.9	6.8
DA	12 VDC	12 VDC	.37	.38	.37	.38	33	32	4.4	4.5
DB	24 VDC	24 VDC	.18	.19	.18	.19	130	128	4.4	4.5
AB	125 VDC	-	.03	-	.03	-	3630	-	4.8	-
DE	-	125 VDC	-	.04	-	.04	-	2820	-	5.5

F

Connectors

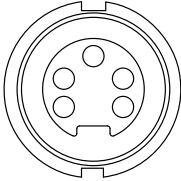
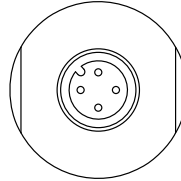
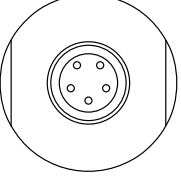
			
Type	5 pin mini	4 pin micro	5 pin micro
Connection	1/2-14-NPT	M12x1	M12x1
Options	3, 4, 5	6, 7	0, 1, 2
Part Number	6095	6095-002	6095-003

5/2



5/3

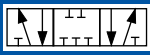

SAE Spool Valves Service Information

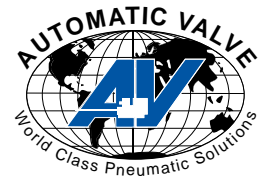

Wiring

Options					Pin Number									
4 pin Micro	5 Pin Micro	5 Pin Mini	Cst.	Schematic [For SGL Solenoid use Sol B pin out] (See next Page for Wiring & Service Diagram)	1		2		3		4		5	
					Lead	Connects To	Lead	Connects To	Lead	Connects To	Lead	Connects To	Lead	Connects To
-	0	-	GM		Red/White	Sol A Brown	Red	Sol B Black	Green	Ground	Red/Yellow	Sol B Brown	Red/Black	Sol A Black
-	1	-	Ford		Red/White	Sol B Brown	Red	Sol A Black	Green	Ground	Red/Yellow	Sol A Brown	Red/Black	Sol B Black
-	2 AC	-	Chrysler		Red/White	Sol A Brown	Red	Sol A Black	Green	Ground	Red/Yellow	Sol B Brown	Red/Black	Sol B Black
-	2 DC	-	Chrysler		Red/White	Sol A Brown	Red	Sol B Brown	Green	Ground	Red/Yellow	Sol A Black	Red/Black	Sol B Black
-	-	3	GM		Red/White	Sol A Brown	Red	Sol B Black	Green	Ground	Red/Yellow	Sol B Brown	Red/Black	Sol A Black
-	-	4	Ford		Red/White	Sol B Brown	Red	Sol A Brown	Green	Ground	Red/Yellow	Sol A Black	Red/Black	Sol B Black
-	-	5	Chrysler		Red/White	Sol A Brown	Red	Sol A Black	Green	Ground	Red/Yellow	Sol B Brown	Red/Black	Sol B Black
6	-	-	GM		Brown	Sol A Brown	White	-	Blue	Sol A Sol B (Black)	Black	Sol B Brown	None	
7	-	-	Ford		Brown	-	White	Sol A Brown	Blue	Sol A Sol B (Black)	Black	Sol B Brown	None	

F

Wiring & Service Diagram

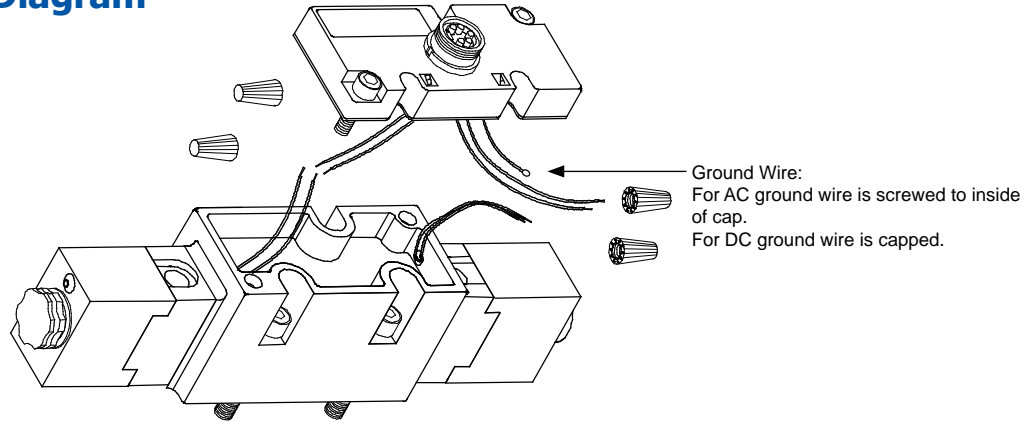

Assembly: Valve to Manifold Base

413 Assembly

Instructions:

- STEP 1: Place O-Rings in counterbores in base.
- STEP 2: Assemble base to base using screws, washers, and nuts.

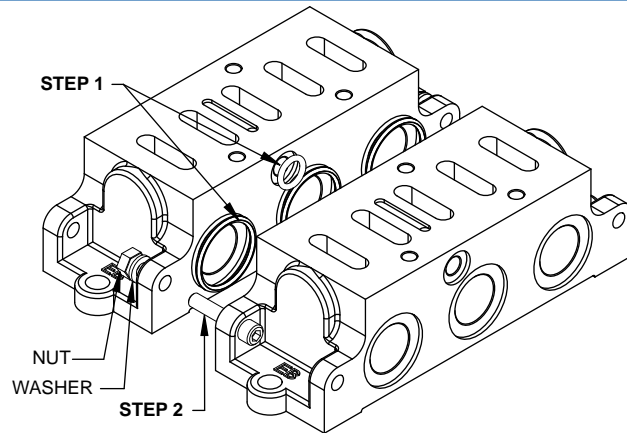

416 Assembly

Instructions:

- STEP 1: Place O-Rings in counterbores of end caps.
- STEP 2: Assemble cap to base using screws, washers, and nuts.
- STEP 3: Place O-Rings in counterbores of base.
- STEP 4: Assemble base to base using screws, washers, and nuts.

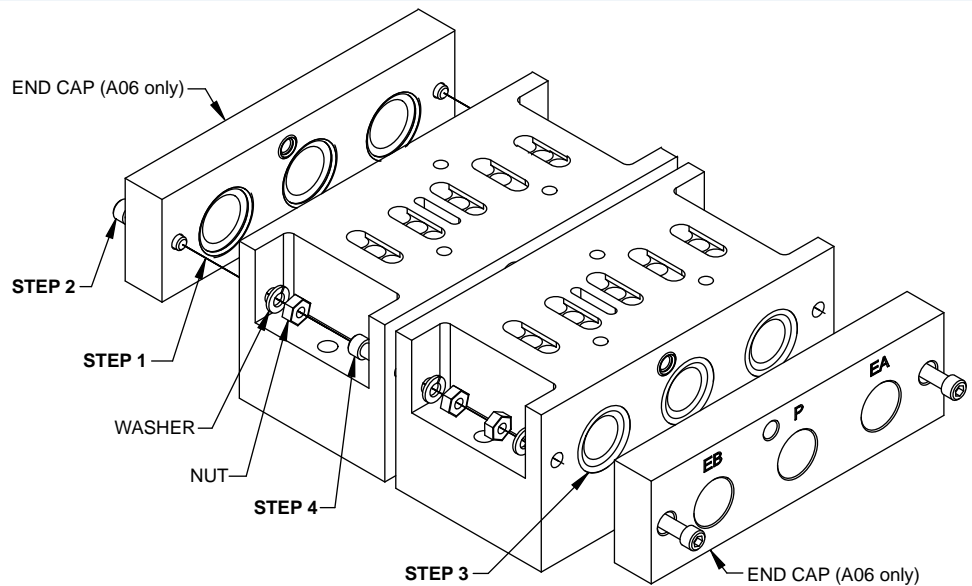

F

5/2



5/3

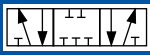

SAE Spool Valves Service Information

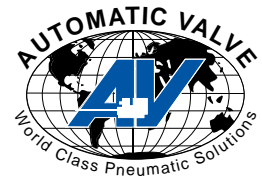

A04 (125 Series)

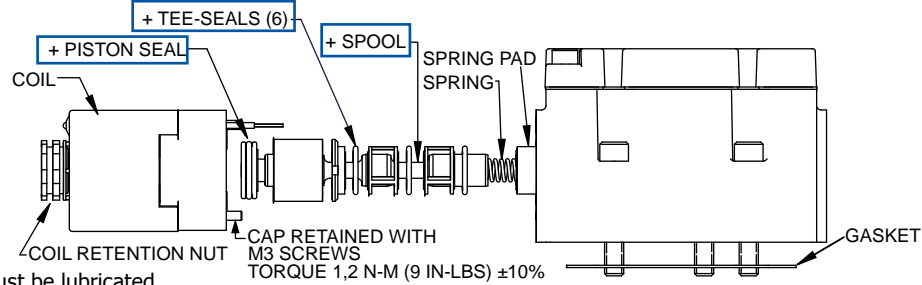

+ = items that must be lubricated

Service Kit Installation Instructions

- Follow appropriate lock-out/tag-out procedures. Do not attempt to service a valve, if you are not familiar with lock-out/tag-out procedures.
- Turn off electrical power to the valve.
- Remove valve from all electrical and air power sources.
- Ensure all stored air power is exhausted.
- Remove coil by first removing coil pretention nut.
- Remove operator cap by first removing 4 socket head cap screws.
- Remove existing serviceable components by "pushing" internal components gently out of the valve body.
- Clean the spool with a clean cloth.
- Discard the spring (Single Spring Return models only).
- Lubricate the designated "+" items in above assembly drawing with a thin film of lubricant - the item should look "WET" with no excess lubricant visible.
- Replace components as shown above.
 - Replace spring pad (where required) & spring (Single Spring Return Models Only).
 - Alternate Tee-seals and spacers.
 - Once all 6 Tee-seals are installed, replace the retainer, bushing & piston, and spool.
- Orientate the operator cap by aligning the open end of the gasket with the pilot hole in the valve body. (For external pilot, this hole is covered; see Field Conversion on Options Page.)
- Torque cap screws into body to 1,02 N-m (9 in-lbs) $\pm 10\%$. Alternate tightening of the screws, so cap "squeezes" evenly onto body.

Valve must be disconnected from all air and electrical power sources before disassembly.

A06 (250 Series)

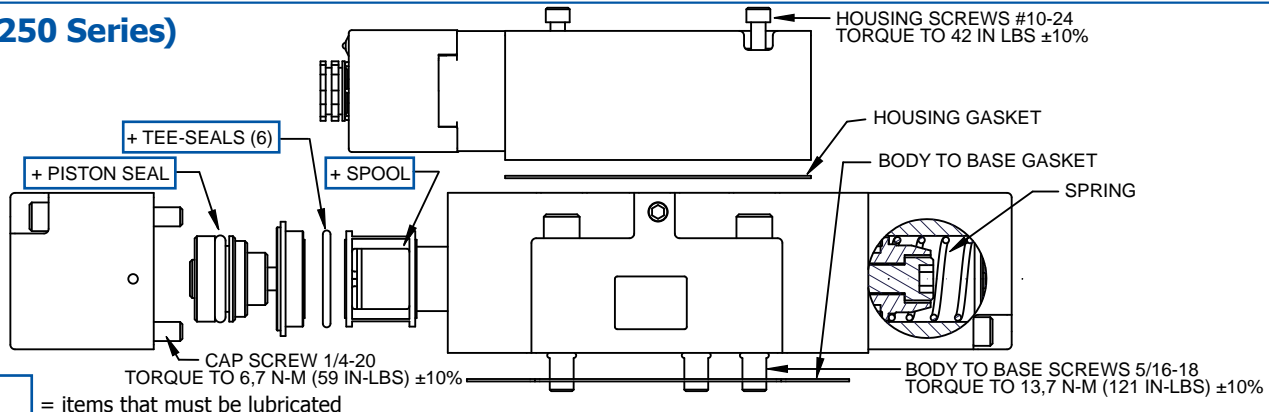

+ = items that must be lubricated

Service Kit Installation Instructions

- Follow appropriate lock-out/tag-out procedures. Do not attempt to service a valve, if you are not familiar with lock-out/tag-out procedures.
- Turn off electrical power to the valve.
- Remove valve from all electrical and air power sources.
- Ensure all stored air power is exhausted.
- Remove end caps by first removing 2 socket head cap screws.
- Remove existing serviceable components by "pushing" internal components gently out of the valve body.
- Clean the spool with a clean cloth.
- Discard the spring (Single Spring Return Models Only).
- Lubricate the designated "+" items in the above assembly drawing with a thin film of lubricant - the item should look "WET" with no excess lubricant visible.
- Replace components as shown above.
 - Alternate Tee-seals and spacers.
 - Once all 6 Tee-seals are installed, insert the retainer and piston into end cap. Insert O-ring in end cap.
 - Replace spring (Single Spring Return models only).
- Orientate spool as shown above.
- Make sure rubber plug is still present in body. (9A Oper. Only)
- Orientate the caps by aligning the pilot hole in the valve body with the pilot hole in the cap. (For external pilot, this hole is covered; see Field Conversion on Options Page in this Section.)
- Torque cap screws into body to 6,7 N-m (59 in-lbs) $\pm 10\%$. Alternate tightening of the screws, so that cap "squeezes" evenly onto body.
- Replace the housing gasket, if necessary. Torque housing screws to 4,8 N-m (42 in-lbs) $\pm 10\%$. Take care not to scratch interface surface.
- Replace the body-to-base gasket, if necessary. Torque body-base screws to 13,7 N-m (121 in-lbs) $\pm 10\%$.

Valve must be disconnected from all air and electrical power sources before disassembly.

A20 (1000 Series)

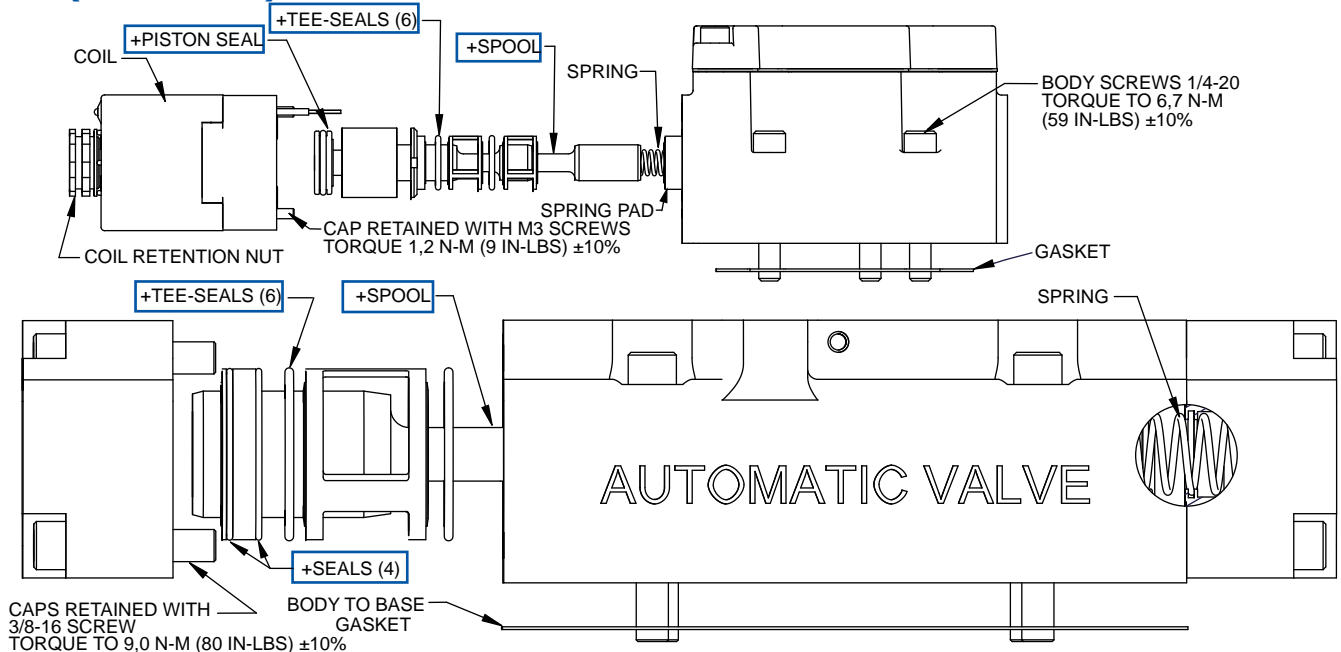

+ = items that must be lubricated

Service Kit Installation Instructions

1. Follow appropriate lock-out/tag-out procedures. Do not attempt to service a valve, if you are not familiar with lock-out/tag-out procedures.
2. Turn off electrical power to the valve.
3. Remove valve from all electrical and air power sources.
4. Ensure all stored air power is exhausted.
5. Remove plate (for air pilot) or operating valve (A04 for solenoid valves).
6. For solenoid valves follow the Service Kit Installation Instructions for the A04 (see previous page).
7. To service the A20 valve body follow the Service Kit Installation Instructions for the A06 (see previous page), except on Step 14, torque cap screws to 9,0 N-m (80 in-lbs) ±10%.
8. Replace the gasket between the A20 and the plate or A04 operating valve, if necessary. Do not scratch the interface surfaces.
9. Orientate the plate or A04 operating valve to the A20 body by aligning air pilot holes.
10. Torque cap screws into body to 6,7 N-m (59 in-lbs) ±10%. Alternate tightening of so that cap "squeezes" evenly onto body.

F

Air Line Lubrication of Automatic Valve products is not required, but is recommended to maximize service life. Oils should be compatible with seal material, have an ISO 32 or lighter viscosity, and have an aniline point between 82°C (180°F) and 99°C (210°F). Refer to the Maintenance Section of this catalog for recommended lubricants.

Model Numbers: Service Kits

Series	Function			
	Single		Double	
	Model Number	Contents	Model Number	Contents
A04	K-A04-SGL K-A04-SGL-A (fluoroelastamer)	Tee-Seals (6), Gasket (1), Piston Seal (1), Spring (1)	K-A04-DBL K-A04-DBL-A (fluoroelastamer)	Tee-Seals (6), Gasket (1), Piston Seals (2)
A06	K-A06-SGL K-A06-SGL-A (fluoroelastamer)	Tee-Seals (6), Gaskets (2), Piston Seal (1), Spring (1)	K-A06-DBL K-A06-DBL-A (fluoroelastamer)	Tee-Seals (6), Gaskets (2), Piston Seals (2)
A20	K-A20-SGL	Tee-Seals (12), Gaskets(2), Piston Seals(3), Springs(2)	K-A20-DBL	Tee-Seals (12), Gasket(2), Piston Seals (6)

5/2



5/3

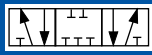

SAE Spool Valves Notes

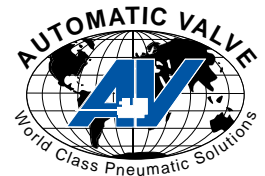

A large rectangular area with a light blue grid pattern, intended for handwritten notes.

F

AV AUTOMATIC VALVE

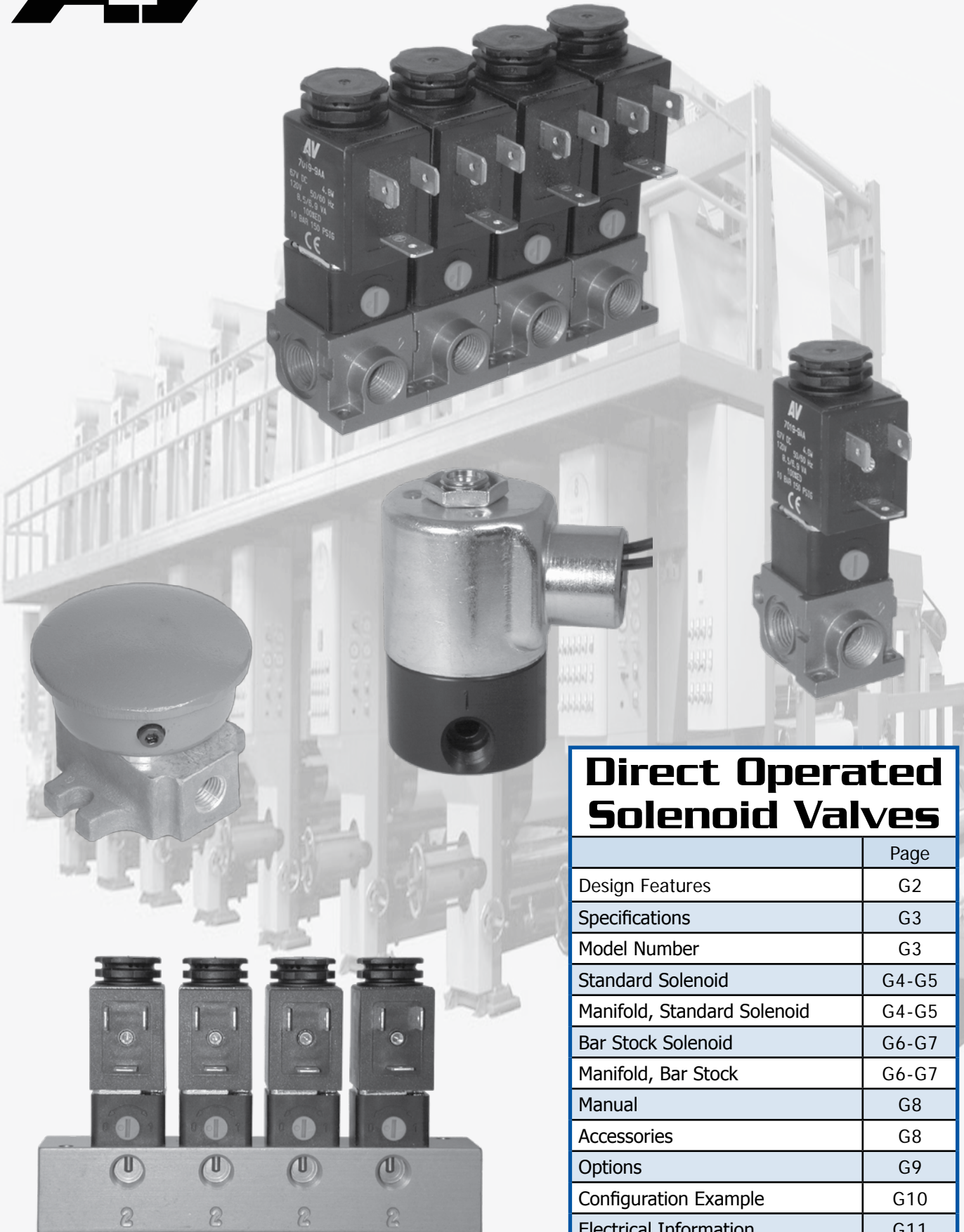

Direct Operated Solenoid Valves	
	Page
Design Features	G2
Specifications	G3
Model Number	G3
Standard Solenoid	G4-G5
Manifold, Standard Solenoid	G4-G5
Bar Stock Solenoid	G6-G7
Manifold, Bar Stock	G6-G7
Manual	G8
Accessories	G8
Options	G9
Configuration Example	G10
Electrical Information	G11

2/2 

3/2 

Direct Operated Solenoid Valves Design Features

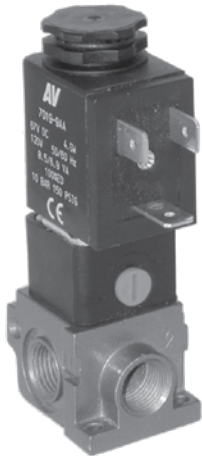
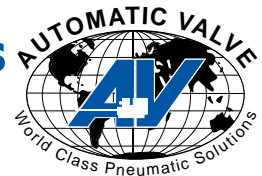

K0222JAXR-AA



K0302JABR

Direct Solenoid Valves

- Direct acting solenoid valves for compact, low profile and high performance.
- 2 way or 3 way function.
- Push Turn-Locking Override is standard
- Many options are available to meet your specific requirements: materials, flows, environmental ratings, manifolding. Please consult the factory.
- Specific application needs? Consult the factory. We will build it for you.



K08: 260A-2G

Manual Valves

- Long life poppet construction.
- Corrosion resistant internals.
- Body design simplifies mounting and piping.
- Optional ring guard available to protect against accidental valve actuation.



Products Certified To:

- CSA - (C22.2 and UL STD 429)
- Factory Mutual - Explosion Proof Environments
- ATEX - Explosion Proof Environments
- CE - EMF and Low Voltage Directives



Direct Operated Solenoid Valve Specs & Model Numbers

2/2

3/2

Direct Operated Solenoid Valves

Specifications

Valve Operation		Valve Operation		
 DE-ENERGIZED ENERGIZED	2/2 Normally Closed De-Energized: Blocks Pressure Energized: Applies Pressure	 DE-ENERGIZED ENERGIZED	3/2 Normally Closed De-Energized: Exhausts Pressure Energized: Applies Pressure	
 DE-ENERGIZED ENERGIZED	2/2 Normally Open De-Energized: Applies Pressure Energized: Blocks Pressure	 DE-ENERGIZED ENERGIZED	3/2 Normally Open De-Energized: Applies Pressure Energized: Exhausts Pressure	
Operating Temperatures	Solenoid Pilot Operated	Buna-N Seals (NBR) (Standard-K08)	Fluoroelastomer Seals (FPM (FKM)) (Standard-K02; Option A-K03&K08)	
	Standard	-18°C to +50°C (0°F to +123°F)	-18°C to +50°C (0°F to +123°F)	
	High Temp Coil (Options CT and T)	-18°C to +82°C (0°F to +180°F)	-18°C to +82°C (0°F to +180°F)	
Operating Pressures	Solenoid Pilot Operated	Inlet Port	External Pilot Port	
	Standard	K02	Not Required	
		AC		100 - 1030 kPa (Vacuum - 150 PSIG)
		DC		100 - 517 kPa (Vacuum - 75 PSIG)
K03	AC	100 - 690 kPa (Vacuum - 100 PSIG)		
	DC	100 - 1030 kPa (Vacuum - 150 PSIG)		
	-	K08		
Filtration & Lubrication	Media - Air Or Inert Gas			
	Air Line Lubrication of Automatic Valve products is not required, but is recommended to maximize service life. Oils should be compatible with seal material, have an ISO 32 viscosity, and have an aniline range between 82°C (180°F) and 99°C (210°F). Filter to 50 microns or better. For temperatures below 40°F, air must be dry to prevent formation of ice. Refer to the Maintenance section of this catalog for recommended lubricants.			

Model Numbers

Series	Base Type	Port Size	Body Type	Body Design	Operator 1	Operator 2	Voltage ¹	Options*
K02	0 Valve Less Base	0 -	G H J K	A	X Weather-Proof Solenoid	R Spring Return	-AA 110/50, 120/60	C Conduit Coil
	2 Inline or Manifold	2 1/8					-AB 220/50, 240/60, 125VDC	CT Conduit Coil High Temperature
	2 Sub-Base	3 1/4					-DA 22/50, 24/60, 12VDC	G 18" Flying Leads
						-DB 24VDC	O Exhaust Nut	
K03	0 Inline	2 1/8		B D	Weather-Proof Solenoid Explosion-Proof Solenoid		S 303 Stainless Steel Body (Bar Stock only)	
		3 1/4					SS 316 Stainless Steel Body (Bar Stock only)	
							Y Explosion-Proof Coil	
							Z Explosion-Proof Coil	
							2 Extended Turn-Locking Override	
							4 No Override	
							A Fluoroelastomer Seals	
							F Potted Solenoid	
							T High Temperature Coil	

K08 Series	Body Type	Port Size	Function	Options*
260A	Inline	2 1/4	2 Way NC	A Fluoroelastomer Seals B Blue G Green R Red
360A			3 Way NO	

* Not all Options are available for all models. Refer to "Options" at the end of this Section for additional information.

¹ Consult the Factory for additional voltages.

2/2 

3/2 

Direct Operated Solenoid Valve Standard Solenoid & Manifold

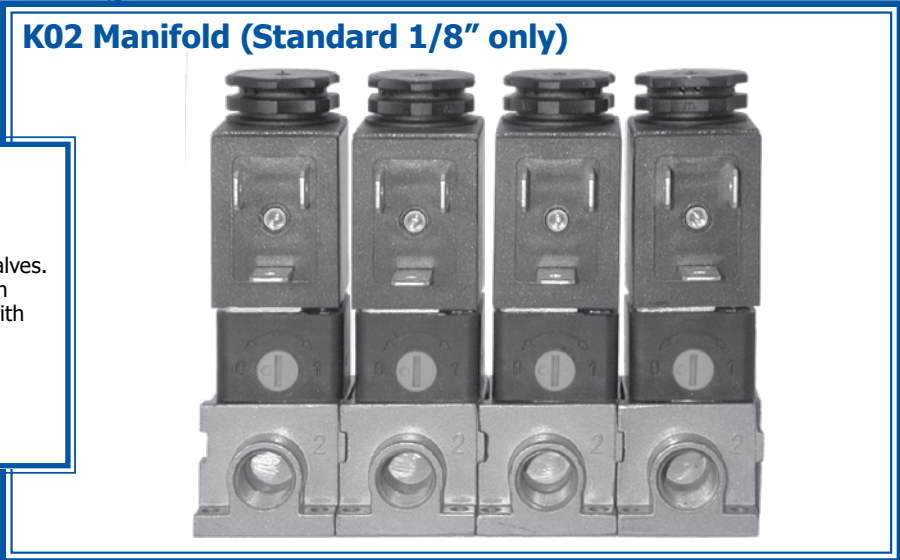
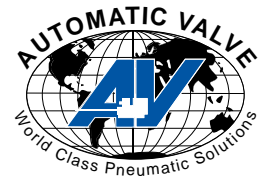

Manifold Model Number

A K02 manifold consists of individual K02 valves. Each Station mounts to the adjacent Station using a single screw and o-ring (included with each individual K02 valve).

See chart below for K02 model numbers.

Shown (right): Quantity 4 K0222JAXR-AA assembled as a manifold

Model Numbers

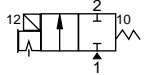
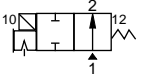
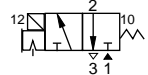
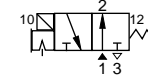
Series	Port Size			Flow l/min (Cv)	2/2		3/2		Materials		Wt Kg (lb)
	1	2	3		Normally Closed	Normally Open	Normally Closed	Normally Open	Body	Seal	
											
K02	1/8	1/8	M5	100 (0.1)	K0222JAXR-**	K0222KAXR-**	K0222GAXR-**	K0222HAXR-**	Aluminum	FPM (FKM)	0,14 (0.3)

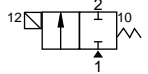
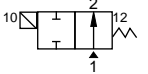
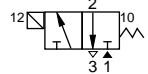
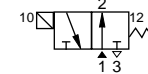
Series	Port Size			Flow l/min (Cv)	2/2		3/2		Materials		Wt Kg (lb)
	1	2	3		Normally Closed	Normally Open	Normally Closed	Normally Open	Body	Seal	
											
K03	1/8	1/8	1/8	200 (0.2)	K0302JABR-**	K0302KABR-**	K0302GABR-**	K0302HABR-**	Aluminum	NBR	0,57 (1.3)
	1/4	1/4	1/4		K0303JABR-**	K0303KABR-**	K0303GABR-**	K0303HABR-**			

** = Coil Voltage Code. Coils also sold separately. Refer to "Electrical Information" at the end of this Section for additional information.

Dimensional Information

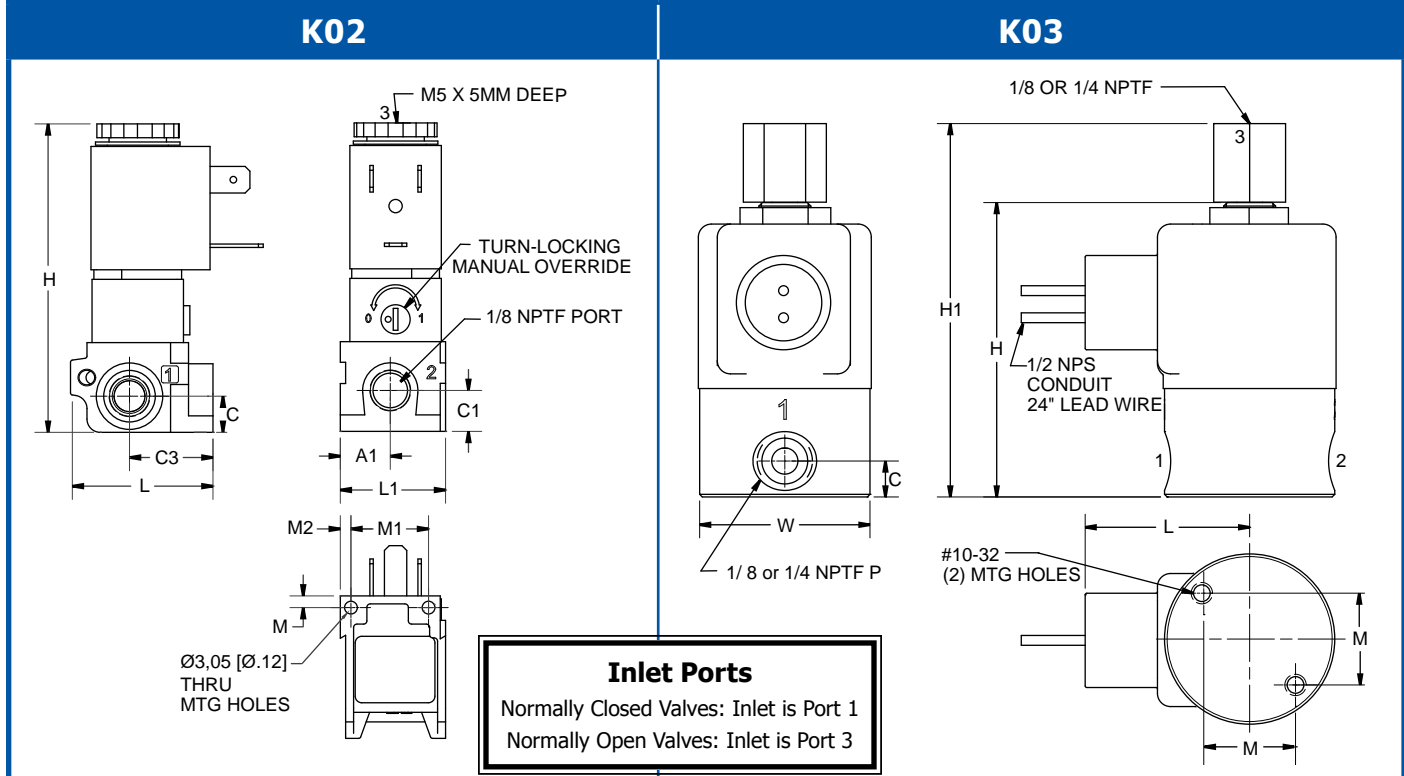

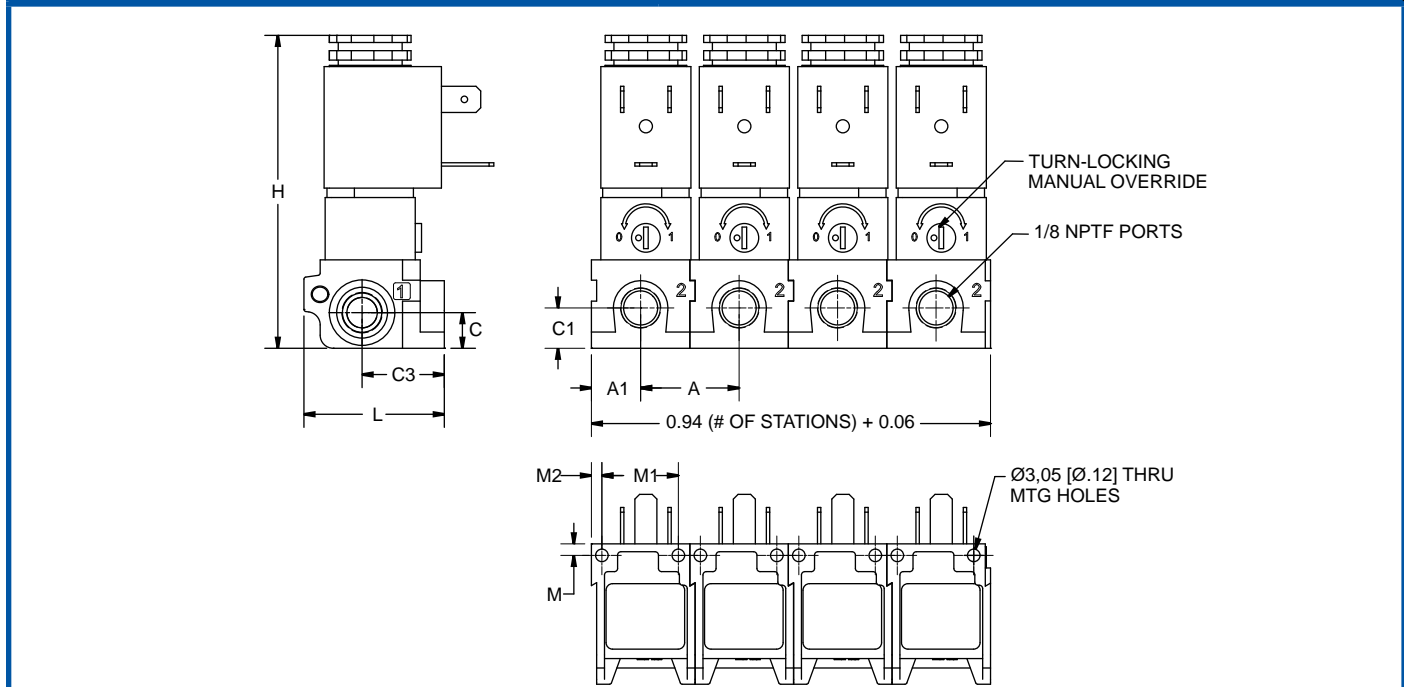

K02 Manifold



Series	A	A1	C	C1	C3	H	H1	L	L1	M	M1	M2	W
K02	23,88 0.94	11,94 0.47	8,64 0.34	9,78 0.39	19,94 0.79	75,87 2.99	-	33,60 1.32	25,15 0.99	2,79 0.11	18,54 0.73	2,54 0.10	-
K03		-	8,64 0.34	-	-	71,37 2.81	90,53 3.56	39,88 1.57	-	22,25 0.88	-	-	41,28 1.63

Units of Measure: Top - mm, Bottom - inches

2/2 
 3/2 

Direct Operated Solenoid Valve Bar Stock & Manifold



K02



K02-004-AA

Manifold



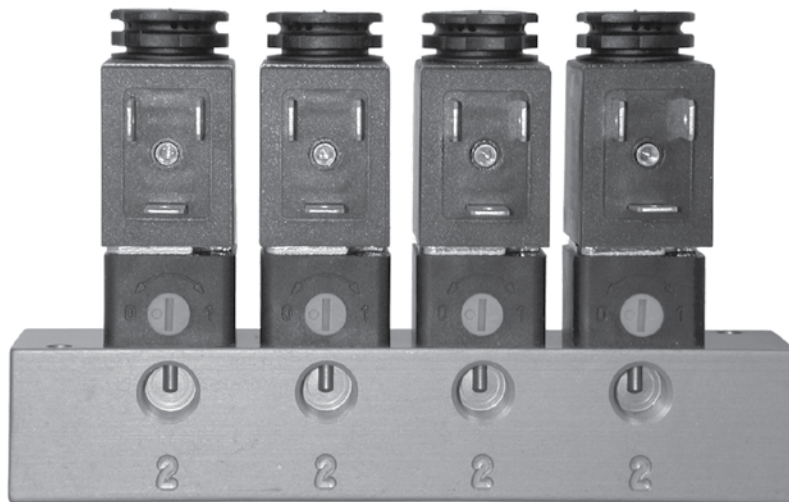

7116-004

4 K02 on 4 Station Manifold

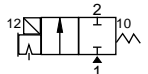
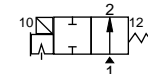
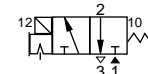

Quantity 4 K0200GAXR-AA on a 7116-004

Model Numbers

Series	Base Type	Port Size			Flow l/min (Cv)	2/2		3/2		Mat'l		Wt Kg (lb)
		1	2	3		Normally Closed	Normally Open	Normally Closed	Normally Open	Body	Seal	
												
K02	none	-	-	M5	100 (0.1)	K0200JAXR-**	K0200KAXR-**	K0200GAXR-**	K0200HAXR-**	Aluminum ²	FKM (FKM)	0,2
	Sub ¹	1/8	1/8			K02-006-**	K02-007-**	K02-004-**	K02-005-**			0,09
	Sub ¹	1/4	1/4			K0223JAXR-**	K0223KAXR-**	K0223GAXR-**	K0223HAXR-**			0,14 (0.3)

** = Coil Voltage Code. Coils also sold separately. Refer to "Electrical Information" at the end of this Section for additional information.

¹ Can not be used on a manifold; order a valve without a base, see K0200*AXR-** valves above.

² Body Available in 303 or 316 Stainless Steel (Bar Stock only). Refer to "Options" at the end of this Section for additional information.

	No. of Stations	Model Number	Ports		Weight kg (lb)	Accessories	
			1	2		Cover Plate	
Base	1	7115-013	1/8	1/8	0,04 (0.09)	-	
		7115-025	1/4	1/4		-	
Manifold*	2	7116-002	1/4	1/8	0,12 (0.26)	A7116-606	
	4	7116-004					0,20 (0.44)
	6	7116-006					0,28 (0.62)
	8	7116-008					0,36 (0.80)

* Seals and Mounting Hardware included.

Dimensional Information

K02 Bar Stock

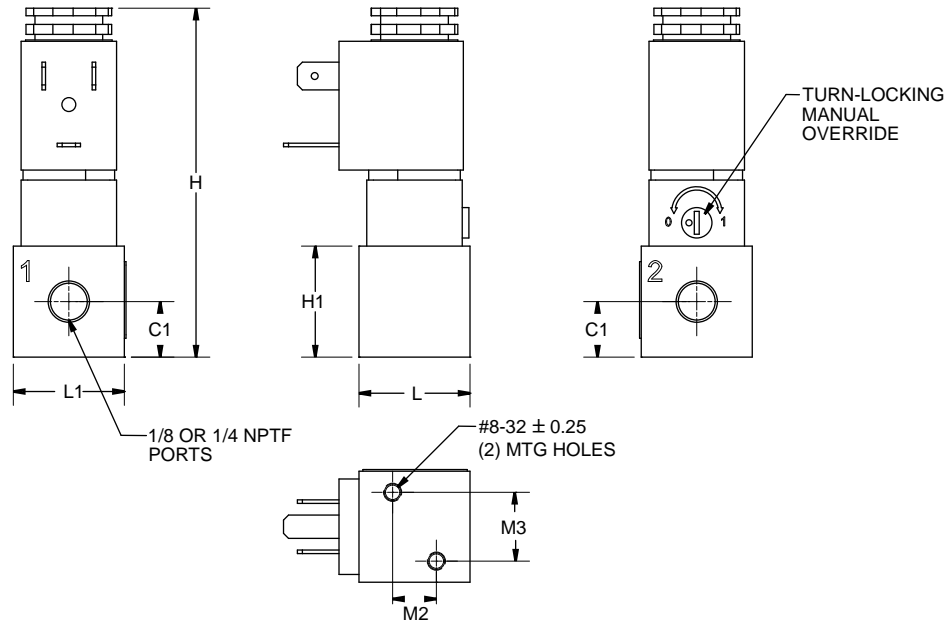

K02 Bar Stock Manifold

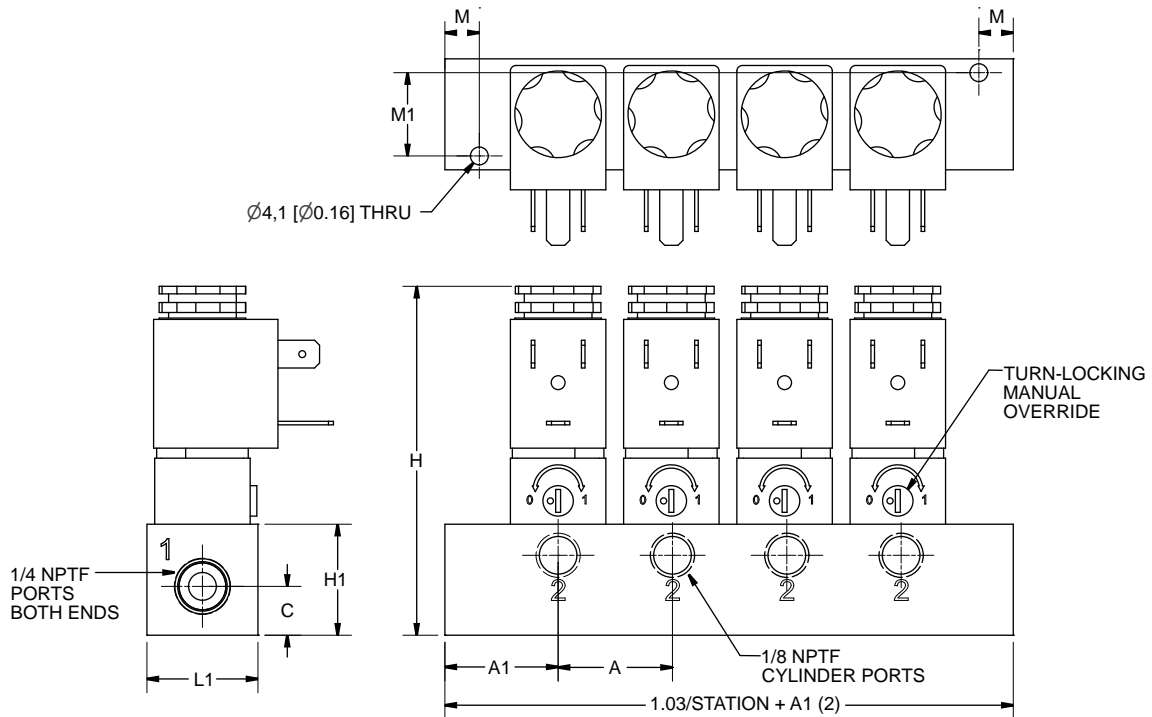

Series	A	A1	C	C1	H	H1	L	L1	M	M1	M2	M3
K02	26,2 1.03	25,9 1.02	11,2 0.44	12,7 0.50	79,8 3.14	25,4 1.00	25,4 1.00	25,4 1.00	7,87 0.31	19,1 0.75	9,91 0.39	15,7 0.62

Units of Measure: Top - mm, Bottom - inches

2/2

3/2

Direct Operated Solenoid Valve Manual & Accessories

K08

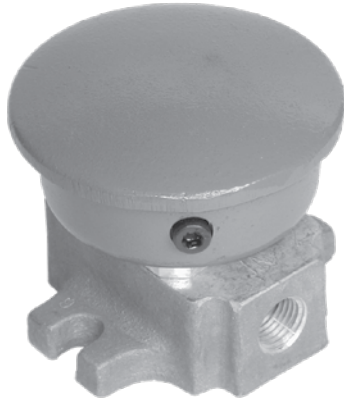

260A-2G

Guard

**Part Number
6098**

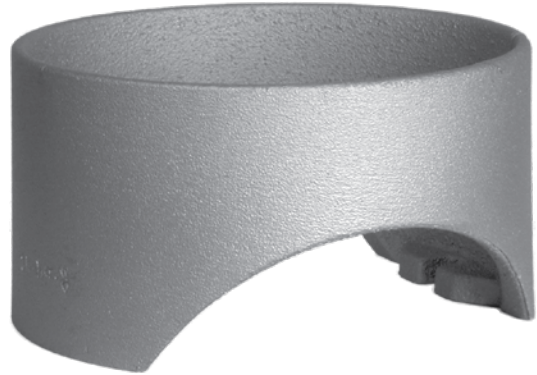

Air Pressure	Hand Force
20 lb	4 lb
40 lb	6 lb
60 lb	8 lb
80 lb	9 lb
100 lb	10 lb

Model Numbers

Series	Port Size	Port Loc'n	Flow l/min (Cv)	2/2	3/2	Materials		Wt Kg (lb)
						Body	Seal	
K08	1/4	Side	790 (0.8)	260A-2	360A-2	Aluminum	NBR	0,4 (0,9)

Dimensional Information

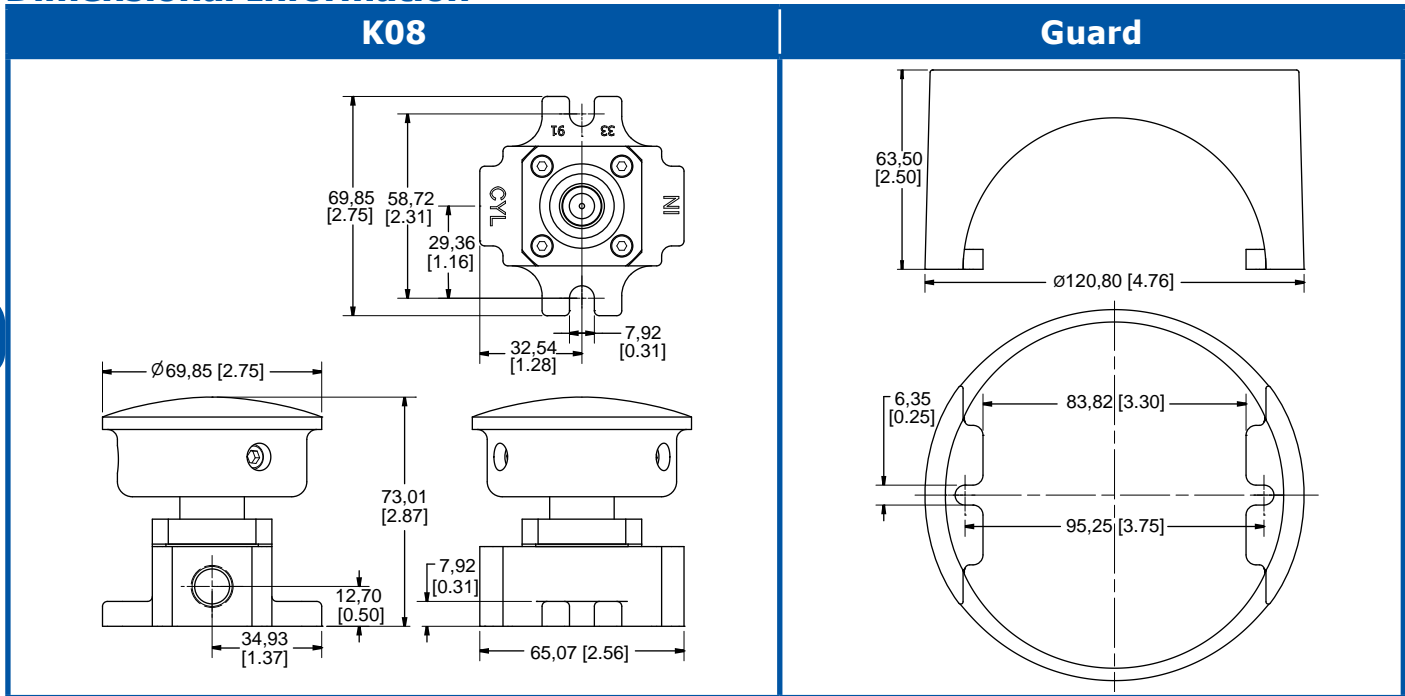

K08 Accessories

Part Number	Description
6098	Guard Ring type shield used to prevent inadvertant valve actuation.



Direct Operated Solenoid Valve Options

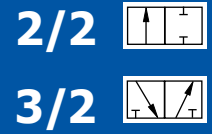

K02 Options (Add the suffix to the end of the model number in alpha-numeric order)

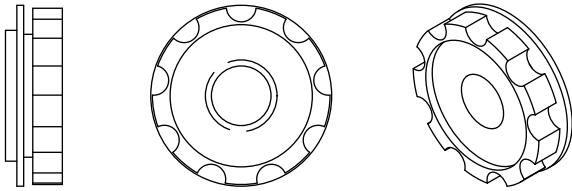
Suffix	Option	Description
C	Conduit Coil	Refer to the "Electrical Information" page in this section for details.
CT	Conduit Coil High Temperature	Refer to the "Electrical Information" page in this section for details.
G	Coil With 18" Leads	Refer to the "Electrical Information" page in this section for details.
O	Exhaust Nut	Open-top retainer nut for access to solenoid stem (K02 Only). 
S	303 Stainless Steel	303 Stainless Steel body, all other external parts corrosion resistant; for corrosive environment applications. (K02 Bar Stock Only)
SS	316 Stainless Steel	316 Stainless Steel body, all other external parts corrosion resistant; for corrosive environment applications. (K02 Bar Stock Only)
Y	Explosion-Proof Coil (CSA, FM)	Refer to the "Electrical Information" page in this section for details.
Z	Explosion-Proof Coil (Atex, PTB)	Refer to the "Electrical Information" page in this section for details.
2	Extended Turn-Locking Override	Solenoid cap provides an extended override that is turned to lock in the "on" position.
4	No Override	Solenoid cap does not provide a manual override.

K03 Options (Add the suffix to the end of the model number in alpha-numeric order)

Suffix	Option	Description
A	Fluoroelastomer Seals	For applications where fluid media or ambient conditions are not compatible with nitrile seals. <i>Note: Fluorocarbon seals do not increase the effective temperature range of the valve. For high temperature applications, consult the factory.</i>
T	High Temperature Coil	Refer to the "Electrical Information" page in this section for details.

K08 Options (Add the suffix to the end of the model number in alpha-numeric order)









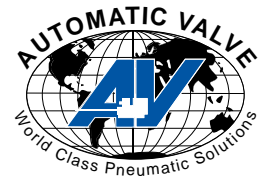





Suffix	Option	Description
A	Fluoroelastomer Seals	For applications where fluid media or ambient conditions are not compatible with nitrile seals. <i>Note: Fluorocarbon seals do not increase the effective temperature range of the valve. For high temperature applications, consult the factory.</i>
B	Blue	Button is Blue
G	Green	Button is Green
R	Red	Button is Red

2/2 

3/2 

Direct Operated Solenoid Valve Configuration Example



Valve With W-Solenoid Cap	+	Coil	=	Valve With Coil
 K0223GAXR	+	 NEMA 4x with DIN 43650 Form B Connection 7019-9**	=	 K0223GAXR-**
 K0223GAXR	+	 NEMA 4x with 18" Leads 7019-9**G	=	 K0223GAXR-**G
 K0223GAXR	+	 NEMA 4x 1/2" Conduit with 30" Leads 7019-9**C	=	 K0223GAXR-**C
 K0223GAXR	+	 Explosion-Proof 1/2" Conduit with 24" Leads 7019-9**Y	=	 K0223GAXR-**Y
 K0223GAXR	+	 ATEX Explosion-Proof with 39" Cable 7152-9**	=	 K0223GAXR-**Z

G



Direct Operated Solenoid Valve Electrical Information

2/2

3/2

Direct Operated Solenoid Valves

Part Numbers

Description	Series	Operator Type	Instructions	Wt. Kg (lb)	Coil Part Number **=Voltage
Weather-Proof DIN 43650 Industrial Form B Connection NEMA 4X	K02	X	Order coil separately (specify voltage code from below)	0,05 (0.12)	7019-9**
Weather-Proof 18" Leads NEMA 4X	K02	X	Order coil separately (specify voltage code from below)	0,05 (0.12)	7019-9**G
Weather-Proof 1/2" Conduit with 30" Leads NEMA 4X	K02	X	Order coil separately (specify voltage code from below)	0,05 (0.12)	7019-9**C 7019-9**CT (high temp 82°C max)
Explosion-Proof 1/2" Conduit with 24" Leads CSA & FM Approved CL. I; Zone 1 Ex m II T4; AEx m II CL. I; Div.1; GR. A, B, C, D CL. II; GR. E, F, G CL. III T4 Ta=-20°C to +60°C NEMA 4, 4X, 7C, 7D, 9	K02	X	Order coil separately (specify voltage code from below)	0,20 (0.44)	7019-9**Y
Explosion-Proof 3m Cable & Strain Relief Ex m II T5 PTB 03 ATEX2018 X Ex II 2 G EEx m II T5 Ex II 2 D IP65 T95°C	K02	Z	Order coil separately (specify voltage code from below)	0,36 (0.78)	7152-9**
Weather-Proof 1/2" Conduit with 24" Leads NEMA 4x	K03	B	Coil included (specify voltage code from below)	0,27 (0.61)	A5983-**F
Explosioin-Proof 1/2" Conduit with 24" Leads CL. I; Div.2; GR. A & B. CL. I; Div.1; GR. C & D CL. II; Div.1; GR. E, F, G	K03	D	Coil included (specify voltage code from below)	0,48 (1.05)	A6454-**F

Voltage Codes (Lower wattage options available, consult factory)

K02	Current (Amps)				Resistance (OHMS @ 25°C)				Power (AC=VA, DC=Watts)			
	Inrush		Holding		X		Z		X		Z	
	Operator Type:	X	Z	X	Z	X	Z	X	Z	X	Z	
** Code	Volt. +/-10%	NEMA	Atex	NEMA	Atex	NEMA	Atex	NEMA	Atex	NEMA	Atex	
	4 7,9&Z	4 7,9		4 7,9		4 7,9		4 7,9		4 7,9		
DA	24/50 24/60	-	.36	-	.24	-	-	32	-	6.9	-	
AA	120/50 120/60	120/60	.08 .10	-	.05 .05	-	-	840 530	-	6.9 6.5	-	
AB	230/50 230/60	240/60	.04 .05	-	.03 .03	-	-	3310 2345	-	6.4 6.8	-	
DA	12VDC	12VDC	.38 .38	-	.38 .38	-	-	32 32	-	4.8 4.5	-	
DB	24VDC	24VDC	.20 .19	.05	.20 .19	.05	-	121 128 275	-	4.8 4.5 1.6	-	
AB	125VDC	-	.04	-	.04	-	-	3310	-	5.9	-	

K03	Current (Amps)				Resist. (OHMS @ 25°C)				Power (Watts)			
	Inrush		Holding		B		D		B		D	
	Operator Type:	B	D	B	D	B	D	B	D	B	D	
** Code	Volt. ±10%	NEMA										
	4 7,9	4 7,9	4 7,9	4 7,9	4 7,9	4 7,9	4 7,9	4 7,9	4 7,9	4 7,9	4 7,9	
AA	100/50 120/60	120/60	.26 .26	.16 .16	156 156	156	8.7 7.3					
AB	208/50 240/60	240/60	.13 .13	.08 .08	636 636	636	8.7 7.3					
DA	12VDC	12VDC	.80 .80	.80 .80	15.1 15.1	15.1	9.5 9.5					
DB	24VDC	24VDC	.39 .39	.39 .39	62 62	62	9.5 9.5					

Connectors (Not polarity dependent)

DIN 43650 Industrial Form B	Maximum Cable Diameter: 9mm (0.35")		Strain Relief with Light		1/2" Conduit without Cord	Molded with 6' Cord	Strain Relief with Light & 6' Cord	
Type	Strain Relief without Cord	100-240 AC 48-120 DC	6-48 AC/DC	1/2" Conduit without Cord	Molded with 6' Cord	100-240 AC 48-120 DC	6-48 AC/DC	
Part Number	7020-001	7020-AA	7020-DB	7039-001	7020-006	7094-006	7094-007	

AV AUTOMATIC VALVE

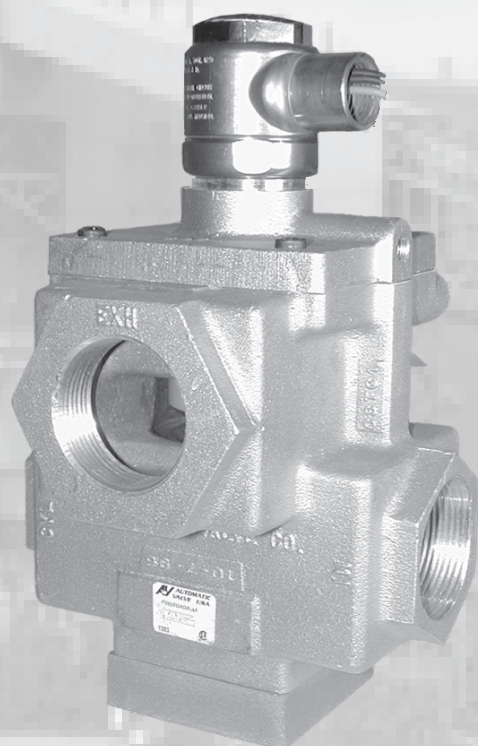
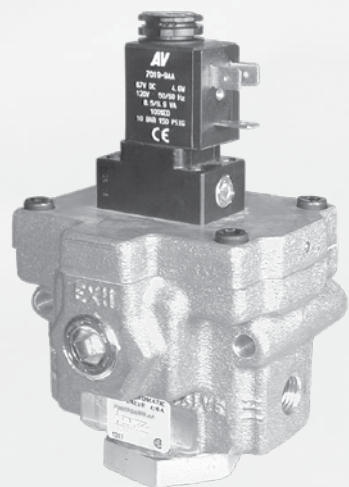

Pilot Inline Poppet Valves

	Page
Design Features	H2
Specifications	H3
Model Number	H3
Standard Solenoid	H4-H7
Air Pilot	H8-H10
Options	H11
Configuration Example	H12
Electrical Information	H13
Service Information	H14

2/2 

3/2 

Direct Inline Poppet Valves

Design Features

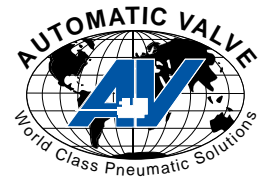

Valves

- Reliable: used world-wide in power plant applications.
- High flow design with a short stroke for fast response.
- Front or rear mounting.
- Flow from 3 to 34 Cv.
- Specific application needs? Consult the factory. We will build it for you.

Tapered Cush-N-Seal

- Molded from superior, tough, Carboxylated Nitrile. Provides five times the abrasion resistance and service life of standard Buna-N (NBR) seals.
- Cushion design increases life.
- Self-cleaning, cushioned poppet allows for quieter operation.



Solenoid ... Guaranteed Against Burnout

- Three-way pilot uses full air line pressure to shift the valve.
- Pilot is internally supplied when the pressure at port one is 35 to 150 PSIG (240 to 1030 kPa).
- Coil is hermetically sealed as an integral watertight molded unit.
- Intrinsically-safe and explosion-proof versions available.
- Push Non-Locking Override is standard. (Extended Turn and Turn-Locking available.)



Products Certified To:

- CSA - (C22.2 and UL STD 429)
- Factory Mutual - Explosion Proof Environments
- ATEX - Explosion Proof Environments
- CE - EMF and Low Voltage Directives

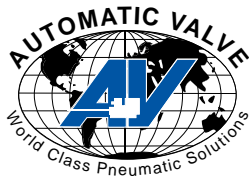

Pilot Inline Poppet Valves Specs & Model Numbers

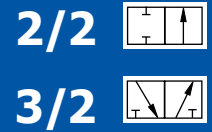

Specifications

Valve Operation		Valve Operation			
 DE-ENERGIZED	 ENERGIZED	2/2 Normally Closed De-Energized: Blocks Pressure at Port 1 Energized: Pressure from Port 1 to Port 2	 DE-ENERGIZED	 ENERGIZED	3/2 Normally Closed De-Energized: Exhausts Pressure from Port 2 to Port 3 Blocks Pressure at Port 1 Energized: Pressure from Port 1 to Port 2
 DE-ENERGIZED	 ENERGIZED	2/2 Normally Open De-Energized: Pressure from Port 1 to Port 2 Energized: Blocks Pressure at Port 1	 DE-ENERGIZED	 ENERGIZED	3/2 Normally Open De-Energized: Pressure from Port 1 to Port 2 Energized: Exhausts Pressure from Port 2 to Port 3 Blocks Pressure at Port 1
Operating Temperatures 	Operator		Treated Buna-N Seals (Treated NBR, Standard)	Fluoroelastomer Seals (FPM (FKM), Option A)	
	Solenoid Pilot	Standard	-18°C to +50°C (0°F to +123°F)	-18°C to +50°C (0°F to +123°F)	
		High Temp (Option CT or T)	-18°C to +82°C (0°F to +180°F)	-18°C to +82°C (0°F to +180°F)	
Air Pilot	Standard	-18°C to +82°C (0°F to +180°F)	-18°C to +121°C (0°F to +250°F)		
Operating Pressures 	Operator		Inlet Port	External Pilot Port	
	Solenoid Pilot	Standard	240 - 1030 kPa (35 - 150 PSIG)	-	
		External (Option B)	0 - 1030 kPa (0 - 150 PSIG)	240 - 1030 kPa (35 - 150 PSIG) and ≥ inlet	
		Vacuum Spring (Option J)	Vacuum	240 - 1030 kPa (35 - 150 PSIG) and ≥ inlet	
	Air Pilot	Standard	0 - 1720 kPa (0 - 250 PSIG)	Min. 240 kPa (35 PSIG) and ≥ inlet	
Vacuum Spring (Option J)		Vacuum	240 - 1030 kPa (35 - 150 PSIG) and ≥ inlet		
Filtration & Lubrication	Media - Air Or Inert Gas				
	Air Line Lubrication of Automatic Valve products is not required, but is recommended to maximize service life. Oils should be compatible with seal material, have an ISO 32 viscosity, and have an aniline range between 82°C (180°F) and 99°C (210°F). Filter to 50 microns or better. For temperatures below 40°F, air must be dry to prevent formation of ice. Refer to the Maintenance section of this catalog for recommended lubricants.				

Model Numbers

Series	Base Type	Port Size	Body Type	Body Design	Operator 1	Operator 2	Voltage ¹	Options*
P06	0 Inline	3 1/4	G 3 Way NC	A Single	A Air Pilot W Weather-Proof Solenoid	R 2 Position Spring	-AA 110/50, 120/60 -AB 220/50, 240/60, 125VDC -DA 22/50, 24/60, 12VDC -DB 24VDC	A Fluoroelastomer Seals
		4 3/8	H 3 Way NO					B External Pilot Connection
		5 1/2	J 2 Way NC K 2 Way NO					C Conduit Coil CT Conduit Coil High Temperature G 18" Flying Leads J Vacuum Spring L Low Watt Coil (2.5 Watts) (P06,P14) LL Lowest Watt Coil (0.7 Watts) (P06,P14) T High Temperature Coil (P36) Y Explosion-Proof Coil (CSA, FM) (P06,P14) Z Explosion-Proof Coil (ATEX, PTB) (P06,P14)
P14	5 1/2 6 3/4 7 1	7 1	8 1 1/4 9 1 1/2	A Air Pilot B Weather-Proof Solenoid D Explosion-Proof Solenoid	1 Push Turn-Locking Override 2 Extended Turn-Locking Override			

* Not all Options are available for all models. Refer to "Options" at the end of this Section for additional information.

¹ Consult the Factory for additional voltages.

2/2

3/2

Pilot Inline Poppet Valves Standard Solenoid

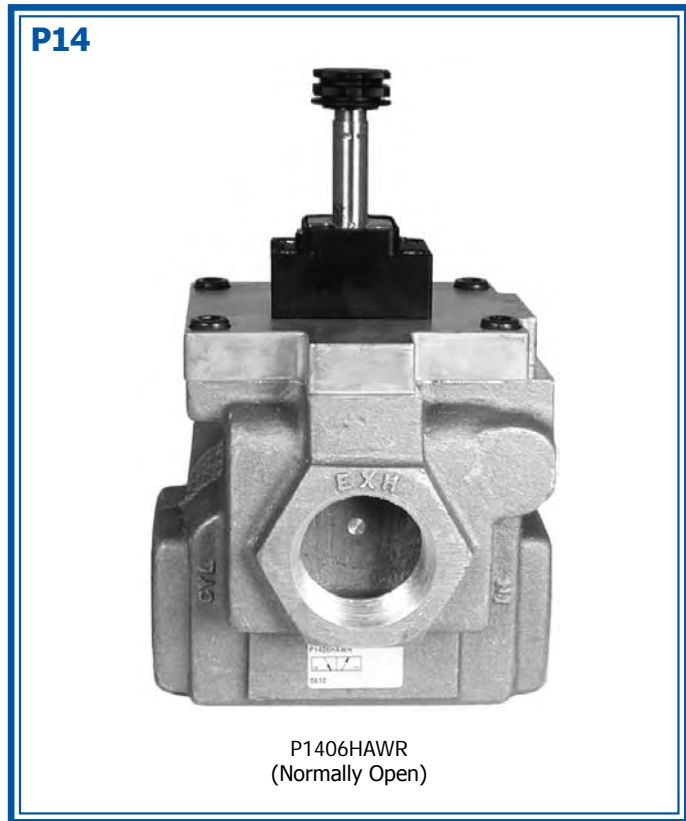
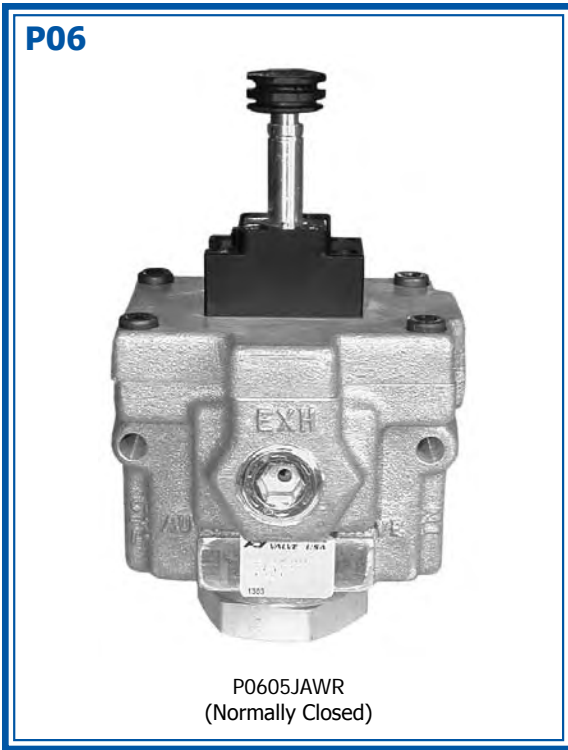

Model Numbers

Series	Port Size		Flow l/min (Cv)	2/2		3/2		Materials		Wt Kg (lb)
	1,2	3		Normally Closed	Normally Open	Normally Closed	Normally Open	Body	Seal	
P06	1/4	1/2	3150 (3.2)	P0603JAWR-**	P0603KAWR-**	P0603GAWR-**	P0603HAWR-**	Aluminum	NBR	1,8 (4.0)
	3/8	1/2	3840 (3.9)	P0604JAWR-**	P0604KAWR-**	P0604GAWR-**	P0604HAWR-**			
	1/2	1/2	5410 (5.5)	P0605JAWR-**	P0605KAWR-**	P0605GAWR-**	P0605HAWR-**			
P14	1/2	1	8170 (8.3)	P1405JAWR-**	P1405KAWR-**	P1405GAWR-**	P1405HAWR-**			2,3 (5.1)
	3/4	1	11120 (11.3)	P1406JAWR-**	P1406KAWR-**	P1406GAWR-**	P1406HAWR-**			
	1	1	13580 (13.8)	P1407JAWR-**	P1407KAWR-**	P1407GAWR-**	P1407HAWR-**			

** = Coil Voltage Code. Coils also sold separately. Refer to "Electrical Information" at the end of this Section for additional information.

Pilot Inline Poppet Valves Standard Solenoid

2/2

3/2

P36 - Weather-Proof



P3609GABR-AA

P36 - Explosion-Proof



P3609GADR-DB

Model Numbers

Series	Operator	Port Size		Flow l/min (Cv)	2/2		3/2		Mat'l		Wt Kg (lb)
		1,2	3		Normally Closed	Normally Open	Normally Closed	Normally Open	Body	Seal	
P36	Weather-Proof	1	1 1/2	29030 (29.5)	P3607JABR-**	P3607KABR-**	P3607GABR-**	P3607HABR-**	Aluminum	NBR	4,2 (9.1)
		1 1/4	1 1/2	31290 (31.8)	P3608JABR-**	P3608KABR-**	P3608GABR-**	P3608HABR-**			
		1 1/2	1 1/2	33260 (33.8)	P3609JABR-**	P3609KABR-**	P3609GABR-**	P3609HABR-**			
	Explosion-Proof	1	1 1/2	29030 (29.5)	P3607JADR-**	P3607KADR-**	P3607GADR-**	P3607HADR-**			4,2 (9.1)
		1 1/4	1 1/2	31290 (31.8)	P3608JADR-**	P3608KADR-**	P3608GADR-**	P3608HADR-**			
		1 1/2	1 1/2	33260 (33.8)	P3609JADR-**	P3609KADR-**	P3609GADR-**	P3609HADR-**			

** = Coil Voltage Code. Coils also sold separately. Refer to "Electrical Information" at the end of this Section for additional information.

2/2

3/2

Pilot Inline Poppet Valves

Standard Solenoid

Dimensional Information

P06

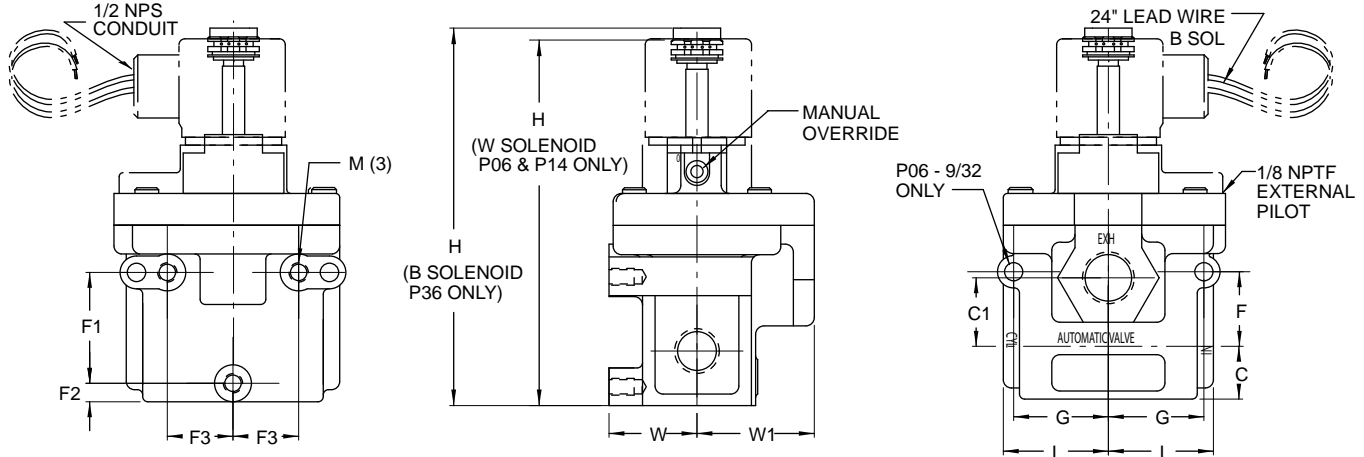

Shown: P06 Normally Open

P14

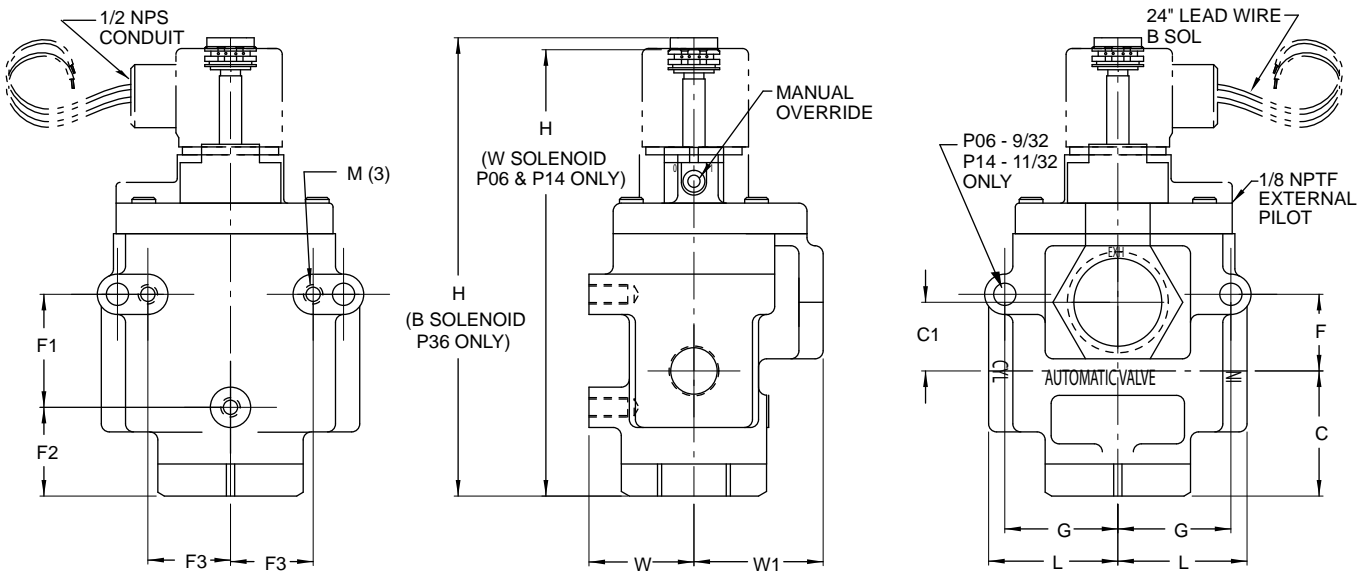

Shown: P14 Normally Closed

Series		C	C1	F	F1	F2	F3	G	H	L	M	W	W1
P06	NC	32,5 1.28	20,6 0.81	20,6 0.81	42,9 1.68	17,3 0.68	25,4 1.00	37,3 1.47	145 5.72	41,3 1.62	1/4-20	33,3 1.31	44,5 1.75
	NO	20,6 0.81	27,0 1.06	29,5 1.16	42,9 1.68	7,2 .28	25,4 1.00	37,3 1.47	140 5.51	41,3 1.62	1/4-20	33,3 1.31	44,5 1.75
P14	NC	49,3 1.94	27,0 1.06	30,2 1.19	44,5 1.75	34,9 1.37	33,3 1.31	44,5 1.75	175 6.88	50,8 2.00	5/16-18	41,3 1.62	50,8 2.00
	NO	22,1 0.87	27,0 1.06	-	44,5 1.75	7,9 0.31	33,3 1.31	-	159 6.26	50,8 2.00	5/16-18	41,3 1.62	50,8 2.00

Units of Measure: Top - mm, Bottom - inches

Dimensional Information

P36 Normally Closed (NC)

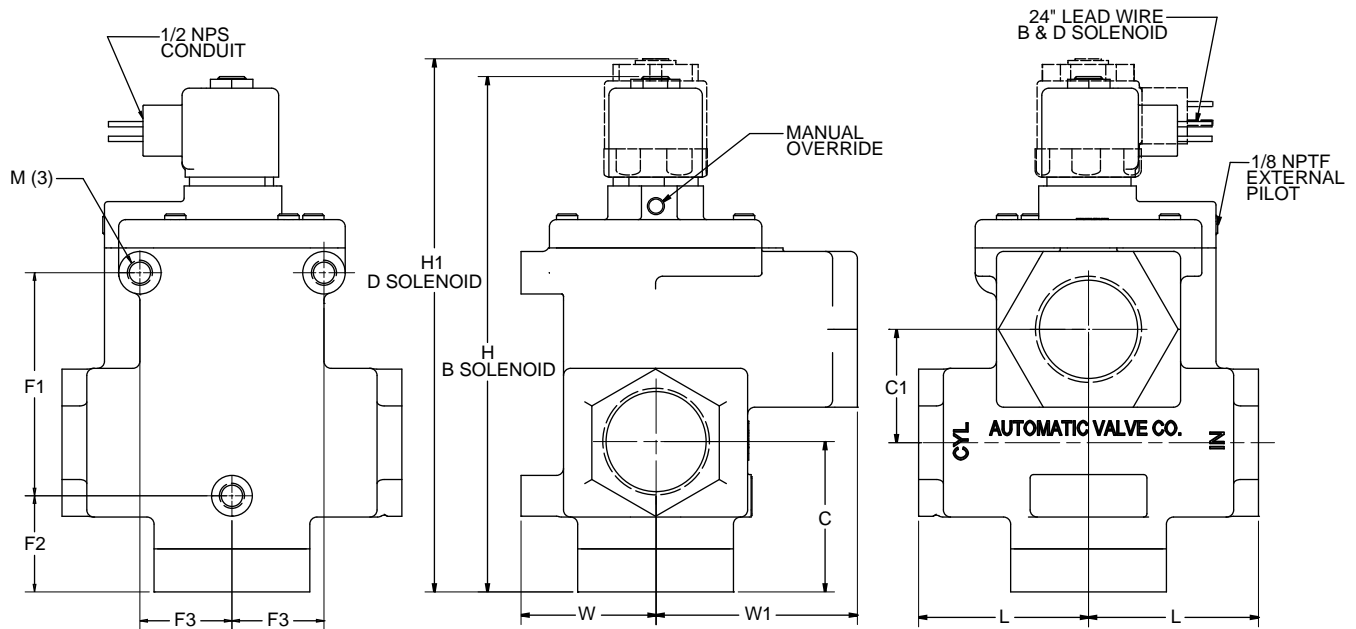

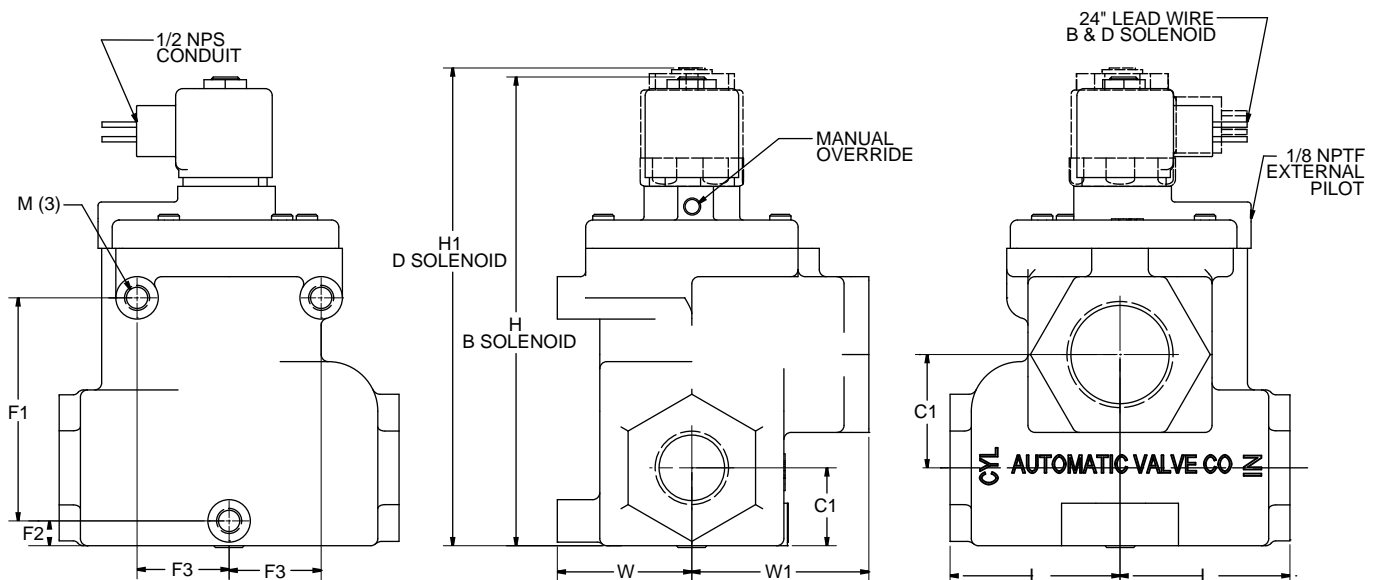

P36 Normally Open (NO)



Series		C	C1	F1	F2	F3	H	H1	L	M	W	W1
P36	NC	67,5 2.66	50,8 2.00	100 3.94	43,7 1.72	41,3 1.62	229 9.00	239 9.39	76,2 3.00	3/8-16	60,5 2.38	79,2 3.12
	NO	35,1 1.38	50,8 2.00	100 3.94	11,1 0.44	41,3 1.62	210 8.25	220 8.64	76,2 3.00	3/8-16	60,5 2.38	79,2 3.12

Units of Measure: Top - mm, Bottom - inches

2/2 

3/2 

Pilot Inline Poppet Valves

Air Pilot

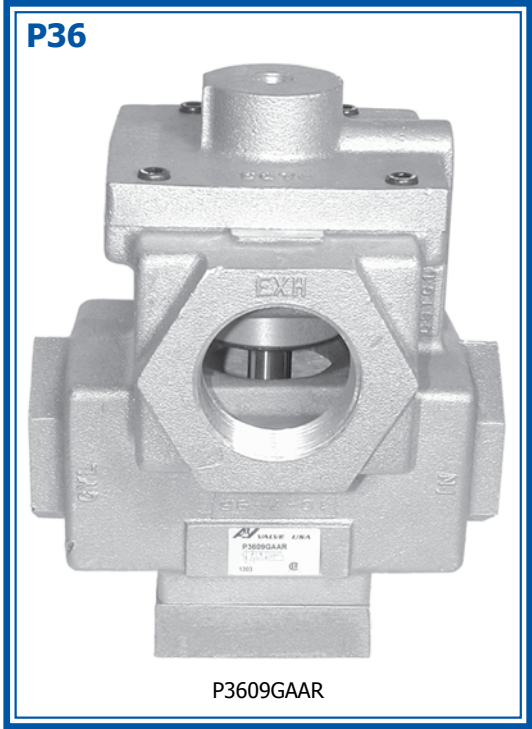

Model Numbers

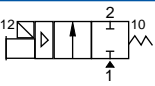
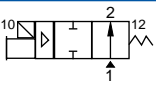
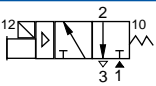
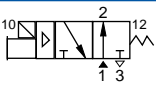
Series	Port Size		Flow l/min (Cv)	2/2		3/2		Materials		Wt Kg (lb)
	1,2	3		Normally Closed	Normally Open	Normally Closed	Normally Open	Body	Seal	
										
P06	1/4	1/2	3150 (3.2)	P0603JAAR	P0603KAAR	P0603GAAR	P0603HAAR	Aluminum	NBR	0,9 (2.0)
	3/8	1/2	3840 (3.9)	P0604JAAR	P0604KAAR	P0604GAAR	P0604HAAR			
	1/2	1/2	5410 (5.5)	P0605JAAR	P0605KAAR	P0605GAAR	P0605HAAR			
P14	1/2	1	8170 (8.3)	P1405JAAR	P1405KAAR	P1405GAAR	P1405HAAR			1,4 (3.0)
	3/4	1	11120 (11.3)	P1406JAAR	P1406KAAR	P1406GAAR	P1406HAAR			
	1	1	13580 (13.8)	P1407JAAR	P1407KAAR	P1407GAAR	P1407HAAR			
P36	1	1 1/2	29030 (29.5)	P3607JAAR	P3607KAAR	P3607GAAR	P3607HAAR			3,2 (7.0)
	1 1/4	1 1/2	31290 (31.8)	P3608JAAR	P3608KAAR	P3608GAAR	P3608HAAR			
	1 1/2	1 1/2	33260 (33.8)	P3609JAAR	P3609KAAR	P3609GAAR	P3609HAAR			

H

Dimensional Information

P06

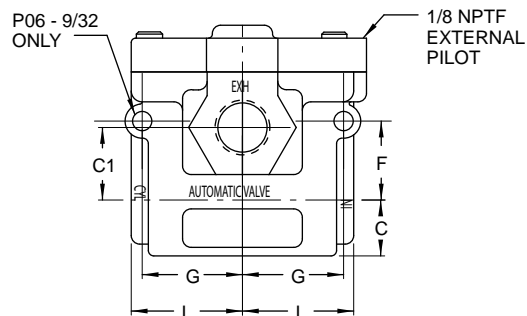
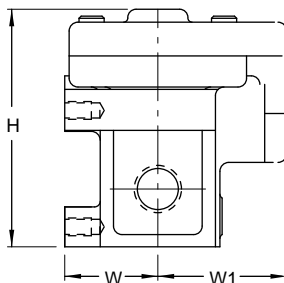
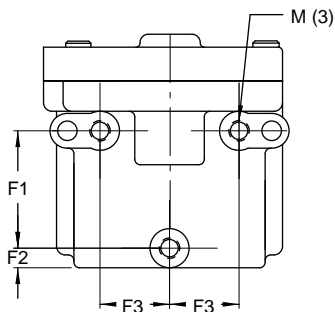

Shown: P06 Normally Open

P14

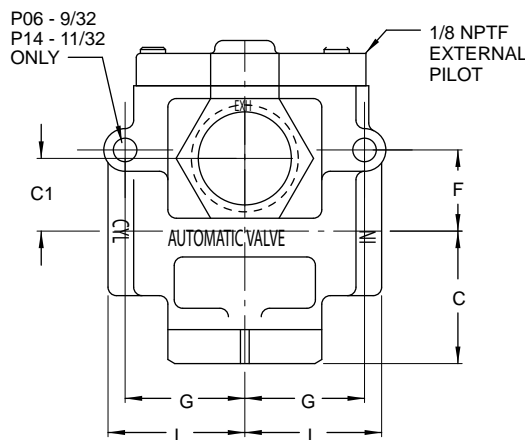
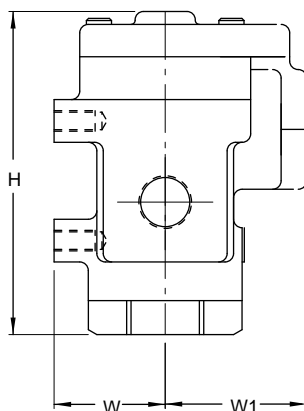
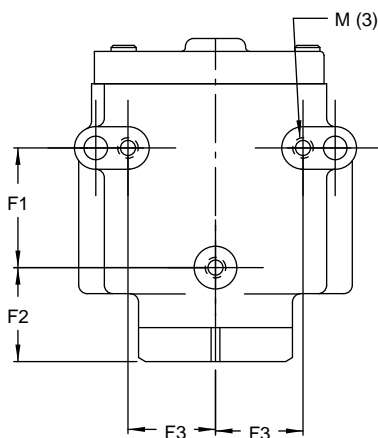

Shown: P14 Normally Closed

Series		C	C1	F	F1	F2	F3	G	H	L	M	W	W1
P06	NC	32,5 1.28	20,6 0.81	20,6 0.81	42,9 1.68	17,3 0.68	25,4 1.00	37,3 1.47	91,3 3.59	41,3 1.62	1/4-20	33,3 1.31	44,5 1.75
	NO	20,6 0.81	27,0 1.06	29,5 1.16	42,9 1.68	7,2 0.28	25,4 1.00	37,3 1.47	85,8 3.38	41,3 1.62	1/4-20	33,3 1.31	44,5 1.75
P14	NC	49,3 1.94	27,0 1.06	30,2 1.19	44,5 1.75	34,9 1.37	33,3 1.31	44,5 1.75	121 4.75	50,8 2.00	5/16-18	41,3 1.62	50,8 2.00
	NO	22,1 0.87	27,0 1.06	-	44,5 1.75	7,9 0.31	33,3 1.31	-	105 4.13	50,8 2.00	5/16-18	41,3 1.62	50,8 2.00

Units of Measure: Top - mm, Bottom - inches

2/2

3/2

Pilot Inline Poppet Valves

Air Pilot

Dimensional Information

P36 Normally Closed (NC)

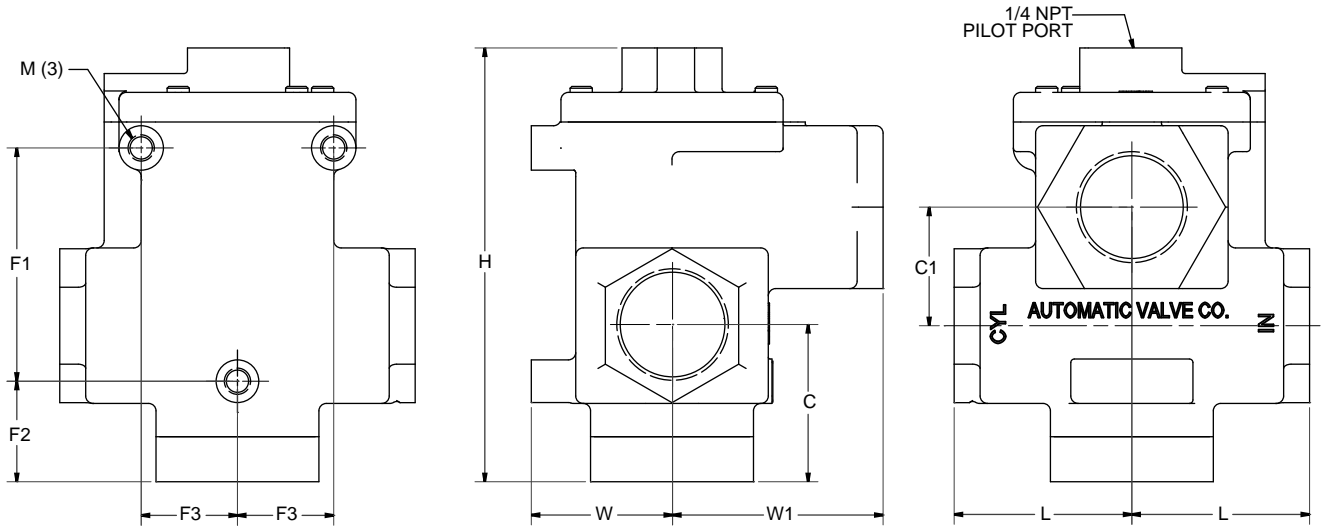

P36 Normally Open (NO)

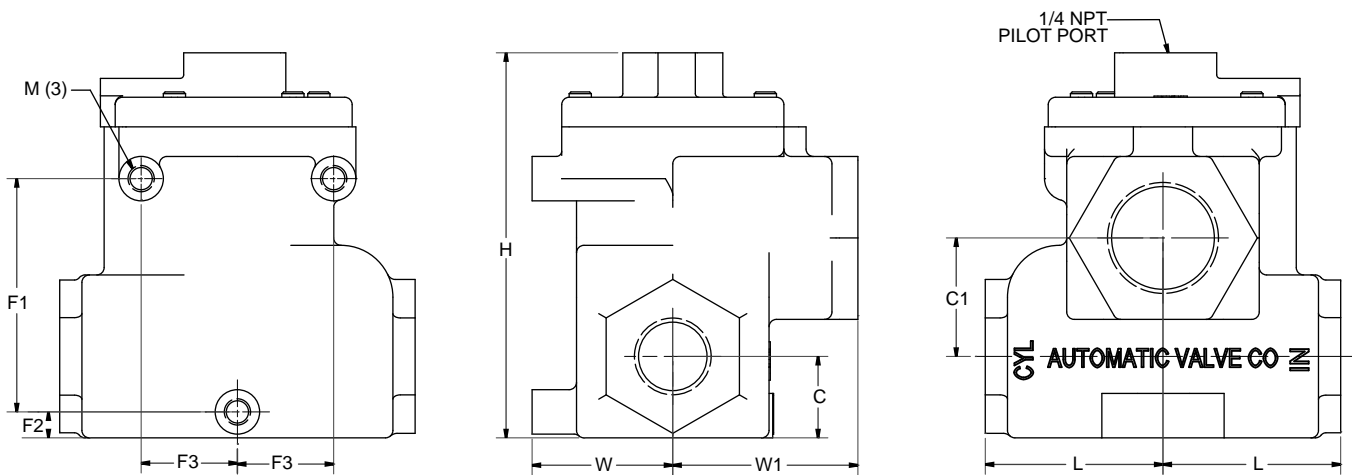

Series		C	C1	F1	F2	F3	H	L	M	W	W1
P36	NC	67,5 2.66	50,8 2.00	100 3.94	43,7 1.72	41,3 1.62	186 7.32	76,2 3.00	3/8-16	60,5 2.38	79,2 3.12
	NO	35,1 1.38	50,8 2.00	100 3.94	11,1 0.44	41,3 1.62	165 6.50	76,2 3.00	3/8-16	60,5 2.38	79,2 3.12

Units of Measure: Top - mm, Bottom - inches

Options (Add the suffix to the end of the model number in alpha-numeric order)









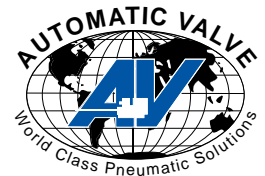

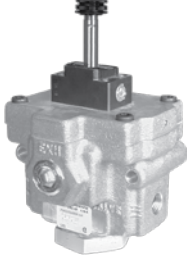



Suffix	Option	Description
A	Fluoroelastomer Seals	For applications where fluid media or ambient conditions are not compatible with nitrile seals. <i>Note: Fluorocarbon seals do not increase the effective temperature range of the valve. For high temperature applications, consult the factory.</i>
B	External Pilot	For solenoid applications where the pressure to port one is less than 2 BAR (35 PSIG). See example below for field conversion.
		<p align="center">Field Conversion for P06 & P14 Valves (W Solenoids)</p> <ul style="list-style-type: none"> Remove solenoid and cap from the valve body. Remove gasket from bottom of W cap. Rotate the gasket 180° so that the internal pilot hole in the valve body is covered by the gasket. Reposition on bottom of cap. Refasten the W cap and solenoid to the valve body. Make sure the gasket completely covers the internal pilot hole before tightening the M3 screws. Torque to 1,02 N-m (9 in-lbs) ±10%. Remove the 1/8 NPTF pipe plug from the cap and make the external pilot connection.
C	Conduit Coil	Refer to the "Electrical Information" page in this section for details.
		Refer to the "Electrical Information" page in this section for details.
CT	Conduit Coil High Temperature	Refer to the "Electrical Information" page in this section for details.
G	Coil With 18" Leads	Refer to the "Electrical Information" page in this section for details.
J	Vacuum Spring	Provides additional reset force when pressure at Port 1 is less then 0 PSIG (0kPa). For solenoid pilot valves, also specify option "B".
L	Low Watt Coil	Power Consumption = 2.5 Watts. Standard as Push Non-Locking Override. Also available with Option 2, Extended Turn-Locking Override.
LL	Lowest Watt Coil	Power Consumption = 0.7 Watts. Standard as Extended Turn-Locking Override.
T	High Temperature Coil	Refer to the "Electrical Information" page in this section for details. (P36 Only)
Y	Explosion-Proof Coil (CSA, FM)	Refer to the "Electrical Information" page in this section for details.
Z	Explosion-Proof Coil (Atex, PTB)	Refer to the "Electrical Information" page in this section for details.
1	Push Turn-Locking Override	Solenoid cap provides an override that is pushed in and turned to actuate & lock in the "on" position.
2	Extended Turn-Locking Override	Solenoid cap provides an extended override that is turned to lock in the "on" position.

2/2 

3/2 

Direct Inline Poppet Valves Configuration Example



Valve With W-Solenoid Cap	+	Coil	=	Valve With Coil
 P0603JAWR	+	 NEMA 4x with DIN 43650 Connection	=	 P0603JAWR-**
 P0603JAWR	+	 NEMA 4x with 18" Leads	=	 P0603JAWR-**G
 P0603JAWR	+	 NEMA 4x 1/2" Conduit with 30" Leads	=	 P0603JAWR-**C
 P0603JAWR	+	 Explosion-Proof 1/2" Conduit with 24" Leads	=	 P0603JAWR-**Y
 P0603JAWR	+	 ATEX Explosion-Proof with 39" Cable	=	 P0603JAWR-**Z



Pilot Inline Poppet Valves

Electrical Information

2/2

3/2

Pilot Inline Poppet Valves

Part Numbers

Description	Series	Operator Type	Instructions	Wt. Kg (lb)	Coil Part Number **=Voltage
Weather-Proof DIN 43650 Industrial Form B Connection NEMA 4X	P06 P14	W	Order coil separately (specify voltage code from below)	0,05 (0.12)	7019-9**
Weather-Proof 18" Leads NEMA 4X	P06 P14	W	Order coil separately (specify voltage code from below)	0,05 (0.12)	7019-9**G
Weather-Proof 1/2" Conduit with 30" Leads NEMA 4X	P06 P14	W	Order coil separately (specify voltage code from below)	0,05 (0.12)	7019-9**C 7019-9**CT (high temp 82°C max)
Explosion-Proof 1/2" Conduit with 24" Leads CSA & FM Approved CL. I; Zone1 ExmIIT4; AExmII CL. I; Div.1; GR. A, B, C, D CL. II; GR. E, F, G CL. III T4 Ta=-20°C to +60°C NEMA 4, 4X, 7C, 7D, 9	P06 P14	W	Order coil separately (specify voltage code from below)	0,20 (0.44)	7019-9**Y
Explosion-Proof 3m Cable & Strain Relief Ex m II T5 PTB 03 ATEX 2018 X Ex II 2 G EEx m II T5 Ex II 2 D IP65 T95°C	P06 P14	Z	Order coil separately (specify voltage code from below)	0,36 (0.78)	7152-9**
Weather-Proof 1/2" Conduit with 24" Leads NEMA 4x	P36	B	Coil included (specify voltage code from below)	0,27 (0.61)	A5983-**F
Explosioin-Proof 1/2" Conduit with 24" Leads CL. I; Div.2; GR. A & B. CL. I; Div.1; GR. C & D CL. II; Div.1; GR. E, F, G	P36	D	Coil included (specify voltage code from below)	0,48 (1.05)	A6454-**F

Voltage Codes (Lower wattage options available, consult factory)

K02	Current (Amps)						Resistance (OHMS @ 25°C)				Power (AC=VA, DC=Watts)				
	Inrush			Holding			W		Z		W		Z		
	W	Z	W	Z	W	Z	W	Z	W	Z	W	Z	W	Z	
Operator Type:	W	Z	W	Z	W	Z	W	Z	W	Z	W	Z	W	Z	
** Code	Volt. +/-10%	NEMA	Atex	NEMA	Atex	NEMA	Atex	NEMA	Atex	NEMA	Atex	NEMA	Atex	NEMA	Atex
	4 7,9&Z	4 7,9		4 7,9		4 7,9		4 7,9		4 7,9		4 7,9		4 7,9	
DA	24/50 24/60	-	.36 - -	.24 - -	- -	32 - -	- -	6.9 - -	- -	- -	- -	- -	- -	- -	- -
AA	120/50 120/60	120/60	.08 .10 -	.05 .05 -	- -	840 530 -	- -	6.9 6.5 -	- -	- -	- -	- -	- -	- -	- -
AB	230/50 230/60	240/60	.04 .05 -	.03 .03 -	- -	3310 2345 -	- -	6.4 6.8 -	- -	- -	- -	- -	- -	- -	- -
DA	12VDC	12VDC	.38 .38 -	.38 .38 -	- -	32 32 -	- -	4.8 4.5 -	- -	- -	- -	- -	- -	- -	- -
DB	24VDC	24VDC	.20 .19 .05	.20 .19 .05	- -	121 128 275	- -	4.8 4.5 1.6	- -	- -	- -	- -	- -	- -	- -
AB	125VDC	-	.04 - -	.04 - -	- -	3310 - -	- -	5.9 - -	- -	- -	- -	- -	- -	- -	- -

P36	Current (Amps)						Resist. (OHMS @ 25°C)				Power (Watts)			
	Inrush			Holding			B		D		B		D	
	B	D	B	D	B	D	B	D	B	D	B	D	B	D
Operator Type:	B	D	B	D	B	D	B	D	B	D	B	D	B	D
** Code	Volt. ±10%	NEMA												
	4 7,9	4 7,9	4 7,9	4 7,9	4 7,9	4 7,9	4 7,9	4 7,9	4 7,9	4 7,9	4 7,9	4 7,9	4 7,9	4 7,9
AA	100/50 120/60	120/60	.26 .26	.16 .16	156 156	156 156	8.7 7.3	8.7 7.3	- -	- -	- -	- -	- -	- -
AB	208/50 240/60	240/60	.13 .13	.08 .08	636 636	636 636	8.7 7.3	8.7 7.3	- -	- -	- -	- -	- -	- -
DA	12VDC	12VDC	.80 .80	.80 .80	15.1 15.1	15.1 15.1	9.5 9.5	9.5 9.5	- -	- -	- -	- -	- -	- -
DB	24VDC	24VDC	.39 .39	.39 .39	62 62	62 62	9.5 9.5	9.5 9.5	- -	- -	- -	- -	- -	- -

Connectors (Not polarity dependent)

DIN 43650 Industrial Form B	Maximum Cable Diameter: 9mm (0.35")		Strain Relief with Light		1/2" Conduit without Cord	Molded with 6' Cord	Strain Relief with Light & 6' Cord	
Type	Strain Relief without Cord	100-240 AC 48-120 DC	6-48 AC/DC	1/2" Conduit without Cord	Molded with 6' Cord	100-240 AC 48-120 DC	6-48 AC/DC	
Part Number	7020-001	7020-AA	7020-DB	7039-001	7020-006	7094-006	7094-007	

2/2 

3/2 

Pilot Inline Poppet Valves

Service Information

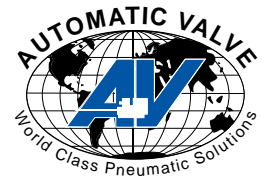

Valve must be disconnected from all air and electrical power sources before disassembly.

Service Kit Installation Instructions

1. Follow appropriate lock-out/tag-out procedures. Do not attempt to service a valve, if you are not familiar with lock-out/tag-out procedures.
2. Turn off electrical power to the valve.
3. Remove valve from all electrical and air power sources.
4. Ensure all stored air power is exhausted.
5. Remove operator cap by removing 4 socket head cap screws from the operator cap.
6. Remove internal screws concurrently, then remove existing serviceable components by "pushing" internal components gently out of the valve body.
7. Lubricate the designated + items in the assembly drawing at the right with a thin film of lubricant - the item should look "WET" with no excess lubricant visible.
8. Replace components as shown.
 - Use retention compound on each screw when reinstalling.
9. Orientate the operator cap by aligning pilot hole in body with pilot hole in cap.
10. Torque cap screws into body to 6,7 N-m (59 in-lbs) ±10%. Alternate tightening of screws, so cap "squeezes" evenly onto the body.

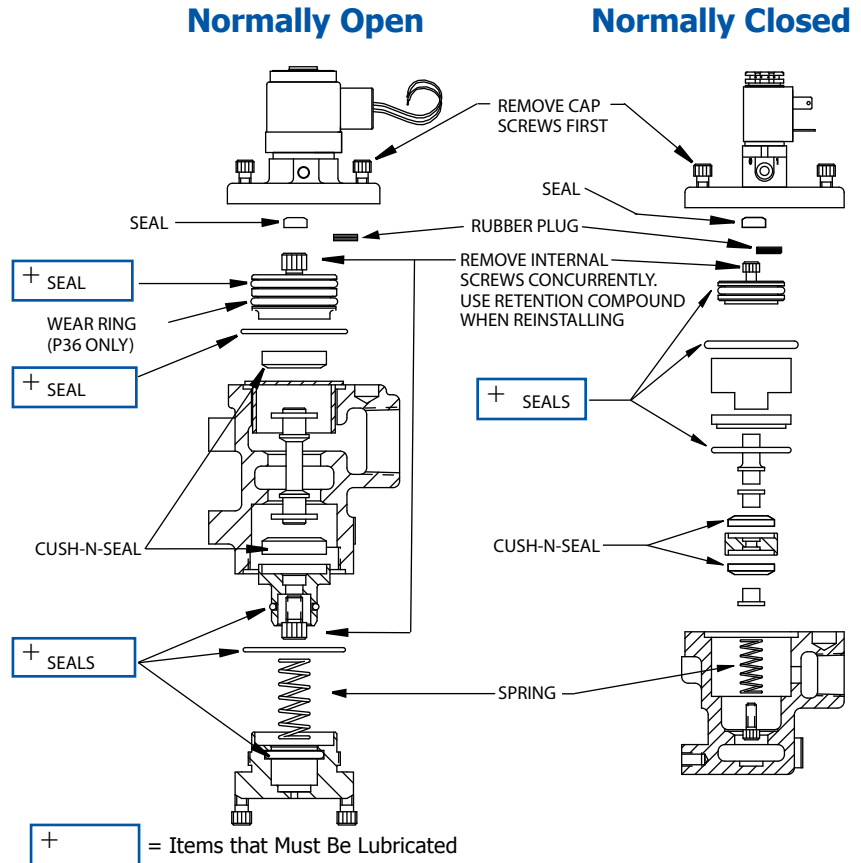

Air Line Lubrication of Automatic Valve products is not required, but is recommended to maximize service life. Oils should be compatible with seal material, have an ISO 32 or lighter viscosity, and have an aniline point between 82°C (180°F) and 99°C (210°F). Refer to the Maintenance Section of this catalog for recommended lubricants.

Model Numbers: Service Kits

Series	Description	Body Style			
		Normally Closed (NC)		Normally Open (NO)	
		Model Number	Contents	Model Number	Contents
P06	2 Way	K-P0600J	Rubber Plug (1), Seals (5), Cush-N-Seal (1), Spring (1)	K-P0600K	Rubber Plug (1), Seals (4), Cush-N-Seals (2), Spring (1)
	3 Way	K-P0600G	Rubber Plug (1), Seals (4), Cush-N-Seals (2), Spring (1)	K-P0600H	Rubber Plug (1), Seals (4), Cush-N-Seals (2), Spring (1)
P14	2 Way	K-P1400J	Rubber Plug (1), Seals (6), Cush-N-Seal (1), Spring (1)	K-P1400K	Rubber Plug (1), Seals (5), Poppet (1), Spring (1)
	3 Way	K-P1400G	Rubber Plug (1), Seals (4), Cush-N-Seals (2), Spring (1)	K-P1400H	Rubber Plug (1), Seals (4), Poppet (1), Spring (1)
P36	2 Way	K-P3600J	Wear Ring (1), Seals (5), Cush-N-Seals (2), Spring (1)	K-P3600K	Seals (5), Cush-N-Seals (2), Spring (1)
	3 Way	K-P3600G		K-P3600H	

AV **AUTOMATIC VALVE**

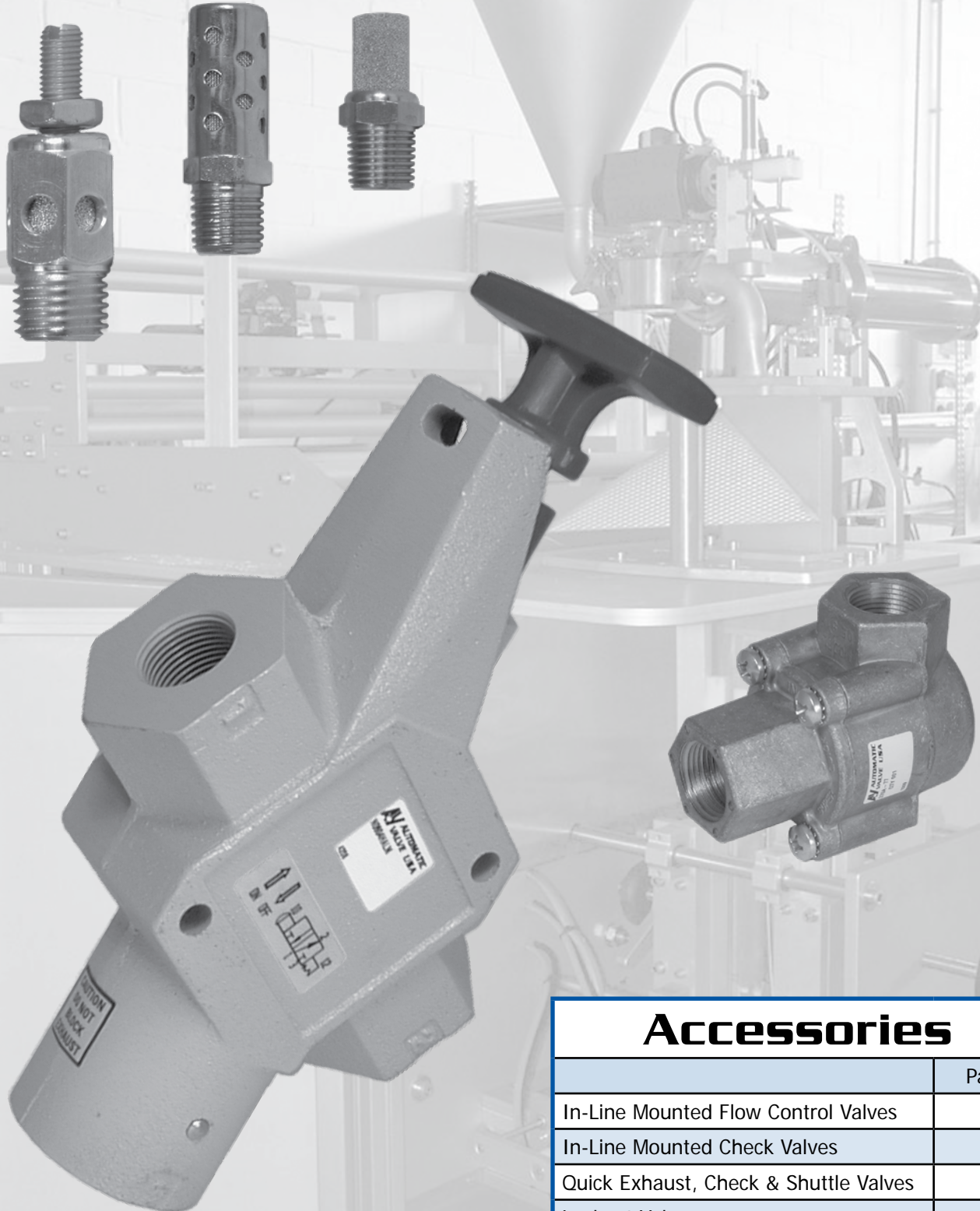

Accessories

	Page
In-Line Mounted Flow Control Valves	12
In-Line Mounted Check Valves	12
Quick Exhaust, Check & Shuttle Valves	13
Lockout Valves	14
Mufflers	15
Pneumatic Accessories	16-17



Accessories In-Line Mounted

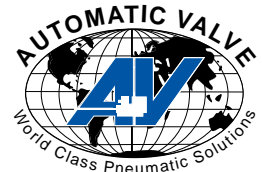

Flow Control Valves

- Allows free flow of air in one direction and adjustable flow in the opposite direction.
- Piped between valve and cylinder.
- High flow, accurate adjustment. Tamper proof locking screw standard.
- Self-cleansing poppet eliminates sediment accumulation.



200C-7

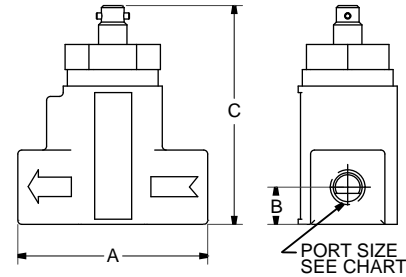
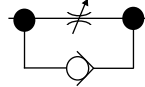

Model Numbers

Series	Model Number	Port Size	Flow l/min (Cv)	Weight Kg (lb)
MS2	200A-2	1/4	1614 (1.6)	0,23 (0.50)
	200A-3	3/8	1830(1.9)	
MS3	200A-35	1/2	2460 (2.5)	0,23 (0.50)
	200C-7	3/4	4820 (4.9)	
MS7	200C-71	1	4920 (5.0)	0,56 (1.25)
	200A-10	1	12990 (13.2)	
MS8	200A-12	1 1/4	14960 (15.2)	1,81 (4.0)
	200A-15	1 1/2	16730 (17.0)	

Dimensional Information

Dimensions mm (inches)		
A	B	C
73,2 (2.88)	14,2 (0.56)	85,6 (3.37)
73,2 (2.88)	14,2 (0.56)	85,6 (3.37)
102 (4.0)	44,5 (1.75)	135 (5.31)
140 (5.50)	39,6 (1.56)	208 (8.18)

Check Valves

- Allows low cracking pressure and full area free flow of air in one direction and instantaneous shut-off in the reverse direction.
- Self-cleansing poppet eliminates sediment accumulation.



203A-7

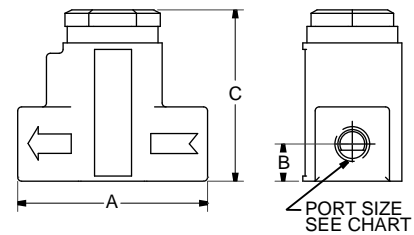
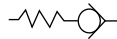

Model Numbers

Series	Model Number	Port Size	Flow l/min (Cv)	Weight Kg (lb)	Cracking Pressure BAR (PSIG)
MC3	203A-2	1/4	2340 (2.4)	0,23 (0.50)	0,02 (0.50)
	203A-3	3/8	2670 (2.7)		
	203A-35	1/2	3580 (3.6)		
MC7	203A-7	3/4	5210 (5.3)	0,56 (1.25)	0,46 (6.75)
	203A-71	1	5900 (6.0)		
MC8	203A-10	1	15550 (15.8)	1,63 (3.62)	0,21 (3.0)
	203A-12	1 1/4	17910 (18.2)		
	203A-15	1 1/2	18700 (19.0)		

Dimensional Information

Dimensions mm (inches)		
A	B	C
73,2 (2.88)	14,2 (0.56)	65,8 (2.59)
102 (4.0)	44,5 (1.75)	95,2 (3.75)
140 (5.50)	39,6 (1.56)	142 (5.56)

One model does all three functions

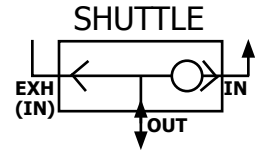
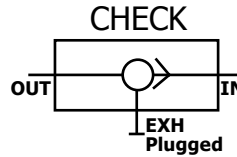
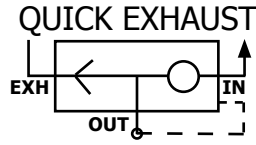

Features

- Rugged internal construction outlasts and out performs the competition.
- Quick Exhaust: When **IN** is pressurized, flow is from **IN** to **OUT** with **EXH** blocked. When **OUT** is pressurized, flow is from **OUT** to **EXH** with **IN** blocked
- Check Valve: Free flow from **IN** to **OUT** with **EXH** plugged. No flow from **OUT** to **IN** with **EXH** plugged.
- Shuttle Valve: When **IN** is pressurized, flow is from **IN** to **OUT** with **EXH** blocked. When **EXH** is pressurized, flow is from **EXH** to **OUT** with **IN** blocked.

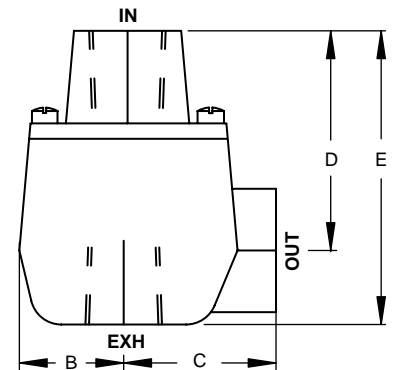
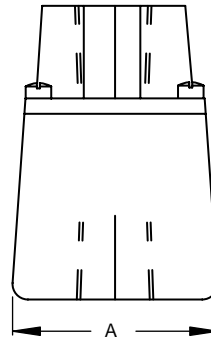

Model Numbers

Series	Model Number	Port Size NPTF		Flow l/min (Cv)	Pressure BAR (PSIG)		Weight Kg (lb)
		IN, OUT	EXH		Min	Max	
MQ2	370A-21	1/8	1/4	790 (0.72)	0,3 (4)	10.7 (150)	.08 (.17)
	370A-22	1/4	1/4	890 (0.97)			.07 (.16)
MQ3	370A-32	1/4	3/8	1870 (1.44)	0,2 (3)	10.7 (150)	.15 (.31)
	370A-33	3/8	3/8	2160 (1.48)	0,1 (2)		.29 (.63)
MQ7	370A-75	1/2	3/4	2560 (2.9)	0,1 (1)	10.7 (150)	.45 (.99)
	370A-77	3/4	3/4	2850 (4.1)			.41 (.90)

Dimensional Information

Dimensions mm (inches)				
A	B	C	D	E
27,7 1.09	13,9 0.55	20,5 0.81	30,9 1.22	42,4 1.67
38,1 1.5	21,1 0.83	31,8 1.25	45,2 1.78	60,4 2.38
55,4 2.18	28,9 1.14	45,9 1.81	70,6 2.78	92,9 3.66



Accessories Lockout Valves

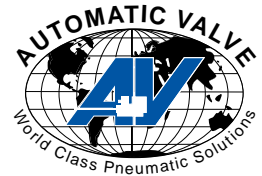

N1606HALM

Soft Start Option

- To order a Lockout Valve with Soft Start, add -SS to the end of the model number.

Features

- 3 way, 2 position valve.
- Short stroke for quick response.
- Padlockable in the closed position.
- Bright red handle for visibility.
- When handle is pulled outward, Inlet Port 1 is connected to Outlet Port 2 and Exhaust Port 3 is blocked.
- When handle is pushed inward, Inlet Port 1 is blocked and Outlet Port 2 is connected to Exhaust Port 3.
- These products are defined as energy isolation devices, NOT AN EMERGENCY STOP DEVICE.

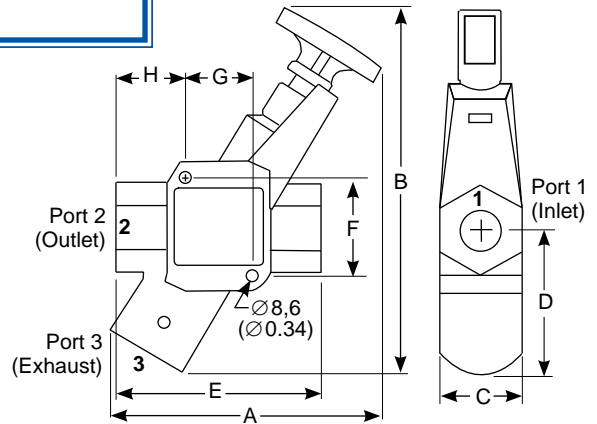

Model Numbers

Series	3/2 NO 	Port Size		Flow l/min (Cv)	Material		Wt. Kg (lb)		
		1,2	3		Body	Seal			
N06	N0604HALM	3/8	3/4	4630 (4.7)	Aluminum	NBR	0,7 (1.5)		
	N0605HALM	1/2		6994 (7.1)					
	N0606HALM	3/4		8170 (8.3)					
N16	N1606HALM	3/4	1 1/4	12904 (13.1)			Aluminum	NBR	1,5 (3.3)
	N1607HALM	1		16351 (16.6)					
	N1608HALM	1 1/4		19011 (19.3)					

Dimensional Info

Dimensions mm (in)							
A	B	C	D	E	F	G	H
163 (6.4)	224 (8.8)	51 (2.0)	76.2 (3.0)	111 (4.4)	57,2 (2.3)	31,8 (1.3)	41,4 (1.6)
196 (7.7)	274 (10.8)	58 (2.3)	95,3 (3.8)	140 (5.5)	69,9 (2.8)	44,4 (1.8)	47,8 (1.9)

* To add Soft Start feature, add -SS to end of Part Number

Model Numbers & Dimensional Information

Exhaust Mufflers							
Series	Description	Part Number	Pipe Size NPT	Flow l/min (C _v)	Length mm(in)	Hex Size mm (in)	Wt kg (lb)
84C	 <ul style="list-style-type: none"> Reduces exhaust noise level in air systems. Maintains full volume air flow with minimum back pressure. Threads into exhaust port. 	84C-1	1/8	1160 (1.3)	34,9 (1.38)	11,1 (7/16)	0,05 (0.10)
		84C-2	1/4	2060 (2.3)	44,5 (1.75)	14,3 (9/16)	0,05 (0.10)
		84C-3	3/8	4380 (4.9)	57,3 (2.25)	17,5 (11/16)	0,09 (0.20)
		84C-5	1/2	6080 (6.8)	69,0 (2.72)	22,2 (7/8)	0,11 (0.25)
		84C-7	3/4	15520 (14.0)	80,3 (3.16)	17,5 (11/16)	0,19 (0.41)
		84C-10	1	16090 (18.0)	98,4 (3.88)	20,6 (13/16)	0,39 (0.88)
		84C-12	1 1/4	21100 (23.6)	114 (4.50)	42,9 (1 11/16)	0,59 (1.31)
		84C-15	1 1/2	34870 (39.0)	127 (5.0)	50,8 (2.0)	0,77 (1.68)

Sintered Exhaust Mufflers							
Series	Description	Part Number	Pipe Size NPT	Flow l/min (C _v)	Length mm(in)	Hex Size mm (in)	Wt kg (lb)
84D	 <ul style="list-style-type: none"> Reduces exhaust noise level in air systems. Sintered bronze bonded to a copper plated male pipe fitting. Corrosion resistant. Cleanable 40 micron filter element. 	A7007-010	10-32	150 (0.2)	8,6 (0.34)	6,3 (1/4)	-
		84D-1	1/8	310 (0.4)	28,6 (1.12)	11,1 (7/16)	0,01 (0.01)
		84D-2	1/4	600 (0.7)	34,9 (1.37)	14,3 (9/16)	0,02 (0.04)
		84D-3	3/8	660 (0.8)	38,1 (1.50)	17,5 (11/16)	0,03 (0.06)
		84D-5	1/2	1600 (1.9)	47,6 (1.88)	22,2 (7/8)	0,05 (0.10)
		84D-7	3/4	3170 (3.7)	57,2 (2.25)	27,0 (1 1/16)	0,07 (0.16)
		84D-10	1	4360 (4.9)	73,0 (2.88)	33,3 (1 5/16)	0,13 (0.28)

Exhaust Restrictor/Sintered Mufflers							
Series	Description	Part Number	Pipe Size NPT	Flow l/min (C _v)	Length mm(in)	Hex Size mm (in)	Wt kg (lb)
266B	 <ul style="list-style-type: none"> Reduces exhaust noise level in air systems. Allows adjustment of exhaust air flow to accurately control cylinder speeds. Corrosion resistant. Cleanable 40 micron filter element. 	266B-1	1/8	1070 (1.2)	37,3 (1.47)	11,1 (7/16)	0,01 (0.03)
		266B-2	1/4	1160 (1.3)	55,9 (2.20)	14,3 (9/16)	0,02 (0.05)
		266B-3	3/8	1790 (2.0)	63,0 (2.48)	17,5 (11/16)	0,04 (0.09)
		266B-5	1/2	3310 (3.7)	85,1 (3.35)	22,2 (7/8)	0,07 (0.16)
		266B-7	3/4	5270 (5.9)	96,5 (3.68)	27,0 (1 1/16)	0,12 (0.27)
		266B-10	1	6080 (6.8)	126,2 (4.97)	33,3 (1 5/16)	0,22 (0.48)



Accessories Pneumatic

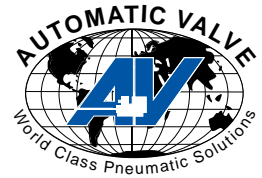

Features

- Media: Compressed air or inert gas, lubricated or non-lubricated.
- Seals: NBR
- Springs and Bodies: Stainless Steel.
- Internals: Brass and zinc plated brass.
- Plastic Parts: PA.
- Pressure Range: 100 kPa - 1035 kPa (15 psi - 150 psi), (1 BAR - 10 BAR).
Note: Soft Start = 310 kPa - 1035 kPa (45 psi - 150 psi), (3 BAR - 10 BAR).
- Temperature Range: -7°C to 65°C (20°F - 150°F)

Right Angle Flow (RAF) Control

- Eliminates at least one fitting.
- Efficient control of air at source.
- Locks in place once cylinder speed is set.
- Flow from Port 2 to Port 1
- Metered-In or Metered-Out

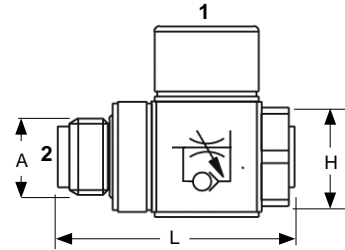

Model Number	SCFM	Port Size	Dimensions mm (inches)		
			A	H	L
A7209-100	12.02	1/4 NPT	1/4	41 (1.62)	19 (0.75)
A7209-101	34.52	3/8 NPT	3/8	47 (1.85)	23 (0.91)
A7209-102	12.02	1/4 BSPP	1/4	41 (1.62)	19 (.75)
A7209-103	34.52	3/8 O.D. Tube Fitting	3/8	47 (1.85)	23 (0.91)

Port Mounted Regulator (PMR)

- Return flow equals regulated flow, self-relieving.
- Incorporates by-pass check.
- Proven payback with point of use air reductions.
- Operating Pressure Primary: 1-16 BAR (15-235 PSIG)
- Flow from Port 1 to Port 2

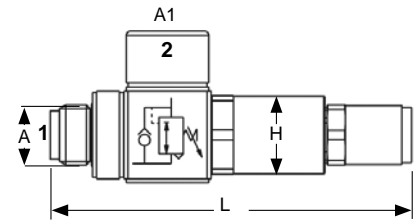
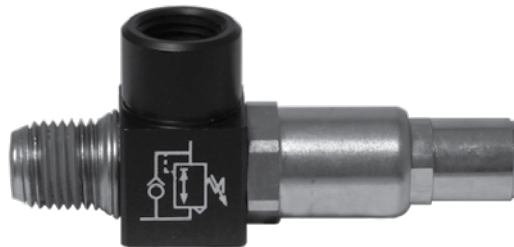

Model Number	Port Size		Dimensions mm (inches)	
	A	A1	H	L
A7209-110	1/4 NPT	1/4 NPT	17 (0.69)	81 (3.18)
A7209-111	3/8 NPT	3/8 NPT	22 (0.86)	88 (3.46)
A7209-112	1/4 BSPP	1/4 BSPP	17 (0.69)	81 (3.18)
A7209-113	3/8 O.D. Tube Fitting	3/8 NPT	22 (0.86)	88 (3.46)

Pilot Operated Check (POC) Valve

- Stops flow on loss of air.
- Eliminates at least one fitting.
- 1/8" Available By Special Order
- Operating Pressure: 1-10 BAR (15 - 150 PSIG)

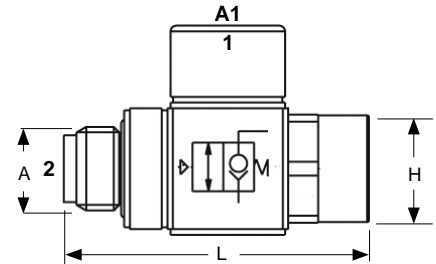

Model Number	SCFM		Port Sizes		Dimensions mm (in)	
	Port 1 to 2 at 90 psi	Port 2 to 1 at 0 psi	A	A1	H	L
A7209-120	21.78	23.89	1/4 NPT	1/4 NPT	17 (0.69)	48 (1.87)
A7209-121	41.25	40.81	3/8 NPT	3/8 NPT	22 (0.86)	55 (2.16)
A7209-122	21.78	23.89	1/4 BSPP	1/4 BSPP	17 (0.69)	48 (1.87)
A7209-123	41.25	40.81	3/8 O.D. Tube Fitting	3/8 NPT	22 (0.86)	55 (2.16)

Soft Start

- Delays full flow based on number of turns of set screw.
- Prevents cylinders/loads from rapid extension at start up
- Operating Pressure: 3-10 BAR (45 - 150 PSIG).

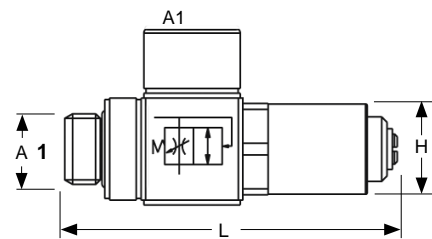
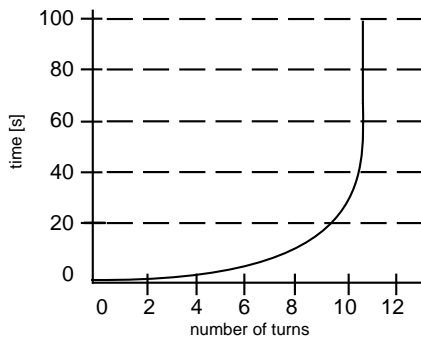

Model Number	SCFM	Port Sizes		Dimensions	
		A	A1	mm H (inches)	mm L (inches)
A7209-120	36.7	1/4 NPT	1/4 NPT	17 (0.69)	63 (2.48)
A7209-121	61.8	3/8 NPT	3/8 NPT	22 (0.86)	69 (2.72)
A7209-122	36.7	1/4 BSPP	1/4 BSPP	17 (0.69)	63 (2.48)
A7209-123	61.8	3/8 O.D. Tube Fitting	3/8 NPT	22 (0.86)	69 (2.72)

AV AUTOMATIC VALVE

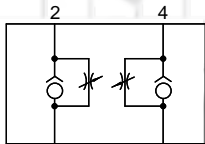
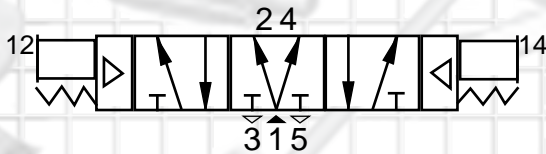

$$C_v = \frac{Q}{22.67} \times \sqrt{\frac{2 \times G \times T}{(P_1^2 - P_2^2)}}$$

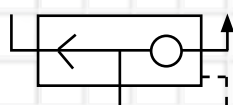
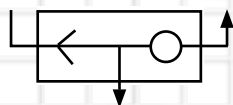
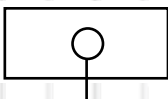

Precautions, Engineering & Maintenance

	Page
Symbols	J2
DESIGN:	
Precautions	J3
Valve Sizing Calculations	J4
Valve Sizing Chart	J5
Valve Conversion Chart	J5
Flow Characteristics	J6
INSTALLATION:	
Precautions	J7
Operating Media	J7
Air Lines	J7
Pipe and Fitting Preparation	J7
Mounting	J8
Valve Inlet Line	J8
Valve Outlet Lines	J8
Valve Exhaust Ports	J8
Filtration	J9
Operating Pressures and Temperatures	J9
Pilot Pressure	J9
Lubrication	J9
MAINTENANCE:	
Precautions	J10
Preventative Maintenance	J10
Servicing	J10
TROUBLESHOOTING:	
Precautions	J11
Troubleshooting Guide	J11
Troubleshooting Solutions	J12-J17
Glossary	J18



Precautions, Engineering and Maintenance Symbols

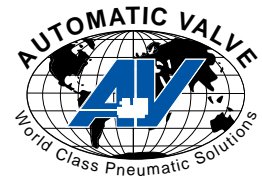

Valves	
2/2 Two Way Valves	
Normally Closed	Normally Open
3/2 Three Way Valves	
Normally Closed	Normally Open
4/2 Four Way Valves - 4 Ports	
5/2 Four Way Valves - 5 Ports	
3/3 Three Way Valves 3 Positions	
5/3 Four Way Valves 3 Positions	
Closed Center	
Exhaust Center - Inlet Blocked	
Pressure Center - Exhaust Blocked	
Valve Operators	
Spring	Manual
Push Button	Lever
Pedal or Treadle	Mechanical

Valve Operators	
Detents	
(1) Position	(2) Position
(3) Position	
Solenoid	
Pilot Pressure Remote Supply	
Pilot Pressure Internal Supply	
Solenoid and Pilot	
Internal Pilot	Remote Pilot
Composite Valve Operators	
Basic: One Operator Operates Valve	
Either Signal Operates Valve	
Solenoid & Pilot or Manual Override & Pilot Operate Valve	
Accessories	
Flow Control Valve Adjustable	Check Valve
Exhaust Restrictor	Shuttle Valve
Muffler	

Cylinders	
	Single Acting
	Double Acting
	Double Rod End
Conductor	
	Working Line
	Pilot Line
	Exhaust Line
Miscellaneous	
	Lines Crossing
	Lines Joining
	Direction of Air Flow
	Filter Separator Manual Drain
	Filter Separator Automatic Drain
	Lubricator
	Airline Pressure Reg. Adjustable, Relieving
	Filter, Regulator and Lubricator
	Pressure Gage
	Fixed Displacement Compressor
	Variable Displacement Compressor
	Pressure Switch



Precautions, Engineering and Maintenance Design



Precautions

Automatic Valve products are general purpose industrial pneumatic and vacuum devices. They are not themselves inherently harmful. However, the control systems in which they operate must have necessary safeguards to prevent injury or damage should failure of system components occur.

Use Automatic Valve products only within the operating specifications stated for the product in each catalog section or on the drawings.

Read and be familiar with the precautions listed under the 'Design', "Installation", "Maintenance" and "Troubleshooting" portions of this section of the catalog or D7179-004. Provide adequate warnings and information on system components and in system operating manuals.

Power Presses: Do not use Automatic Valve Corp's valves for power presses. Automatic Valve does not manufacture the special purpose dual safety clutch and brake valves required by OSHA Regulation 1910.217, dated November 1, 1975, and ANSI Standard B11.1, Revision 1982, and EN 13736: 1999.

Two Position Valves: Two position 2 and 3 way valves will have a flow path from the valve's inlet port to one of the valve's outlet ports in either one or both of the two positions. 4 way valves will always have a flow path from the inlet to one of the outlet ports regardless of its position. If retaining pressurized air in the system presents a hazard during system operation or servicing, a separate method must be used to exhaust the trapped air.

Three Position Valves: Solenoid operated and air piloted three position 3 way and 4 way valves will move to the center position if one of the operators is not actuated. Manually operated three position valves may or may not return to the center position, depending on the centering operator. When one of the operators is actuated, a flow path will exist as it does in two position valves. When the valve is in the center position, the flow path described below exists.

Block Center: All ports, including inlet and exhaust ports, are blocked when the valve is in the center position. If trapping air in either or both of the valve outlet cylinder ports presents a hazard during system operation or servicing, a separate method must be used to exhaust the trapped air or the valve should not be used.

Caution: *Valves with blocked centers should be used with discretion because there is no makeup air. Any leaks in the valve, cylinder, or system lines and fittings can cause drifting (movement) of the cylinder.*

Exhaust Center: When the valve is in the center position, the inlet port is closed and the cylinder ports are open to exhaust ports. If this condition is hazardous in either operation or during servicing, the valve should not be used.

Pressure Center: When the valve is in the center position, the inlet port pressurizes the cylinder ports and the exhaust ports are blocked. If this condition is hazardous in either operation or during servicing, the valve should not be used.

Solenoid Manual Overrides: Some Automatic Valve air piloted and solenoid operated valves incorporate manual overrides which, when actuated, shift the valve as if the solenoid or air pilot were actuated. If accidental or intentional operation of the manual override could cause a dangerous problem, the valve should be ordered without a manual override.

Valve Sizing Chart

The chart below may be used instead of mathematical calculations for close approximations or required valve Cv. The Valve Sizing Chart assumes the following:

- Valve inlet pressure is 80 PSIG.
- Pressure drop through the valve is 10% inlet pressure or 8 PSI.
- There are no line restrictions between the valve and cylinder.
- Distance between the valve and cylinder is 6 feet or less.

Step 1: Calculate the required cylinder speed in inches per second: $S = \frac{L}{t}$

Where: **S** = Cylinder speed in inches per second
L = Length of cylinder stroke in inches
t = Time to extend or retract in seconds

Step 2: Choose the applicable cylinder bore size column.

Step 3: Move vertically down the column to select a speed (inches per second) equal to or greater than the calculated speed and read the required Cv in the left hand column.

Cylinder Bore Size (inches):		Speed														
		0.75	1.00	1.13	1.50	2.00	2.50	3.00	3.25	4.00	5.00	6.00	7.00	8.00	10.00	12.00
Cv	0.1	26.8	15.1	11.9	6.7	3.8	2.4	1.7	1.4	0.9	0.6	0.4	0.3	0.2	0.2	0.1
	0.2	53.7	30.2	23.9	13.4	7.5	4.8	3.4	2.9	1.9	1.2	0.8	0.6	0.5	0.3	0.2
	0.5	134	75.5	59.6	33.6	18.9	12.1	8.4	7.1	4.7	3.0	2.1	1.5	1.2	0.8	0.5
	1.0	268	151	119	67.1	37.7	24.2	16.8	14.3	9.4	6.0	4.2	3.1	2.4	1.5	1.0
	2.0	537	302	239	134	75.5	48.3	33.6	28.6	18.9	12.1	8.4	6.2	4.7	3.0	2.1
	4.0		604	477	268	151	96.6	67.1	57.2	37.7	24.2	16.8	12.3	9.4	6.0	4.2
	8.0				536	302	193	134	114	75.5	48.3	33.6	24.7	18.9	12.1	8.4
	16.0					604	387	268	229	151	96.6	67.1	49.3	37.7	24.2	16.8
	32.0						773	537	457	302	193	134	98.6	75.5	48.3	33.6

Valve Conversion Chart

FOR:
 Single operator spring return valves with balanced spools

PORTS:
 1 = Supply = P
 2 = Outlet = A
 3 = Exhaust = EA
 4 = Outlet = B
 5 = Exhaust = EB

Operation	Plug	Supply*	Outlet	Exhaust
2 Way Normally Closed	2, 3, 5	1	4	-
2 Way Normally Open	4, 3, 5	1	2	-
3 Way Normally Closed	2, 3	1	4	5
3 Way Normally Open	4, 5	1	2	3
3 Way Diverter	3, 5	1	2, 4	-
3 Way Selector	3,5	2, 4	1	-
4 Way	-	1	2, 4	3, 5

*Minimum operating pressure is 35 psi. Use an external pilot when using a port other than Port 1 for supply or when using a fluid media besides air.



Precautions, Engineering and Maintenance

Design

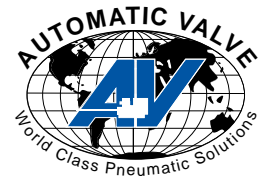

Flow Characteristics

The chart at the right shows the flow (scfm) characteristics for a valve with a C_v of 1.0. Because there is a linear relationship between C_v and flow, a valve with a C_v of 3.0 will have three times the flow at the same pressure drop as does a valve with a C_v of 1.0. This linear relationship may be used to find the required C_v for any flow rate and pressure drop.

Example: Required - Flow of 200 scfm at 80 psig inlet with a 4 psi pressure drop.

Step 1: From the chart at right, a valve with a C_v of 1.0 and a pressure drop of 4 psi, has a flow of 20 scfm.

Step 2: Divide the required flow, 200 scfm, by 20 scfm to determine the required C_v :

$$\frac{200 \text{ scfm}}{20 \text{ scfm}} = \mathbf{10 C_v}$$

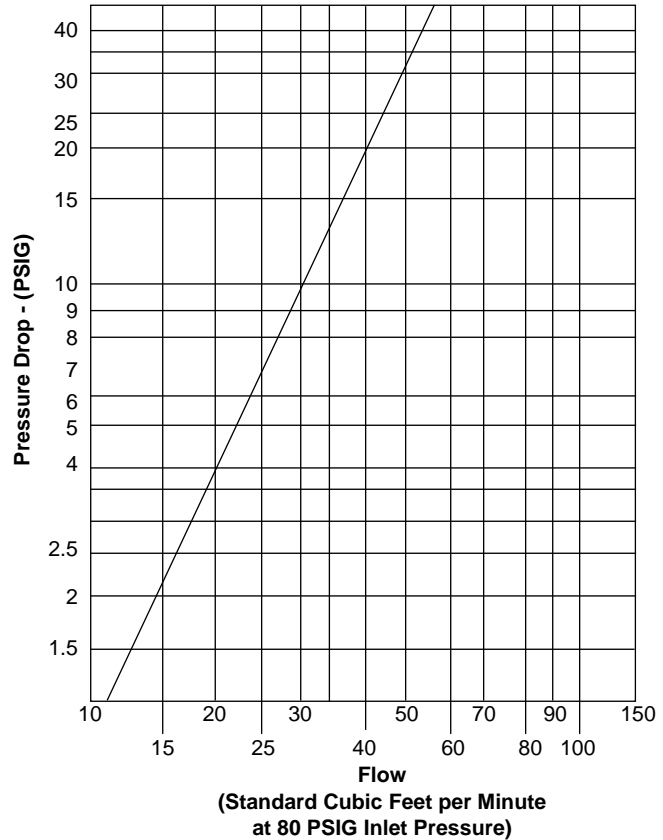

The "SCFM to C_v Approximation" chart at the right is another method for determining C_v . This chart assumes conditions of 70°F with a 10% pressure drop. "Q" is the standard cubic feet of free air (scfm).

Example: Required - Flow of 200 scfm at 80 psig inlet with a 10% pressure drop and 70°F.

Step 1: From the chart at right, the formula for 80 inlet psig is:

$$C_v = 0.0376 \times Q$$

Where: Q = 200 scfm

Step 2: $C_v = 0.0376 \times 200 = 7.52$

An approximation of the C_v with a required flow of 200 scfm at 80 psig inlet with a 10% pressure drop could be obtained from the graph above by determining the numerical value of the 10% pressure drop (80 psig \times .10) = 8 psig. This 8 psig pressure drop has a flow of about 26.5 scfm. 200 scfm divided by 26.5 = **7.47 C_v** .

SCFM to C_v Approximation @ 70° with a 10% Pressure Drop

Inlet Pressure psig	C_v
30	0.0890 x Q
40	0.0700 x Q
50	0.0575 x Q
60	0.0489 x Q
70	0.0425 x Q
80	0.0376 x Q
90	0.0338 x Q
100	0.0306 x Q
110	0.0280 x Q
120	0.0258 x Q

Precautions

Automatic Valve products should only be installed by trained and qualified personnel who have knowledge of how specific pneumatic products are to be piped and electrically connected.

Install Automatic Valve products only in systems which contain adequate safeguards to prevent injury or damage in the event of product failure.

Insure that the system has provisions for turning air and electrical power off and for exhausting all air trapped within the system.

Operating Media

Automatic Valve products are designed primarily for use with air or other inert gases. For use with other media, contact your Automatic Valve distributor.

When solenoid piloted valves are used for vacuum service, an external pilot supply must be used.

Air Lines

Before installing any pneumatic product, air lines should be blown clean to remove all contamination. Clean air line filters after purging is completed.

Caution: Compressed air streams are dangerous. Divert the stream away from personnel and equipment. Personnel in the area must wear suitable eye and ear protection.

Pipe and Fitting Preparation

Automatic Valve recommends the use of pipe sealant instead of Teflon tape when making connections to NPT ports. The sealant used by Automatic Valve is specified in the bill of material on the drawing.

Pipe sealant should be applied behind the first two or three threads to prevent the sealant from entering and contaminating the system.

APPLY PIPE SEALANT LEAVING
THE LAST 2 TO 3 THREADS
FREE OF SEALANT

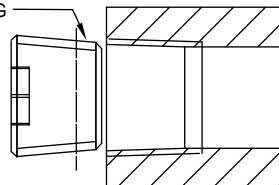

While no torque values are available for NPT fittings, a general rule of thumb is to install the fitting hand tight and then turn an additional 1 to 1 ½ turns.



Precautions, Engineering and Maintenance Installation



Mounting

Spool valves must be mounted with the spool in a horizontal position. Other valves, cylinders, and accessories may be mounted in any position.

Refer to dimensional data in the catalog or on the drawing.

Where practical, mount valves so that they are accessible for service and so that solenoid manual overrides can be used if applicable.

Valve Inlet Lines

Valve inlet lines should have an inside diameter equal to or greater than the valves' inlet port size as shown in the following chart:

Inlet Tap Size	Supply ID (min.)	Inlet Tap Size	Supply ID (min.)
1/8 NPT	0.25"	3/4 NPT	0.75"
1/4 NPT	0.38"	1 NPT	1.00"
3/8 NPT	0.50"	1 1/4 NPT	1.25"
1/2 NPT	0.63"	1 1/2 NPT	1.50"

Restricted inlet lines will reduce the system operating speed and can cause valve malfunction. Eliminate or minimize sharp bends and install regulators as close as possible to the valve inlet port.

Valve Outlet Lines

For optimum system performance, locate valves as close as possible to the device they are operating. Minimize all sharp bends and other restrictions.

Valve Exhaust Ports

Spool valve exhaust ports may be restricted to provide speed control for cylinders or other devices.

Poppet valve exhaust ports must not be restricted. Such restriction can cause valve malfunction.

All open valve exhaust ports should have mufflers installed to reduce noise levels and to prevent the entry of atmospheric contamination or directed downward with elbows to prevent the entry of atmospheric contamination.



Precautions, Engineering and Maintenance Installation



Filtration

Filters with 50 micron elements are adequate for all Automatic Valve products. However, where devices not made by Automatic Valve are used in the system, the manufacturer should be consulted regarding their filtration requirements.

Install filters within 20 feet of the valve or per the manufacturer's instructions.

Operating Pressures and Temperatures

Minimum and maximum operating pressures and temperatures for Automatic Valve products are specified in each catalog section or notes 5 - 8 on the drawing. While products may function at lower or higher limits, such operation is unsafe and must be avoided.

Contact your Automatic Valve distributor if your application requires products that exceed the operating limits shown.

Pilot Pressure

For proper operation, pilot pressure must be within the minimum and maximum operating pressures shown in each catalog section or notes 5 - 8 on the drawing.

If solenoid piloted valves are to operate at lower or higher operating pressures than the specified pilot pressure limits, an external pilot supply within the proper pressure range must be used. Valves may either be ordered with an external pilot supply, option "B", or may be field converted as shown in each catalog section or on the drawing.

Lubrication

Automatic Valve products are pre-lubed at the factory. Components that are pre-lubed are noted with a '+' in each catalog section or in the bill of material on the drawing.

Lubrication of Automatic Valve products is not required but is recommended to maximize service life. Where devices not made by Automatic Valve are used in the system, the manufacturer should be consulted regarding their lubrication requirements.

Lubricators should be installed downstream of regulators, per the manufacturer's instructions.

Oils used in air line lubricators should be compatible with seals used in the system. Generally, Automatic Valve products use Buna "N" seals. Fluoroelastomer seals are available as option "A". Oils should be paraffinic, petroleum based with oxidation inhibitors, an ISO 32 or lighter viscosity, and an aniline point between 82°C (180°F) and 99°C (210°F).

In general, lubricators should not be synthetic or reconstituted, and should not have alcohol content or detergent additives.



Precautions, Engineering and Maintenance Maintenance



Precautions

Automatic Valve products should be serviced only by qualified and knowledgeable personnel who understand the function and operation of the product.

Before servicing any pneumatic system, verify that the air and electrical power are off and that all air within the system has been exhausted.

Take all necessary precautions to prevent degradation of products caused by stepping on them, dropping them or hitting them with a hammer or other object.

Return products that are damaged as a result of improper handling to Automatic Valve for inspection.

Preventative Maintenance

Install all pneumatic systems as described in the Installation section. Improper installation can cause sluggish system performance and, if contaminants are not purged, premature wear of components.

Drain, clean, and service air line filters on a periodic basis or as recommended by the manufacturer.

Adjust air line lubricators per the manufacturer's recommendations (generally, one drop per minute) and fill the reservoir at scheduled intervals. When filling the reservoir, use lubricating oils as prescribed under "Installation".

To avoid possible solenoid malfunction, keep all electrical switches and relay contacts in good condition.

Inspect mechanical actuators, such as cams and rollers, for signs of wear and replace when necessary.

Automatic Valve products are designed to operate in normal air system environments with a minimum of maintenance. In extreme conditions, as evidenced by sluggish performance or sticking problems, a periodic program for cleaning internal product components should be established.

To clean products, use a water soluble detergent. To avoid component damage, do not use abrasive compounds or scrape metal parts.

Servicing

When servicing Automatic Valve products, use only those components furnished in Automatic Valve service kits. Items contained in these kits are designated in the service portion of each catalog section or on the drawing.

After a product has been disassembled, discard all items designated as service kit items.

Clean remaining metallic components, except for solenoid coils and housings, with a non-abrasive, water soluble detergent.

When reassembling the product, refer to the appropriate service section or the drawing and lightly lubricate the designated items as per the drawing instructions.

Test the product according to the drawing instructions.

Precautions

Read and follow the precautions listed in the "Maintenance" section of this catalog. Stay clear of all moving parts that must be actuated when troubleshooting.

Troubleshooting Guide

Of all the components in an electrical/mechanical/pneumatic system, it is most often the control valve that will be faulted for system malfunction. In many cases, the valve is only the symptom of the problem. Leaking cylinder seals, poor electrical connectors, clogged air line filters, and broken or jammed mechanical components are just a few of the problems that can initially be diagnosed as a valve problem. Before disassembling any system component, use the troubleshooting guide to try to pinpoint the exact cause of the problem. The Solutions referenced in the last column are found on the following pages.

	Problem	Possible Cause	Solution
1	Valve Leaks to Exhaust when Not Actuated	Defective cylinder or valve seals	1
		Maintenance	17
2	Valve Leaks to Exhaust when Actuated	Defective cylinder or valve seals	1
		Inadequate air or pilot supply	2 & 3
		Voltage Leak	see Problem 8
		Contamination	4 & 5
		Maintenance	17
3	Solenoid Pilot Leaks	Dirt on seals or seal wear	6
		Maintenance	17
4	Operator Vent Leaks	Worn or damaged seal	7
		Maintenance	17
5	Sluggish Operation	Contamination	4 & 5
		Inadequate air or pilot supply	2 & 3
		Improper or clogged muffler	8
		Inadequate or improper lubrication	9
		Mechanical binding	15
		Maintenance	17
6	Poppet Valve Chatter	Inadequate air or pilot supply	2 & 3
		Contamination	4 & 5
		Improper or clogged muffler	8
		Inadequate or improper lubrication	9
		Maintenance	17
7	Solenoid Buzzes or Solenoid Burnout	Incorrect voltage	10
		Faulty or dirty solenoid	11
		Maintenance	17
8	Solenoid Valve Fails to Shift Electronically, but Shifts with Manual Override	Incorrect voltage	10
		Override left activated	12
		Defective coil or wiring	13
		Maintenance	17
9	Solenoid Valve Fails to Shift Electronically or with Manual Override	Inadequate air or pilot supply	2 & 3
		Contamination	4 & 5
		Inadequate or improper lubrication	9
		Mechanical binding	15
		Maintenance	17
10	Valve Shifts but Fails to Return	Broken spring	14
		Mechanical binding	15
		Maintenance	17
11	Cam Operated Valve Fails to Operate	Cam or roller adjustment	16
		Maintenance	17



Precautions, Engineering and Maintenance Troubleshooting



Solutions for:

1. Valve Exhaust Port Leakage

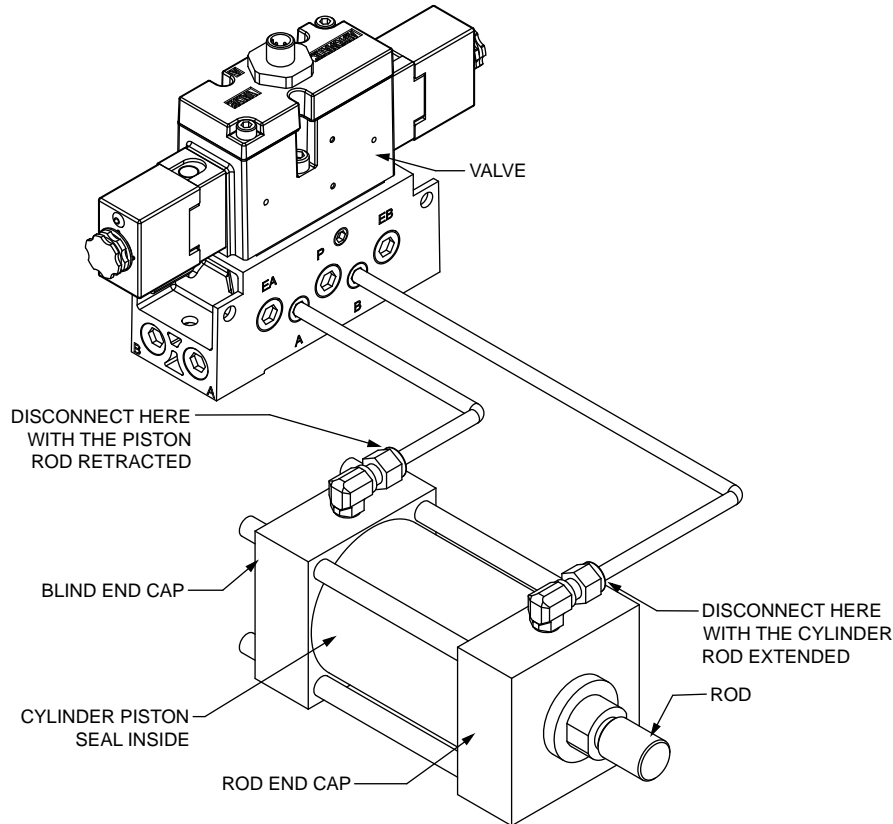

Verify if the leakage is caused by the cylinder or valve as follows: (Use extreme caution, as the valve and cylinder will both be actuated during this procedure.)

1. With the piston rod retracted, disconnect the line at the cylinder blind end cap. If air comes out of the cylinder port fitting, as shown above, the cylinder piston seals are defective and must be replaced. If there is no leakage, reconnect the line.
2. With the cylinder rod extended, disconnect the line at the cylinder rod end cap. If there is leakage at the cylinder port fitting, the cylinder piston seals must be replaced.
3. If there is no leakage at the fitting, the leakage is caused by defective valve seals or gaskets. Reconnect the line and install new seals and gaskets available in the valve body service kit.

2. Inadequate Air Supply

An inadequate air supply can cause the pilot supply pressure to drop during valve actuation. This can result in valve chatter or oscillation, particularly in poppet valves, or may keep the valve in a partially shifted condition where it continually blows to exhaust. If the pressure gage falls by more than 10% during valve actuation, there is probably a deficiency in the air supply system.

1. Airline filters should be cleaned and pressure regulators checked for proper operation. The line sizing recommendations in the Installation section should be reviewed and modifications made if restrictions or undersize inlet lines are found.
2. Verify that the air compressor has sufficient capacity to meet all systems requirements.

Solutions for (continued):

3. Pilot Supply

Remote air pilot signals or pilot supplies to externally piloted solenoid valves that are restricted or are below the minimum operating pressures can cause valve oscillation or partial actuation resulting in exhaust port leakage.

1. Verify that the operating signal is at the proper pressure and that there are no restrictions caused by clogged filter elements or improperly sized pilot lines.
2. Refer to #2. Inadequate Air Supply for additional troubleshooting suggestions.

4. Liquid Contamination

Accumulation of oil and water at low points in the system, including valves, can cause erratic or sluggish performance and exhaust leaks.

1. If heavy concentrations of water or oil are found when a device is disassembled, it should be thoroughly cleaned, re-lubricated and reassembled.
2. Filters and lubricators should be cleaned and checked for proper operation. If necessary, air lines should be rerouted to eliminate low points.
3. If there are concentrations of moisture at below freezing temperatures, ice can form and cause erratic operations, or completely bind system components. In such situations, steps must be taken to dry the air to a dew point of at least 12°C (10°F) below the minimum system operating temperature. Also, filters should be equipped with automatic drains.

5. Solid Contaminants

Solid contaminants, such as broken pieces of pipe threads, pipe sealant or tape, or rust scale, can cause valve seal damage, scratches on spools and sealing surfaces, or system binding and possible exhaust leaks. Such problems are most often encountered in new installations that have not been properly purged or where there are heavy concentrations of atmospheric contaminants.

1. In many cases, cycling the valve several times will flush the particles away. If not, the item must be disassembled, the parts thoroughly examined for signs of damage and replaced as necessary.
2. Before reinstalling the product, the air line should be purged, as stated in the "Installation" section. Air line filters should be cleaned and checked for proper operation. Properly sized mufflers should be installed in valve exhaust ports.
3. If there is heavy atmosphere contamination, valves with dustproof option "D" should be installed.



Precautions, Engineering and Maintenance Troubleshooting

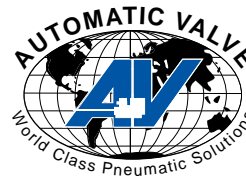

Solutions for (continued):

6. Solenoid Pilot Leakage

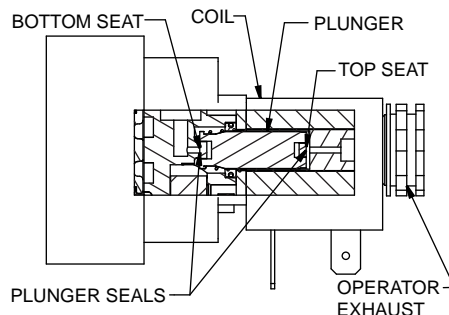

Continuous leakage from the operator exhaust port when the solenoid is de-energized can be caused by a foreign particle trapped between the bottom seat and the plunger, by a damaged bottom seat, or by a worn or damaged bottom plunger seal.

Leakage at the exhaust port and/or solenoid buzzing when the solenoid is energized can result from a foreign particle lodged in the top seat area. Leakage in this area can also be caused by worn or damaged top seats or top plunger seals.

1. The solenoid should be disassembled, cleaned, and the parts examined for wear or damage.
2. If damaged plunger seals are found, the plunger should be replaced.
3. A damaged bottom seat requires replacement of the operator.
4. A damaged top seat requires replacement of the solenoid.
5. Before reinstalling the product, also follow the recommendations regarding contaminants under Troubleshooting "#5. Solid Contaminants".

7. Operator Vent Leaks

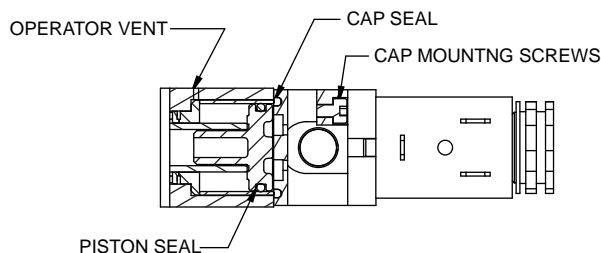

Vent leakage when the solenoid is energized can be caused by either a faulty operator piston or cap seal, by an improperly placed cap seal, or by improperly tightened cap mounting screws.

Vent leakage when the solenoid is de-energized is often caused by an improperly placed cap seal or by improperly tightened cap mounting screws.

1. In either case, tighten the cap mounting screws before disassembling the operator to determine if this will stop the problem.
2. If tightening the screws does not work, disassemble the operator, clean it, replace worn or damaged seals, and reassemble taking care to properly position the cap seal.

Solutions for (continued):

8. Mufflers

Mufflers that are undersized for the application or that have become clogged can cause slow system response or, in the case of poppet valves, system malfunction or valve oscillation.

1. Remove the muffler and cycle the valve several times to see if it operates satisfactorily without the muffler.
2. If it does, the muffler should be cleaned or, if it is not dirty, replaced with a larger muffler with adequate exhaust flow capacity.

9. Improper Lubrication

Air line lubricators that are not set at the proper flow rate or that contain lubricants not compatible with seals can cause sluggish system performance or malfunction.

1. If oil mist can be seen in the exhaust air, if films of oil are in evidence on surfaces around exhaust ports, or if pools of oil are found in valves or other devices, the lubricator is set at too high a flow rate. As a general rule, a flow rate of one drop per minute is adequate to provide a thin film of oil on moving surfaces.
2. If the flow rate is too low or the reservoir is empty, system elements that require lubrication can slow down or even bind. Lubricator reservoirs should be filled on a scheduled basis and the proper lubricator flow rate maintained.
3. Compatibility of the lubricating oil with system seals should also be verified, as stated in the Installation section. Incompatible lubricants can cause seals to swell which can result in sluggish performance or even binding of moving parts.

10. Incorrect Solenoid Voltage

Automatic Valve solenoids are designed to operate at between 90% to 110% of the rated voltage shown on the solenoid coil. A supply voltage that does not fall within the range shown can cause solenoid buzzing, failure of the valve to shift, or coil burnout.

1. To verify proper voltage, shut off and exhaust the air supply to the valve.
2. Attach a voltmeter to the solenoid's electrical supply, energize the solenoid, and note the voltage reading. If the reading is too low, the electrical supply is inadequate and must be corrected.



Precautions, Engineering and Maintenance Troubleshooting



Solutions for (continued):

11. Faulty or Dirty Solenoid

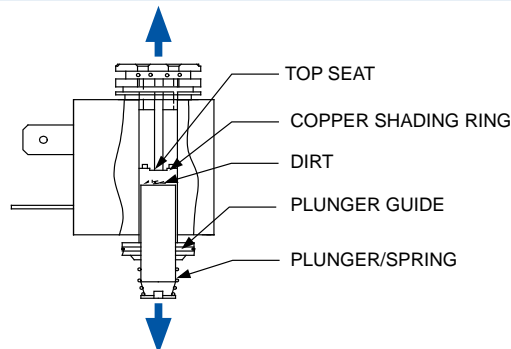

Improper voltage, broken or damaged shading rings, or dirt on the plunger or around the top seat can cause solenoid buzzing or even coil burnout.

1. The electrical supply should be shut off and the pilot section disassembled for inspection. Verify correct voltage (See Troubleshooting #10. Incorrect Solenoid Voltage).
2. If the copper shading ring around the top seat is cracked or damaged, the solenoid assembly should be replaced.
3. If dirt is found in the plunger guide and on the plunger/spring, they should be thoroughly cleaned and inspected for damage. If no damage is found the solenoid assembly can be reassembled. If damage is present, the solenoid assembly should be replaced.

12. Manual Override Left Activated

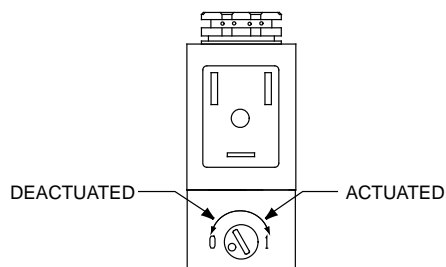

For W and X Solenoids

If a turn-locking manual override is left in the activated position, the valve will operate when the override is again cycled, from on to off and back to on, but will fail to operate electrically. This happens because the override is holding the plunger in its activated position.

1. Verify that locking type overrides are in their normal deactivated position and that non-locking overrides have not become stuck.

Shown: Direct Acting Solenoid (K02 Series)

13. Defective Coil or Wiring

Coils used by Automatic Valve seldom burn out when operated within listed voltage limits.

1. Verify that the operating voltage is correct. Refer to Troubleshooting #10. Incorrect Solenoid Voltage.
2. Verify that there is no dirt in the plunger. Refer to Troubleshooting #13. Faulty or Dirty Solenoid
3. Verify that washdown applications have not caused thermal shock.
4. Verify the integrity of the coil by shutting electrical power off and using an ohmmeter to check continuity. If the coil is open, it is burned out and must be replaced. If there is coil continuity, the electrical system should be checked for loose or broken connections and for worn or defective switches and contacts.
5. If cam operated switches are part of the electrical system, check for worn or loose cams.

Solutions for (continued):

14. Broken Spring

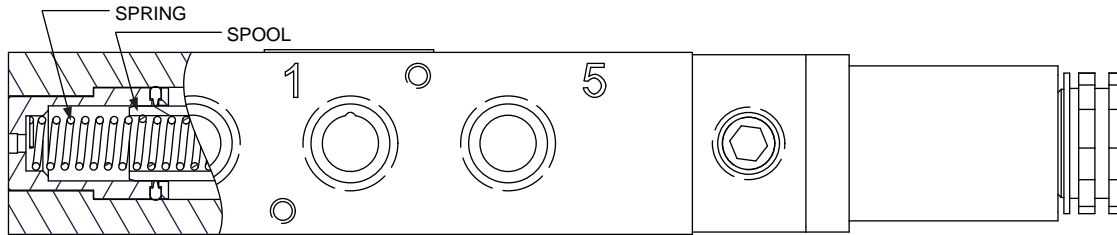

Broken springs on spring return valves can cause a valve to remain in the actuated position or to only partially return and perhaps leak to exhaust.

1. Broken springs must be replaced and are included in service kits.

15. Mechanical Binding

Mechanical binding of cylinders or other mechanical components can cause symptoms that can be improperly diagnosed as sluggish valve operation or even failure of a valve to shift. If a valve appears stuck, note the flow from the valve exhaust ports as the valve is actuated and deactivated. If there is a puff of air from each exhaust port, yet the device fails to move, the probable cause is mechanical binding.

1. Turn air and electrical power off.
2. Follow all safety precautions recommended by the manufacturer of the equipment.
3. Make mechanical inspections and adjustments as required.

16. Cam or Roller Adjustment

When cam activated valves fail to activate, check cams and rollers for proper alignment or wear.

1. Make any required adjustments.
2. Replace worn cams and rollers.

17. Maintenance

1. When disassembling, carefully place parts in same order of removal, reverse order of the drawing bill of material.
2. Refer to the Installation and Maintenance section.
3. Reassemble parts in reverse order of disassembly, in order of the drawing bill of material.



Precautions, Engineering and Maintenance Glossary

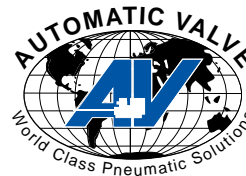

Ambient Temperature	The temperature of the immediate environment.
ATEX	European Community directive concerning equipment and protective systems intended for use in potentially explosive atmospheres.
CE	Conformite Europeenne - Certification of a product to indicate that the product satisfies all the regulations governing safety laid down by the European Community. Products displaying this mark can be freely distributed within the markets of the European Community. Consult the factory for information on products certified by CE.
Celsius, Degree	A unit of temperature measurement abbreviated °C. Celsius temps are calculated from Fahrenheit temps by the following formula: $C = \frac{5(F - 32)}{9}$
CSA	Canadian Standards Association - Provides certification services for manufacturers who, under license from CSA, wish to use the appropriate CSA marks on certain products of their manufacturer to indicate conformity with CSA standards. Consult the Factory for information on products conforming to CSA standards.
C_v	Measure of calculating flow of a valve (or other pneumatic device) that takes into effect the temperature, pressure, pressure drop, and flow.
Detent	A device for retaining movable parts in one or more fixed positions; usually a spring-loaded device fitting into a depression. Positions of parts are changed by exerting sufficient force to overcome the detent spring, or by releasing the detent.
DIN 43650/DIN 43650C	International standard for 3-pin connectors.
Fahrenheit, Degree	A unit of temperature measurement abbreviated °F. Fahrenheit temps are calculated from Celsius temps by the following formula: $F = \frac{9C}{5} + 32$
Fluid	A liquid or a gas.
FM	Factory Mutual Insurance Company partnership recognized as a Nationally Recognized Testing Laboratory (NRTL) under 29 CFR 1910.7
kPa	Kilopascals - International measure of pressure. 145 psig = 1000 kPa.
Media	The fluids used in a fluid power system. In a pneumatic system they are gases such as air, nitrogen or various inert gases.
Media Temperature	The temperature of the fluid within a valve or other device
NEMA 4	National standard for enclosure protection. Provides protection against dirt, dust, water hosedown and rain.
NEMA 7	National standard for enclosure protection.
Pressure Range	The range of inlet pressures with which a device can operate satisfactorily.
psi	Pressure - pounds per square inch - A measure of force per unit area.
psia	Absolute Pressure - pounds per square inch absolute - The sum of atmospheric pressure and gauge pressure.
psig	Gauge Pressure - pounds per square inch gauge - Pressure above or below atmospheric pressure.
PTB	Physikalisch Technische Bundesanstalt - The National Institute of Natural and Engineering Sciences and the highest technical authority for metrology and physical safety engineering of the Federal Republic of Germany.
scfm	Flow Rate - standard cubic feet per minute - The volume or weight of fluid passing through a conductor per unit of time.
Signal	A fluid or electric command to the valve actuator causing valve to change position.
Standard Air	Air at a temperature of 68°F, a pressure of 14.69 pounds per square inch absolute (psia), and a relative humidity of 36 percent (0.0750 pounds per cubic foot). In gas industries the temperature of standard air is usually specified as 60°F.
Vacuum	Pressure less than atmospheric pressure.



AUTOMATIC VALVE
41144 Vincenti Court Novi, MI USA 48375-1922
I. www.automaticvalve.com T. 248.474.6700
E. avc@automaticvalve.com F. 248.474.6732
World Class Pneumatic Solutions

Warranty

Automatic Valve warrants its products to be free from defect in material or workmanship over a period of 18 months from the date of shipment from its factory. Automatic Valve will, at its option, either repair or replace the non-conforming product at no charge upon return of the product with transportation prepaid.

Automatic Valve will replace standard commercial grade NEMA 4 solenoid coils which fail due to burnout when operated within their rated capacity or voltage.

Automatic Valve is not responsible for damage to its products through improper installation, maintenance, use, repairs or operating beyond rated capacity of voltage, intentional or otherwise. Automatic Valve is not liable for claims for labor, loss of profit or good will, repairs, delay damages, direct or indirect penalties, or expenses incidental to replacement. The buyer, by acceptance of delivery, assumes all liability for the product's use or misuse in the as-shipped condition.

Automatic Valve, recognizing its goal of continuous improvement, reserves the right to discontinue or change specifications, products or prices without incurring obligation.

Precautions

Applications: Automatic Valve manufactures general purpose, industrial pneumatic and vacuum service valves, which are not inherently harmful. However, the control systems in which they operate must have safeguards to prevent injury or damage in case of system component failure.

OSHA 1910.217, dated November 1, 1975, ANSI B11.1, Revision 1982, and EN 13736: 1999 specifically recommend special purpose dual (double) safety clutch and brake valves for power presses. Automatic Valve does not manufacture special purpose dual safety valves for presses. Do not use Automatic Valve Corp's valves for power presses.

Two position valves, whether they are 2 way, 3 way, or 4 way, will always have a flow path from the valve's inlet port or ports to one of the outlets, regardless of which of the two positions is used. If air trapped in or exhausted from the ports presents a hazard in operation or in servicing the system, a separate method must be provided to exhaust this air or the valve should not be used.

Three position 3 way and 4 way valves, whether solenoid operated, air piloted or manually operated, can move to the center position if the operators are not actuated. If air trapped in or exhausted from the ports presents a hazard in operation or in servicing the system, a separate method must be provided to exhaust this air or the valve should not be used.

Some solenoid and air piloted valves incorporate manual overrides. Manual overrides, when activated, shift the valve as if the solenoid or air pilot were actuated. If accidental or intentional operation of the manual override could cause a dangerous problem, valves without a manual override should be used.

Use valves only within specification limits listed in our catalog.

Installation: Consult the Engineering and Maintenance section of the Automatic Valve catalog #0001-001 for installation instructions. Do not install valves without first turning off air and electricity. Valves must be installed by qualified and knowledgeable personnel who understand how specific valves are to be piped and electrically connected. Do not install valves unless the valves' flow path, as described by ANSI and ISO symbols in our catalog, conform to the application's design specifications.

Maintenance: Disconnect air and electricity and bleed all pressurized lines before removing two and three position valves. Consult the Engineering and Maintenance section of the Automatic Valve catalog #0001-001 for maintenance instructions. Servicing should only be undertaken by qualified and knowledgeable personnel who understand the function and operation of specific valves. Care must be followed to prevent damage to valves caused by stepping on them, dropping them or hitting them with any object. Damaged valves should be returned to Automatic Valve for inspection and rebuilding.

