



***Series LA***  
***Air/Water Cylinders***

- High-Tech Duralon® Rod Bearing
- 150 PSI Air or Water Pressure Ratings
- 3.25" – 26.00" Bore Sizes
- MX3 and ME3 Mounting Styles
- AWWA Construction Available
- Optional Bronze or Stainless Steel Construction Available

# SERIES LA AIR/WATER CYLINDERS

**HANNA**  
cylinders

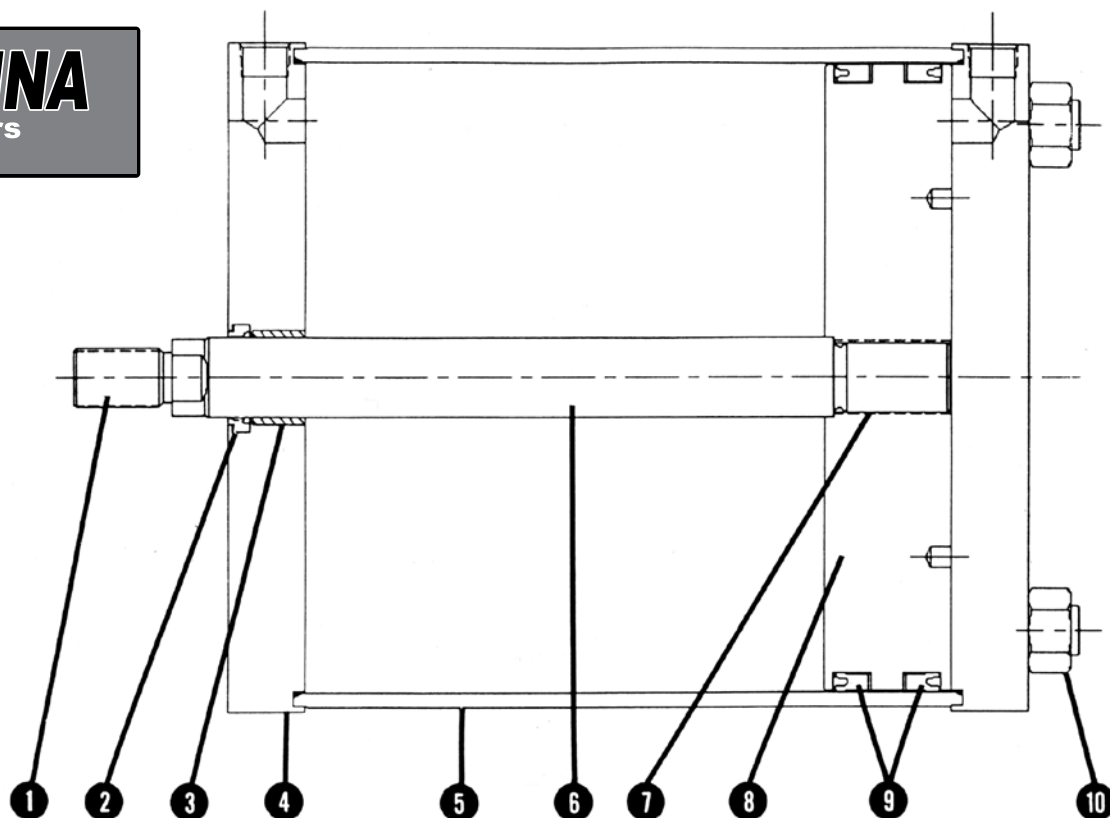

## Series LA Features and Benefits

### 1. Piston Rod End

Integral thread construction, precision machined for close concentricity.

### 2. Rod Seal and Wiper

Self-regulating, pressure-energized Buna N material prevents contaminants from entering cylinder.

### 3. Duralon Rod Bearing

Non-metallic bearing is impervious to corrosion, has an extremely low coefficient of friction and requires no lubrication to the bearing surface. Capable of sustaining much higher compressive loads than either bronze or cast iron.

### 4. Heads

Steel heads are precision machined to assure accurate alignment and close concentricity between piston, tube, piston rod and rod bearing.

### 5. Tubing

Steel tubing is precision-honed to 16 rms, and chrome-plated for corrosion resistance.

### 6. Piston Rod

Hanna's piston rods are machined to a close tolerance with minimum stock removal to maximize shank size and reduce stress. Relief grooves are machined in areas of high stress to guard against fatigue failures. All sizes are hard chrome-plated for scratch and corrosion resistance, and polished to a 6-8 micro-inch finish.

### 7. Piston-to-Rod Connection

Piston rods are piloted to the piston to ensure concentricity, then bonded by an anaerobic adhesive, torqued and pinned.

### 8. Piston

One piece ductile iron piston is threaded to piston rod, and furnished with breakaway spirals on each side.

### 9. Piston Sealing System

Two Buna U-cups seals are self-regulating and pressure-energized for excellent sealing capabilities.

### 10. Tie-Rods and Tie-Rod Nuts

Tie-rods and tie-rod nuts are made of high strength, corrosion-protected steel.

# SERIES LA 3.25" – 26.00" Bores

## MX3 Tie Rod Mount

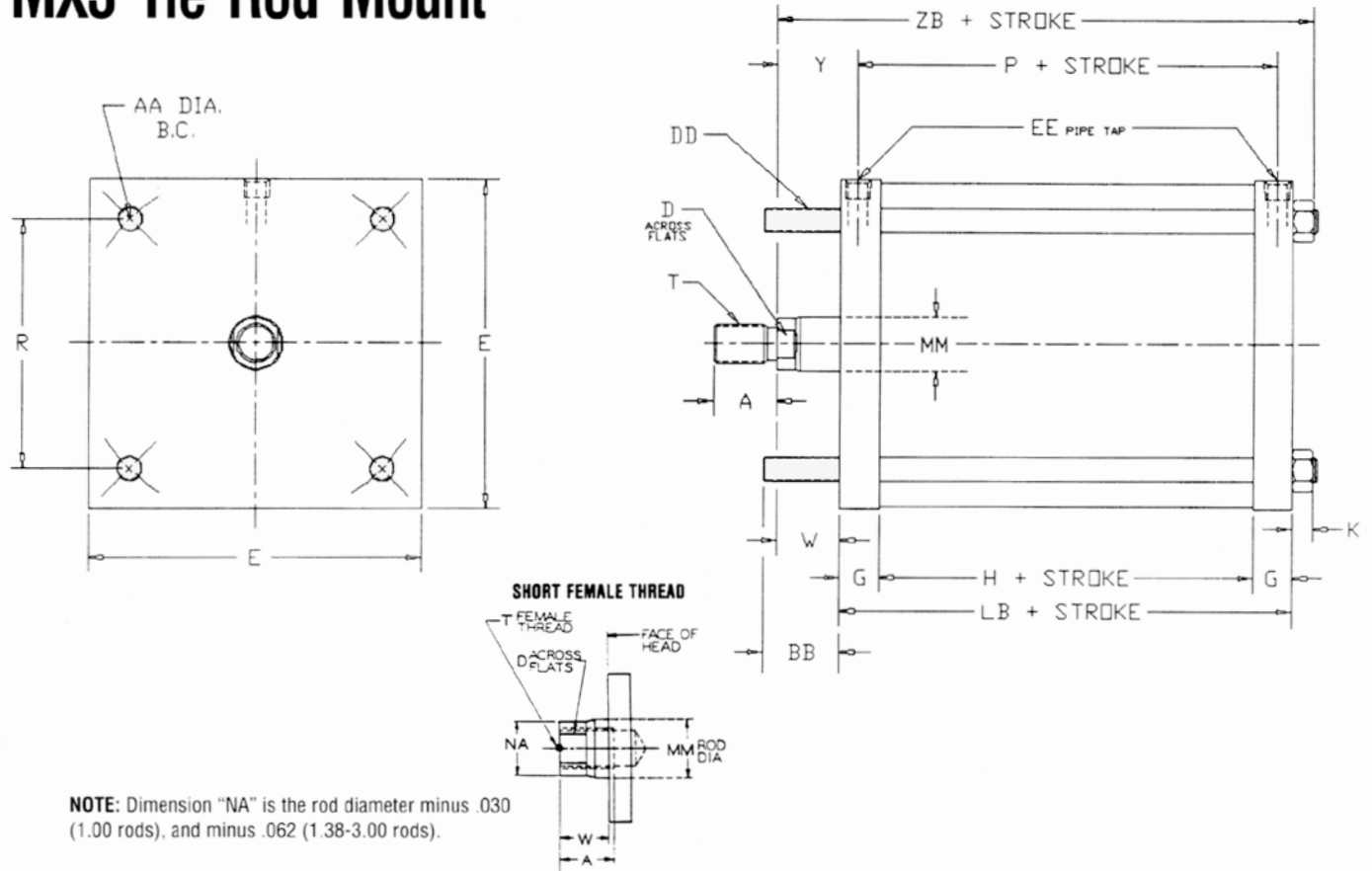

CYLINDER			A	AA	BB	D	DD	E	EE NPTF	G	H	K	LB	P	R	T (THREAD)		W	Y	ZB
BORE	ROD DIA. CODE	MM ROD DIA.														SMALL MALE SM	SHORT FEMALE SF			
3.25	F	1.00	1.12	3.90	1.38	0.88	.38-24	4.00	1/4	0.88	1.25	0.38	3.00	2.31	2.76	.75-16	.75-16	0.75	0.34	4.12
4.00	F	1.00	1.12	4.70	1.38	0.88	.38-24	4.50	3/8	1.00	1.25	0.38	3.25	2.44	3.32	.75-16	.75-16	0.75	0.41	4.38
5.00	F	1.00	1.12	5.80	1.81	0.88	.50-20	5.50	3/8	1.00	1.50	0.44	3.50	2.69	4.10	.75-16	.75-16	0.75	0.41	4.69
6.00	F	1.00	1.12	6.90	1.81	0.88	.50-20	6.50	3/8	1.00	1.50	0.44	3.50	2.69	4.88	.75-16	.75-16	0.88	0.41	4.81
7.00	F	1.00	1.12	8.10	2.00	0.88	.62-18	7.50	3/8	1.00	1.62	0.56	3.62	2.81	5.73	.75-16	.75-16	0.88	0.41	5.06
8.00	F	1.00	1.12	9.10	2.00	0.88	.62-18	8.62	3/8	1.00	1.62	0.56	3.62	2.81	6.44	.75-16	.75-16	0.88	0.41	5.06
10.00	F	1.00	1.12	11.20	2.25	0.88	.75-16	10.75	1/2	1.25	2.12	0.66	4.62	3.53	7.92	.75-16	.75-16	1.00	0.55	6.28
12.00	G	1.38	1.62	13.30	2.25	1.12	.75-16	12.75	1/2	1.25	2.62	0.66	5.12	4.03	9.40	1.00-14	1.00-14	1.00	0.55	6.78
14.00	G	1.38	1.62	15.40	2.50	1.12	.88-14	14.75	3/4	1.50	3.12	0.75	6.12	4.81	10.90	1.00-14	1.00-14	1.00	0.66	7.87
16.00	H	1.75	2.00	17.80	2.75	1.50	1.00-14	17.00	3/4	2.00	2.50	0.94	6.50	5.00	12.59	1.25-12	1.25-12	1.25	0.75	8.69
18.00	J	2.00	2.25	20.00	3.25	1.69	1.12-12	19.00	3/4	2.00	2.50	1.12	6.50	5.00	14.14	1.50-12	1.50-12	1.50	0.75	9.12
20.00	J	2.00	2.25	22.30	3.25	1.69	1.25-12	21.00	3/4	2.00	2.50	1.19	6.50	5.00	15.77	1.50-12	1.50-12	1.50	0.75	9.19
22.00	K	2.50	3.00	24.50	3.25	2.06	1.25-12	23.25	1	2.50	2.75	1.19	7.75	5.75	17.32	1.88-12	1.88-12	1.50	1.00	10.44
24.00	K	2.50	3.00	26.50	3.25	2.06	1.25-12	25.25	1	2.50	2.75	1.19	7.75	5.75	18.74	1.88-12	1.88-12	1.50	1.00	10.44
26.00	L	3.00	3.00	28.50	3.25	2.62	1.25-12	27.25	1	2.50	2.75	1.19	7.75	5.75	20.15	2.25-12	2.25-12	1.50	1.00	10.44

Note: 16.00" bore & larger will have tie rod washers.

# SERIES LA 8.00" – 26.00" Bores

## ME3 Head Square Mount

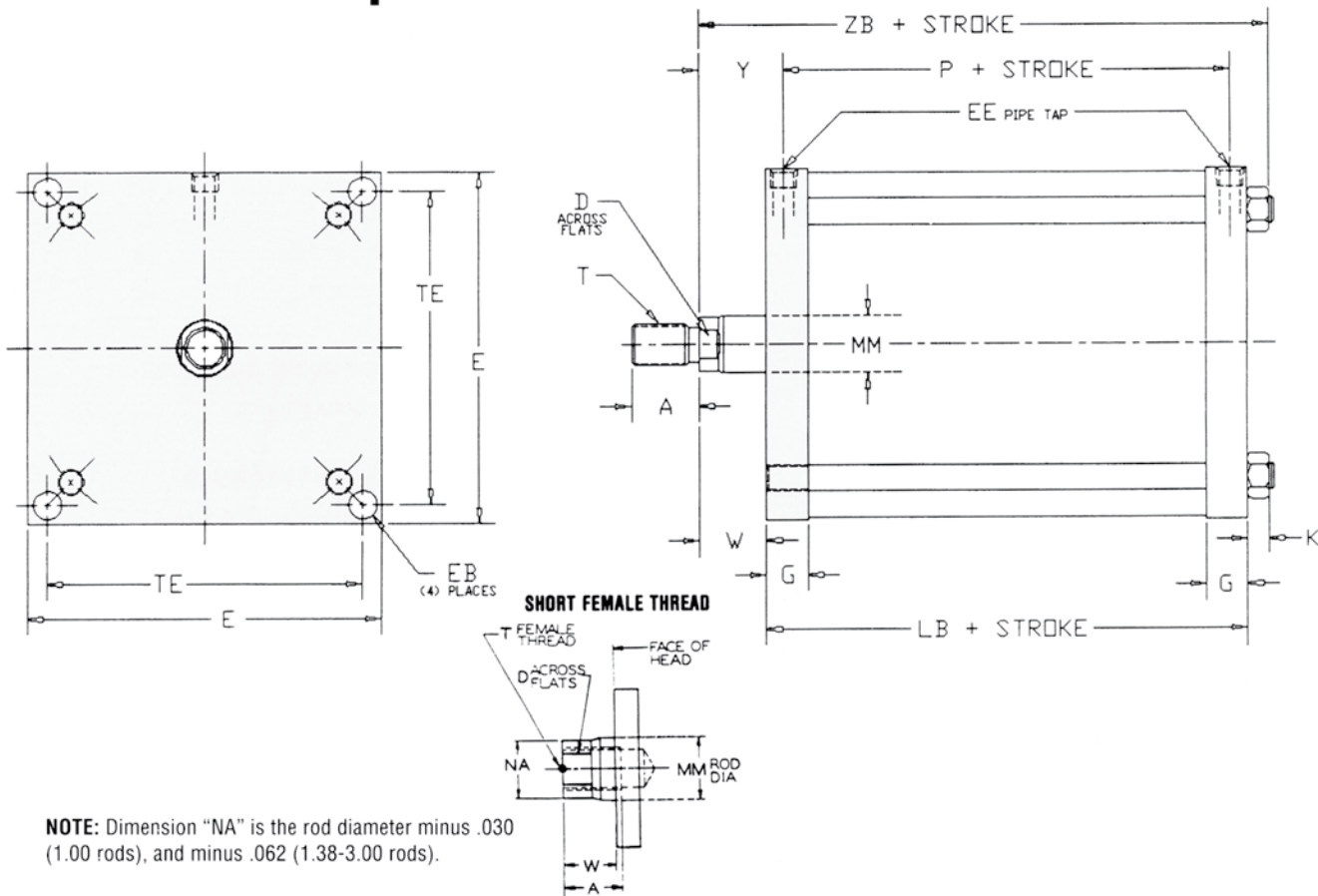

**NOTE:** Dimension "NA" is the rod diameter minus .030 (1.00 rods), and minus .062 (1.38-3.00 rods).

CYLINDER			T (THREAD)														
BORE	ROD DIA. CODE	MM ROD DIA.	A	D	E	EB*	EE NPTF	G	K	LB	P	SMALL MALE SM	SHORT FEMALE SF	TE	W	Y	ZB
8.00	F	1.00	1.12	0.88	8.62	0.62	3/8	1.00	0.56	3.62	2.81	.75-16	.75-16	7.57	0.88	0.41	5.06
10.00	F	1.00	1.12	0.88	10.75	0.75	1/2	1.25	0.66	4.62	3.53	.75-16	.75-16	9.40	1.00	0.55	6.28
12.00	G	1.38	1.62	1.12	12.75	0.75	1/2	1.25	0.66	5.12	4.03	1.00-14	1.00-14	11.10	1.00	0.55	6.78
14.00	G	1.38	1.62	1.12	14.75	0.88	3/4	1.50	0.75	6.12	4.81	1.00-14	1.00-14	12.87	1.00	0.66	7.87
16.00	H	1.75	2.00	1.50	17.00	1.00	3/4	2.00	0.94	6.50	5.00	1.25-12	1.25-12	14.85	1.25	0.75	8.69
18.00	J	2.00	2.25	1.69	19.00	1.12	3/4	2.00	1.12	6.50	5.00	1.50-12	1.50-12	16.53	1.50	0.75	9.12
20.00	J	2.00	2.25	1.69	21.00	1.25	3/4	2.00	1.19	6.50	5.00	1.50-12	1.50-12	18.46	1.50	0.75	9.19
22.00	K	2.50	3.00	2.06	23.25	1.25	1	2.50	1.19	7.75	5.75	1.88-12	1.88-12	20.75	1.50	1.00	10.44
24.00	K	2.50	3.00	2.06	25.25	1.25	1	2.50	1.19	7.75	5.75	1.88-12	1.88-12	22.75	1.50	1.00	10.44
26.00	L	3.00	3.00	2.62	27.25	1.25	1	2.50	1.19	7.75	5.75	2.25-12	2.25-12	24.75	1.50	1.00	10.44

\*Mounting holes are .06 larger than bolt size.

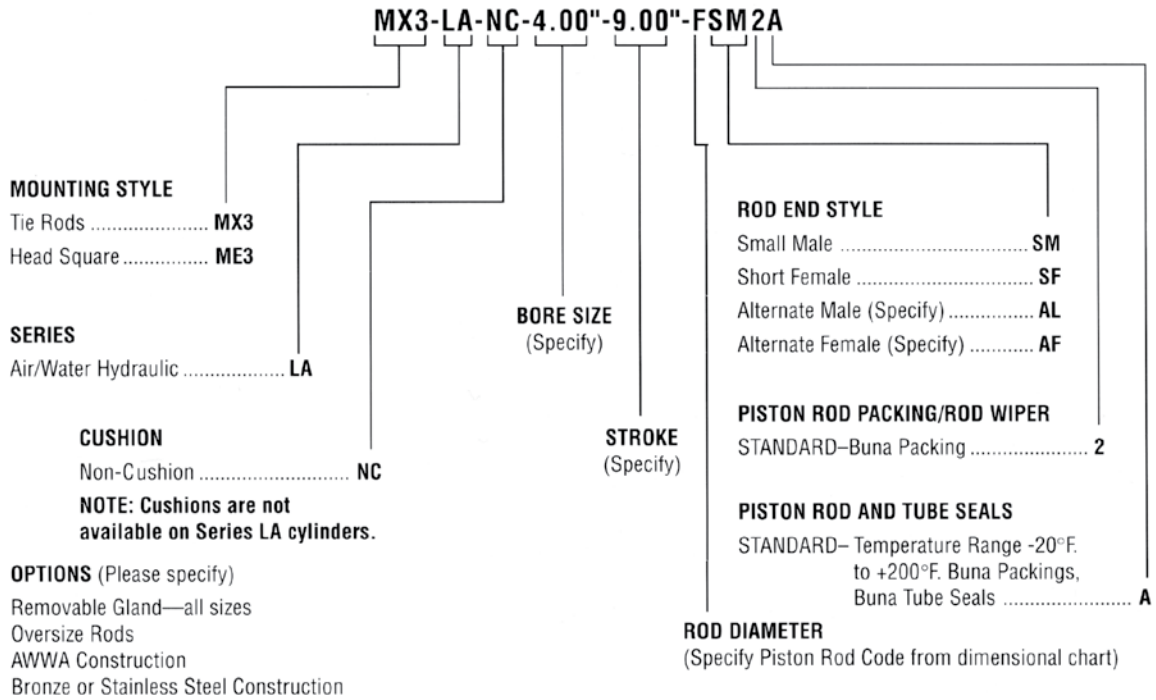

## PARTS LIST

When ordering replacement parts, identify Model Number, Serial Number and Part Number, as shown below.

PART NO.	QTY.	DESCRIPTION
1	4	Tie Rod
2	4	Tie Rod Nut
3	1	Back Head
4	2	U-Cup Packing
5	1	Piston
6	1	Tube
7	2	O-Ring
8	1	Front Head
9	1	Duralon Rod Bearing
10	1	Rod Wiper-Seal
11	1	Piston Rod

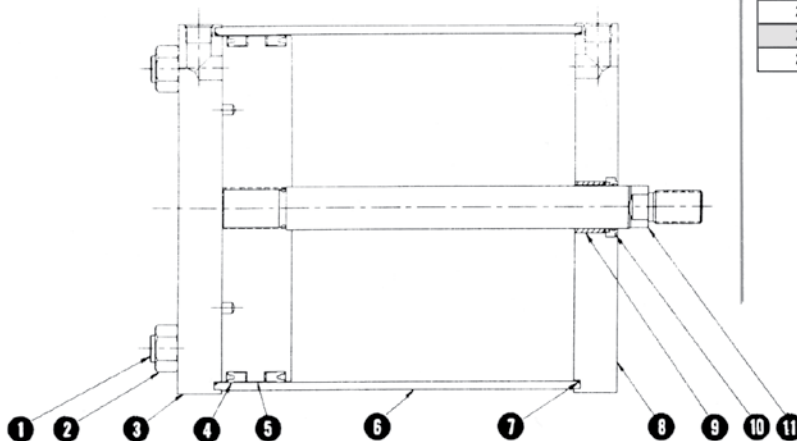

## TIE-ROD TORQUES

BORE	SIZE	TORQUE IN FT.-LBS.	
		MX3	ME3
3.25	.38-24	30	—
4.00	.38-24	30	—
5.00	.50-20	50	—
6.00	.50-20	50	—
7.00	.62-18	75	—
8.00	.62-18	75	50
10.00	.75-16	95	65
12.00	.75-16	95	65
14.00	.88-14	150	100
16.00	1.00-14	240	160
18.00	1.12-12	330	220
20.00	1.25-12	500	350
22.00	1.25-12	500	350
24.00	1.25-12	500	350
26.00	1.25-12	500	350