

Series MH

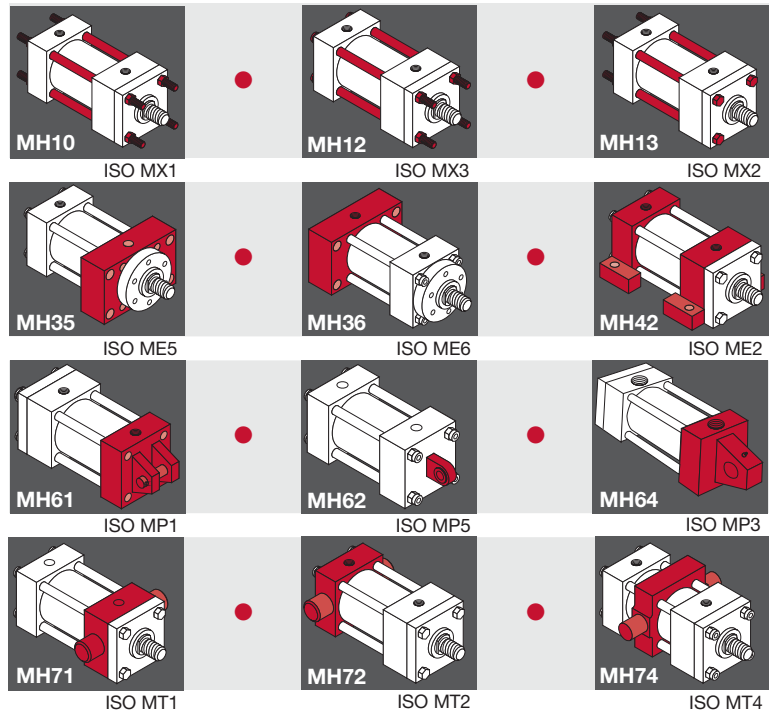

Milwaukee Cylinder Series MH ISO Metric Hydraulic Cylinders are built to perform on the toughest applications. Series MH is a complete line of ISO standard hydraulic tie rod cylinders, with maximum operating pressures up to 210 bar on all standard bore sizes. If your application requires higher operating pressures, consult our engineers. *Milwaukee Cylinder* helps you solve even more application needs with our expanded ISO Metric Cylinder product line.

		<i>METRIC Cylinder Piston Rod End</i>	<i>Inside Cover page iii</i>
	General	<i>Standard Specifications and Features</i>	38
		<i>Performance Tested Design Features</i>	39
		<i>Tie Rod Mount</i>	40-41
	Mounting Specifications	<i>Solid End Cap and Side Lug Mount</i>	42-43
		<i>Pin Mount</i>	44-45
		<i>Trunnion Mount</i>	46-47
		<i>Double Rod End Cylinders</i>	48
		Additional Information	<i>Ordering Information</i>

STANDARD SPECIFICATIONS

- Standard construction – square head – tie-rod design
- Nominal pressure – 210 bar; see info box below
- Standard fluid-hydraulic oil
- Standard temperature – -20° C to +150° C
- Standard bore sizes – 25 mm thru 200 mm
- Standard piston rod diameters 12 mm thru 140 mm
- Standard mounting styles– 12 standard styles and custom designs to suit your needs
- Strokes – available in any practical stroke length
- Cushions – available at either end or both ends of stroke
- Three standard rod end styles and specials designed to order

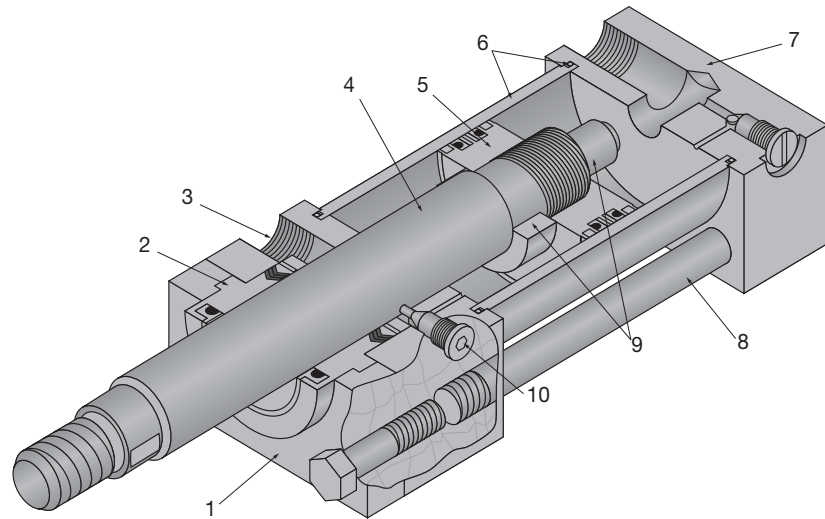

STANDARD FEATURES

1. Removable Retainer Plate

The retainer plate and rod bushing are externally removable without disassembling the cylinder on most standard models. Four capscrews securely hold and lock the retainer plate in place.

2. Rod Bushing and Seals

A U-cup Rod Seal with a supporting bronze bushing is standard in *Milwaukee Cylinder Series MH* Cylinders.

3. Ports

BSP/G cylinder ports are standard and can be located to customer requirements. ISO.6149 ports optional.

4. Piston Rod

The piston rod is of high strength steel, hardened and plated to resist scoring and corrosion, assuring maximum life.

5. Piston

The piston is of fine grained alloy iron, incorporating u-cup seals, ensuring non-leak Hi-Lo pressure performance. The piston is pilot fitted and threaded to the rod.

6. Cylinder Barrel and Seals

The barrel is of steel tubing, honed to a fine finish to assure superior sealing, minimum friction and maximum seal life.

7. End Caps

End caps and mountings are of high quality steel, precision machined for accurate mounting.

8. Tie-Rods and Nuts

The tie-rods are constructed from a high quality medium carbon steel. On most sizes the threads are rolled for rigid engagement of the self-locking nuts.

9. Cushions

Cushions are machined to close tolerance to provide positive, smooth deceleration at the end of stroke. On all bore sizes, we provide the longest cushion possible based on the rod size and blind end caps. Longer cushions are available; for further information, consult factory.

10. Cushion Needle Adjustment and Ball Check

The cushion needle adjustment valve and cushion-check ball retainer screw are specifically designed to provide full cushion adjustment.



If your hydraulic operating pressure exceeds 210 bar, send your application data for engineering evaluation and design recommendations.



MilCad Cylinder Configurator

Visit milwaukeeecylinder.com to configure and download CAD files of your cylinders.

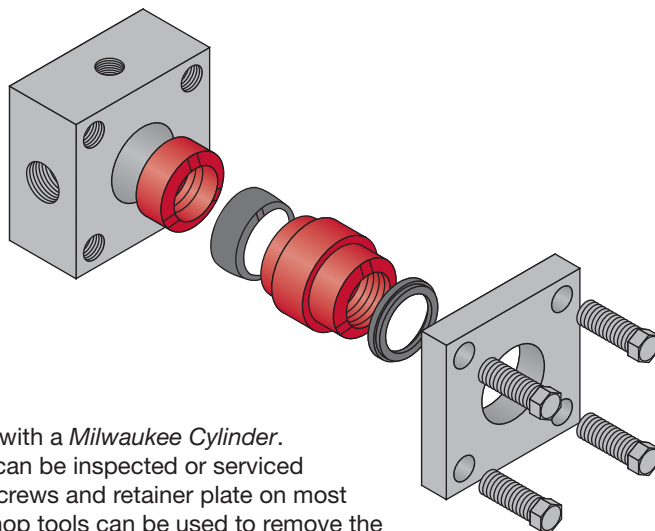

Simple Maintenance...

Simple maintenance is reality with a *Milwaukee Cylinder*. The rod bushing or rod seals can be inspected or serviced by merely removing the cap screws and retainer plate on most models. Standard available shop tools can be used to remove the rod bushing and seals without disturbing the torque on the tie-rods, assuring performance quality with maintenance ease.

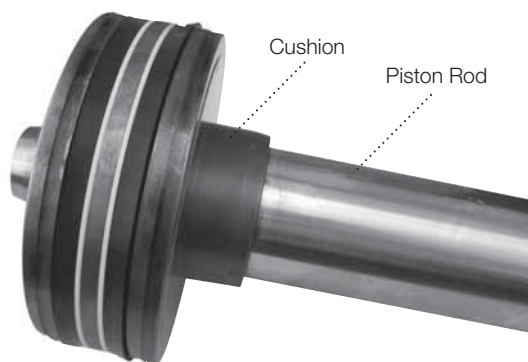

Cushions...

The cushion is of a high-grade alloy, precision machined and specially tapered to provide smooth deceleration of the piston at the end of stroke.

A standard manufacturing process at *Milwaukee Cylinder* is to assemble the piston, cushion, and the piston rod; placing the assembly between centers and checking the critical diameters for concentricity.

Piston Rod...

The piston rod is hardened, plated high strength steel, machined and processed to resist scoring and corrosion, assuring maximum life. *Milwaukee Cylinder* offers three rod end styles as standard. **The style #2 rod end with two wrench flats is furnished as standard** unless otherwise specified. Special rod ends and extra wrench flats are also available. They must be specified at the time of order, giving the dimensional requirements and the location of additional wrench flats.

COMBINATION ROD SEAL DESIGN...

The Series MH cylinder design is a one-piece rod bushing with a double lip u-cup rod seal, a supporting bearing ring, and a double lip wiper.

COMBINATION SEALING ROD

The Series MH cylinder combines two bi-directional sealing u-cup seals and a fine grained alloy iron piston. This proven piston seal design is effective at both high and low pressures. The design gives the wear and shock absorbing qualities of cast iron and the near zero leakage of the u-cup seals.

25 & 32mm Bore Cylinders

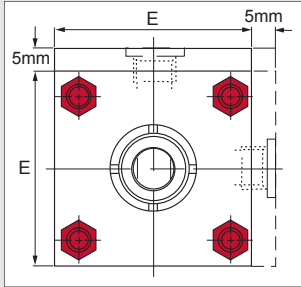

5mm extra height applies to port face at the rod end caps only.

TIE ROD MOUNTED CYLINDERS

The flange and tie-rod mounts are basically the same, except that the cylinder tie-rods are extended and used to mount the cylinder. To prevent misalignment, sagging, or possible binding of the cylinder, when long strokes are required, the free end should be supported. The best use of tie-rods when extending on the blind end is in a thrust load application. When using tie-rods extended on the rod end, the best application is a tension load. Tie rod mounts are suited for many applications, but it should be noted that they are not as rigid as the flange type of mounting.

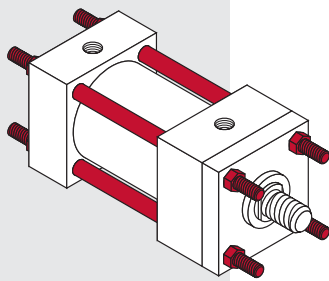

MODEL MH10
ISO STYLE MX1

TIE RODS EXTENDED BOTH ENDS

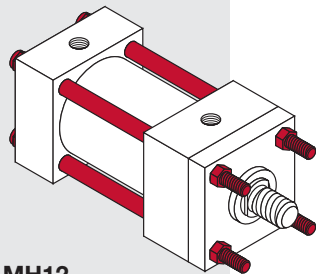
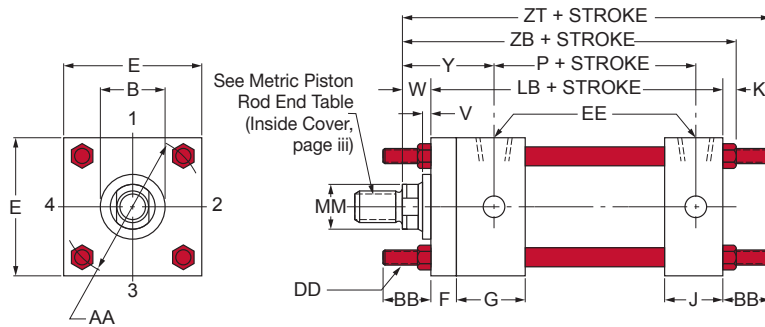

MODEL MH12
ISO STYLE MX3

TIE RODS EXTENDED ROD END

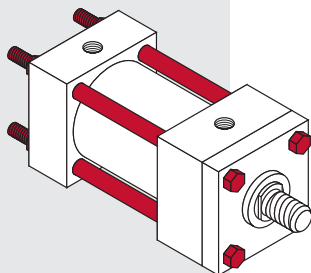
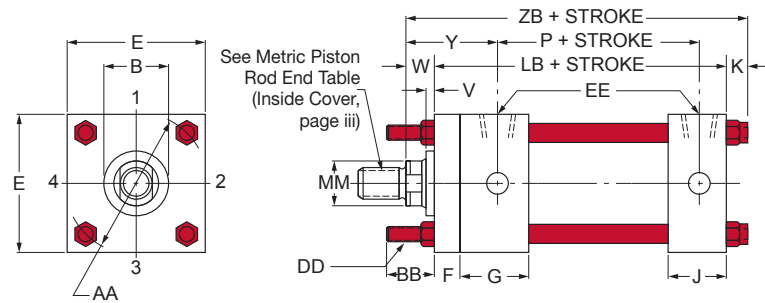

MODEL MH13
ISO STYLE MX2

TIE RODS EXTENDED BLIND END

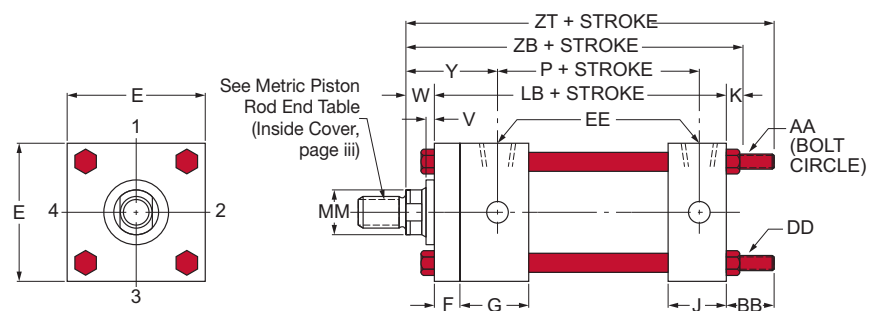

▼ TABLE 1MH The dimensions given on this table are affected by the piston rod diameter and the stroke.

Bore Ø	Rod MM	Cylinder Code ♦	B	LB	P	V	W	Y	ZB	ZT	
25	12	MH0151	24	99	53	6	15	50	121	133	
	18△	MH0152	30								
32	14	MH1510	26	103	56	12	25	60	137	152	
	22†	MH1511	34								
40	18	MH1520	30	128	73	6	25	62	163	188	
	28†	MH1521	42								
50	22	MH1530	34	134	74	6	25	67	174	205	
	28	MH1531	42			9					
	36†	MH1532	50			6					
63	28	MH1540	42	136	80	6	32	71	183	214	
	36	MH1541	50			9					
	45	MH1542	60			13					
80	36	MH1550	50	159	93	5	31	77	209	249	
	45	MH1551	60			9					
	56	MH1552	72			7					
100	45	MH1560	60	168	101	7	35	82	222	262	
	56	MH1561	72			10					
	70	MH1562	88			10					
125	56	MH1570	72	197	117	10	35	86	258	313	
	70	MH1571	88								7
	90	MH1572	108								7
160	70	MH1580	88	213	130	7	32	86	273	337	
	90	MH1581	108								7
	110	MH1582	133								7
200	90	MH1590	108	267	165	7	32	98	330	414	
	110	MH1591	133								7
	140	MH1592	163								7

△ Cushions not available on rod end.

† Available with fixed nonadjustable cushions on rod end and standard adjustable cushions on the blind end only.

▼ TABLE 2MH The dimensions are constant regardless of rod diameter or stroke.

Bore Ø	AA	BB	DD	E	EE BSPP	F	G	J	K
25	40	19	M5 X 0.8	40	¼	10	40	25	7
32	47	24	M6 X 1	45	¼	10	40	25	9
40	59	35	M8 X 1	63	⅜	10	45	38	10
50	74	46	M12 X 1.25	75	½	16	45	38	15
63	91	46	M12 X 1.25	90	½	16	45	38	15
80	117	59	M16 X 1.5	115	¾	20	50	45	19
100	137	59	M16 X 1.5	130	¾	22	50	45	19
125	178	81	M22 X 1.5	165	1	22	58	58	26
160	219	92	M27 X 2	205	1	25	58	58	28
200	269	115	M30 X 2	245	1¼	25	76	76	31

HOW TO ORDER

For ordering information refer to page 49.

CAUTION NOTES:

NOTES:

- ♦ For double rod end cylinders, add prefix letter D to cylinder code. Example: DMH0151. (Refer to page 48.)



Rod End Styles and Dimensions

For rod end styles and dimensions see the table in the inside cover of the brochure "METRIC Piston Rod End Styles".

Page iii



MilCad Cylinder Configurator

Visit milwaukeekeeylinder.com to configure and download CAD files of your cylinders.

25 & 32mm Bore Cylinders*

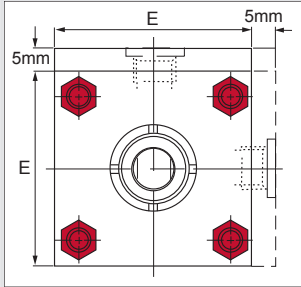

5mm extra height applies to port face at the rod end caps only.

Flange rated for 210 bar operation.

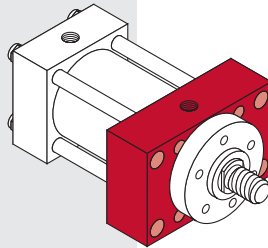

MODEL MH35* ISO STYLE ME5

* On 25 mm and 32 mm bore, MH35 mount cylinders with port in position 2 or 4, head height is increased by 5 mm in position 1.

SOLID END CAP MOUNTED CYLINDERS

Milwaukee Cylinder's solid end cap mount is one of the strongest, most rigid methods of mounting. This type of rod end cap mounting is best in a tension application. A solid blind end cap mounting is best in a thrust application.

SOLID ROD END CAP MOUNT

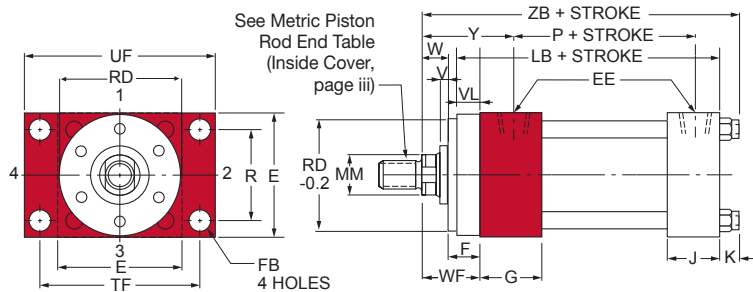

SOLID BLIND END CAP MOUNT

Flange rated for 210 bar operation.

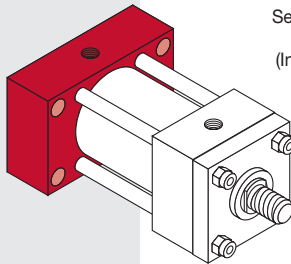

MODEL MH36 ISO STYLE ME6

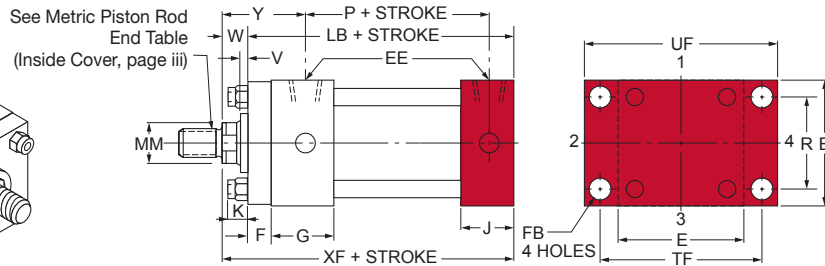

SIDE OR LUG MOUNTED CYLINDERS

The side or lug mounted cylinder provides a fairly rigid mount. These types of cylinders can tolerate a slight amount of misalignment when the cylinder is at full stroke, but as the piston moves toward the blind end, the tolerance for misalignment decreases. It is important to note that if the cylinder is used properly (without misalignment), the mounting bolts are either in simple shear or tension without any compound stresses.

25 mm and 35 mm port at Rod End available in Position #1 only.

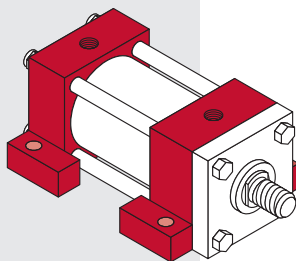

MODEL MH42 ISO STYLE MS2

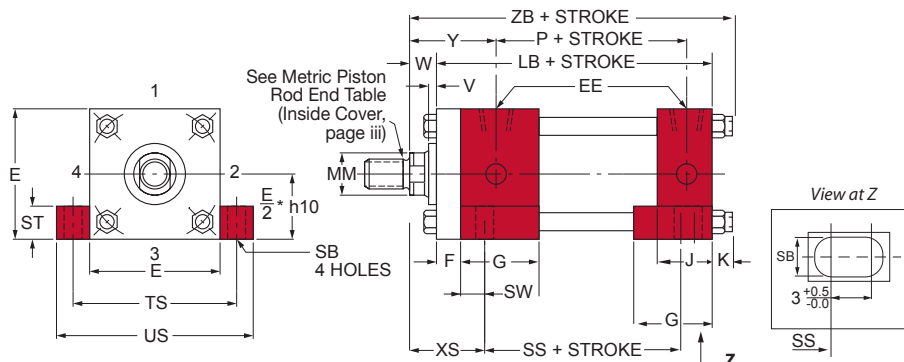

▼ TABLE 1MH The dimensions given on this table are affected by the piston rod diameter and the stroke.

Bore Ø	Rod MM	Cylinder Code ♦	B	LB	P	RD f8	SS	V	VL min.	W	WF	XF	XS	Y	ZB
25	12	MH0151	24	99	53	38	72	6	3	15	25	114	33	50	121
	18△	MH0152	30												
32	14	MH1510	26	103	56	42	72	12	3	25	35	128	45	60	137
	22†	MH1511	34												
40	18	MH1520	30	128	73	62	97	6	3	25	35	153	45	62	163
	28†	MH1521	42					12							
50	22	MH1530	34	134	74	74	91	6	4	25	41	159	54	67	174
	28	MH1531	42					9							
63	28	MH1540	42	136	80	75	85	6	4	32	48	168	65	71	183
	36	MH1541	50			82		9							
80	45	MH1551	60	159	93	82	104	5	4	31	51	190	68	77	209
	56	MH1552	72			88		9							
100	56	MH1560	60	168	101	92	101	7	5	35	57	203	79	82	222
	70	MH1562	88			105		10							
125	70	MH1570	72	197	117	105	130	7	5	35	57	232	79	86	258
	90	MH1572	108			150		10							
160	90	MH1580	88	213	130	125	129	7	5	32	57	245	86	86	273
	110	MH1582	133			170									
200	110	MH1590	108	267	165	150	171	7	5	32	57	299	92	98	330
	140	MH1592	163			210									

△ Cushions not available on rod end.

† Available with fixed nonadjustable cushions on rod end and standard adjustable cushions on the blind end only.

▼ TABLE 2MH The dimensions are constant regardless of rod diameter or stroke.

Bore Ø	E	EE BSPP	F	FB	G	J	K	R	SB	ST	SW	TS	TF	UF	US
25	40*	¼	10	5.5	40	25	7	27	6.6	8.5	8	54	51	65	72
32	45*	¼	10	6.5	40	25	9	33	9	12.5	10	63	58	70	84
40	63	⅜	10	11	45	38	10	41	11	12.5	10	83	87	110	103
50	75	½	16	14	45	38	15	52	14	19	13	102	105	130	127
63	90	½	16	14	45	38	15	65	18	26	17	124	117	145	161
80	115	¾	20	18	50	45	19	83	18	26	17	149	149	180	186
100	130	¾	22	18	50	45	19	97	26	32	22	172	162	200	216
125	165	1	22	22	58	58	26	126	26	32	22	210	208	250	254
160	205	1	25	26	58	58	28	155	33	38	29	260	253	300	318
200	245	1¼	25	33	76	76	31	190	39	44	35	311	300	360	381

* 25 mm and 35 mm port at Rond End available in position #1 only.

HOW TO ORDER

For ordering information refer to page 49.

NOTES:

- ♦ For double rod end cylinders, add prefix letter D to cylinder code. Example: DMH0151. (Refer to page 48.) Double rod ends are not available on clevis mount Series MH cylinders



Rod End Styles and Dimensions

For rod end styles and dimensions see the table in the inside cover of the brochure "METRIC Piston Rod End Styles".

Page iii



MilCad Cylinder Configurator

Visit milwaukeekeeylinder.com to configure and download CAD files of your cylinders.

25 & 32mm Bore Cylinders

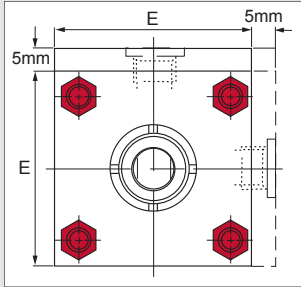

5mm extra height applies to port face at the rod end caps only.

PIN MOUNTED CYLINDERS

All pin cylinders need a provision on both ends for pivoting. These types of cylinders are designed to carry shear loads and pivot pins should be carried by bearings that are rigidly held and closely fit for the entire length of the pin.

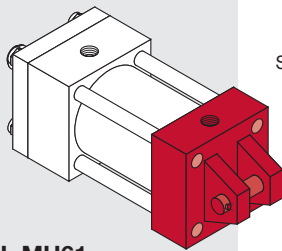

**MODEL MH61
ISO STYLE MP1**

CLEVIS MOUNT

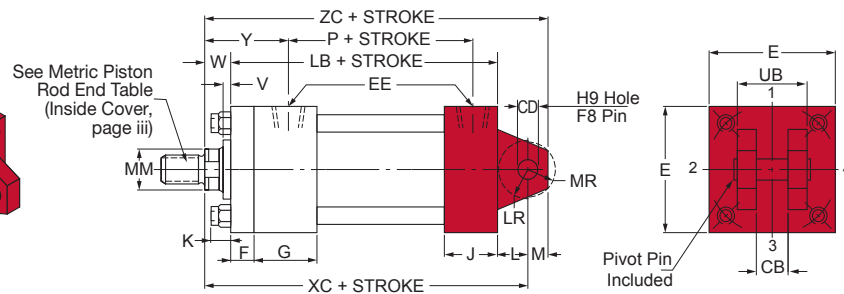

CLEVIS MOUNT

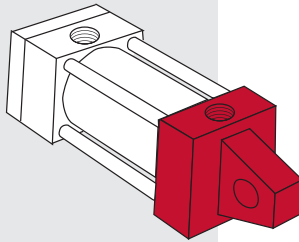

**MODEL MH64
ISO STYLE MP3**

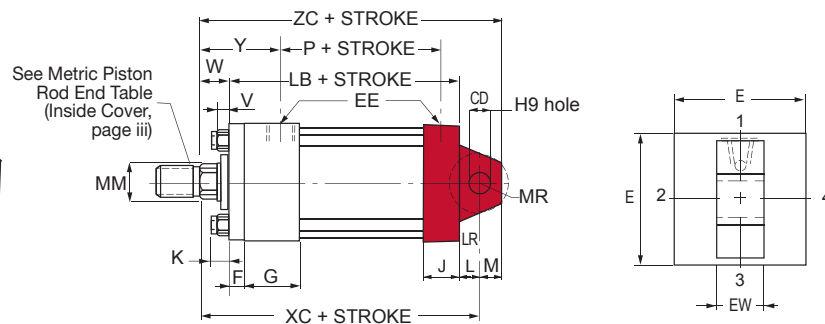

FIXED EYE MOUNT

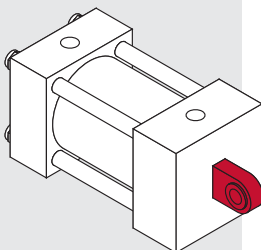

**MODEL MH62
ISO STYLE MP5**

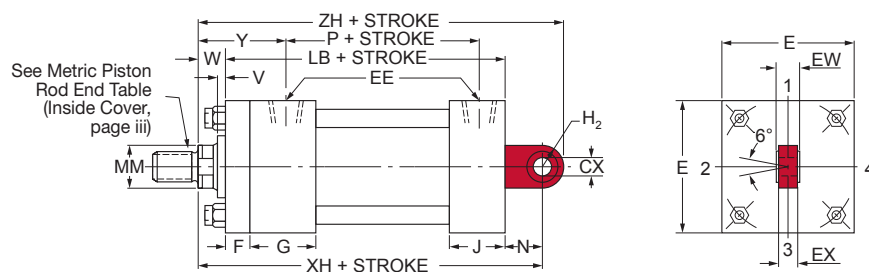

▼ TABLE 1MH The dimensions given on this table are affected by the piston rod diameter and the stroke.

Bore Ø	Rod MM	Cylinder Code ♦	B	LB	P	V	W	XC	XH	Y	ZC	ZH
25	12	MH0151	24	99	53	6	15	127	130	50	137	150
	18△	MH0152	30									
32	14	MH1510	26	103	56	12	25	147	148	60	159	170.5
	22†	MH1511	34									
40	18	MH1520	30	128	73	6	25	172	178	62	186	207
	28†	MH1521	42			12						
50	22	MH1530	34	134	74	6	25	191	190	67	211	223
	28	MH1531	42			9						
63	28	MH1540	42	136	80	6	32	200	206	71	220	246
	36	MH1541	50			9						
	45	MH1542	60			13						
80	36	MH1550	50	159	93	5	31	229	238	77	257	288
	45	MH1551	60			9						
	56	MH1552	72			9						
100	45	MH1560	60	168	101	7	35	257	261	82	295	323
	56	MH1561	72			10						
	70	MH1562	88			7						
125	56	MH1570	72	197	117	7	35	289	304	86	334	384
	70	MH1571	88			10						
	90	MH1572	108			10						
160	70	MH1580	88	213	130	7	32	308	337	86	367	437
	90	MH1581	108			7						
	110	MH1582	133			7						
200	90	MH1590	108	267	165	7	32	381	415	98	451	535
	110	MH1591	133			7						
	140	MH1592	163			7						

△ Cushions not available on rod end.

† Available with fixed nonadjustable cushions on rod end and standard adjustable cushions on the blind end only.

HOW TO ORDER

For ordering information refer to page 49.

NOTES:

♦ For double rod end cylinders, add prefix letter D to cylinder code. Example: DMH0151. (Refer to page 48.) Double rod ends are not available on clevis mount Series MH cylinders.



Rod End Styles and Dimensions
For rod end styles and dimensions see the table in the inside cover of the brochure "METRIC Piston Rod End Styles".

Page iii



MilCad Cylinder Configurator

Visit milwaukeekeecylinder.com to configure and download CAD files of your cylinders.

▼ TABLE 2MH The dimensions are constant regardless of rod diameter or stroke.

Bore Ø	CB A16	CD	CX	E	EE BSPP	EP	EW h14	EX	F	G	H2 max.	J	K	L	LR	M	MR	N	UB max.
25	12	10	12 -0.008	40	¼	8	12	10	10	40	20	25	7	13	12	10	12	16	24
32	16	12	16 -0.008	45	¼	11	16	14	10	40	22.5	25	9	19	17	12	15	20	32
40	20	14	20 -0.012	63	⅜	13	20	16	10	45	29	38	10	19	17	14	16	25	40
50	30	20	25 -0.012	75	½	17	30	20	16	45	33	38	15	32	29	20	25	31	60
63	30	20	30 -0.012	90	½	19	30	22	16	45	40	38	15	32	29	20	25	38	60
80	40	28	40 -0.012	115	¾	23	40	28	20	50	50	45	19	39	34	28	34	48	80
100	50	36	50 -0.012	130	¾	30	50	35	22	50	62	45	19	54	50	36	44	58	100
125	60	45	60 -0.015	165	1	38	60	44	22	58	80	58	26	57	53	45	53	72	120
160	70	56	80 -0.015	205	1	47	70	55	25	58	100	58	28	63	59	59	59	92	140
200	80	70	100 -0.020	245	1¼	57	80	70	25	76	120	76	31	82	78	70	76	116	160

Series MH
Series LH
Series A
Series MN
Hyd-Pne Devices
Cyl Accessories
Manipulators
Power Units/Valves
Design Guide

For Package and Mounting Dimension see Tables 1MH and 2MH.

25 & 32mm Bore Cylinders

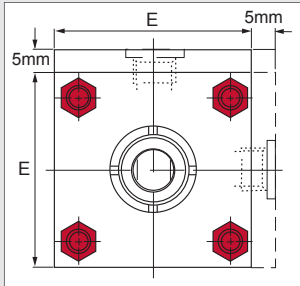

5mm extra height applies to port face at the rod end caps only.

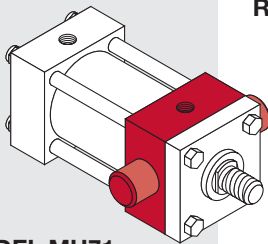

MODEL MH71
ISO STYLE MT1

TRUNNION MOUNTED CYLINDERS

All trunnion cylinders need a provision on both ends for pivoting. These types of cylinders are designed to carry shear loads and the trunnion and pivot pins should be carried by bearings that are rigidly held and closely fit for the entire length of the pin.

i See "CAUTION NOTE on page 47.

ROD END TRUNNION MOUNT

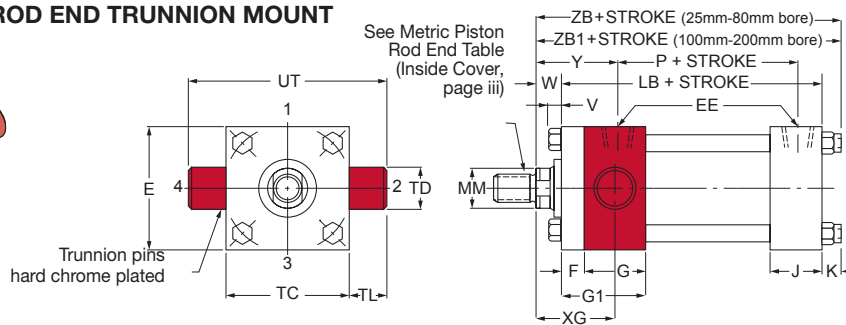

i **MH71** mount cylinders with bore sized 100mm through 200mm DO NOT have bolts on the rod end. Tie rods are threaded into the rod end cap. Use **ZB1** and **G1** for this bore size range.

BLIND END TRUNNION MOUNT

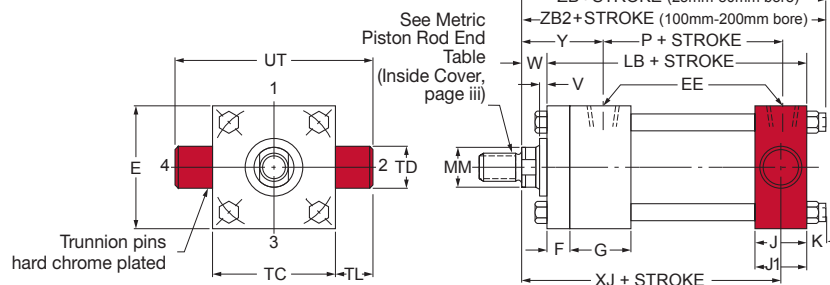

i **MH72** mount cylinders with bore sized 100mm through 200mm DO NOT have nuts on the blind end. Tie rods are threaded into the blind end cap, and secured with nuts (K) on the rod end. Use **ZB2** and **J1** for this bore size range.

CENTER TRUNNION MOUNT

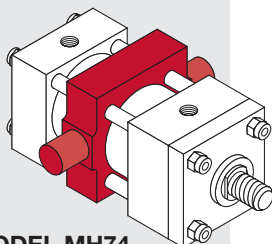
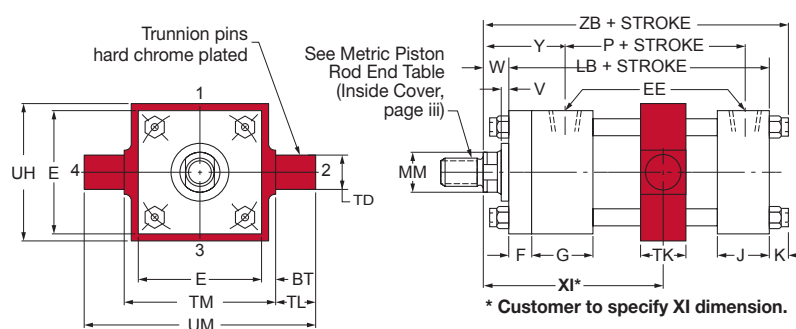

MODEL MH74
ISO STYLE MT4

TABLE 1MH The dimensions given on this table are affected by the piston rod diameter and the stroke.

Bore Ø	Rod MM	Cylinder Code ♦	B	LB	P	V	W	XG	XJ	Y	ZB	ZB1	ZB2
25	12	MH0151	24	99	53	6	15	44	101	50	121	-	-
	18△	MH0152	30										
32	14	MH1510	26	103	56	12	25	54	115	60	137	-	-
	22†	MH1511	34										
40	18	MH1520	30	128	73	6	25	57	134	62	163	-	-
	28†	MH1521	42			12							
50	22	MH1530	34	134	74	6	25	64	140	67	174	-	-
	28	MH1531	42			9							
63	28	MH1540	42	136	80	6	32	70	149	71	183	-	-
	36	MH1541	50			9							
80	45	MH1551	60	159	93	9	31	76	168	77	209	-	-
	56	MH1552	72			5							
100	45	MH1560	60	168	101	7	35	71	187	82	222	222*	216**
	56	MH1561	72			10							
125	56	MH1570	72	197	117	7	35	75	209	86	258	258*	246**
	70	MH1571	88			10							
160	70	MH1580	88	213	130	7	32	75	230	86	273	278*	275**
	90	MH1581	108			7							
200	110	MH1591	133	267	165	7	32	85	276	98	330	337*	331**
	140	MH1592	163			7							

△ Cushions not available on rod end.

† Available with fixed nonadjustable cushions on rod end and standard adjustable cushions on the blind end only.

* Use this dimension for MH71 mount cylinders with bore sizes 100mm through 200mm.

** Use this dimension for MH72 mount cylinders with bore sizes 100mm through 200mm.

HOW TO ORDER

For ordering information refer to Page 49.

CAUTION NOTES:

* Rod end trunnion mount cylinders in 160mm bore (all rod sizes) and 200mm bore, (110 and 140 sizes) should not be used over 100 bar. If your application requires higher pressure, consult the factory.

NOTES:

♦ For double rod end cylinders, add prefix letter D to cylinder code. Example: DMH0151. (Refer to page 48.) Double rod ends are not available on clevis mount Series MH cylinders.



Rod End Styles and Dimensions
For rod end styles and dimensions see the table in the inside cover of the brochure "METRIC Piston Rod End Styles".

Page iii



MilCad Cylinder Configurator

Visit milwaukeeecylinder.com to configure and download CAD files of your cylinders.

TABLE 2MH The dimensions are constant regardless of rod diameter or stroke.

Bore Ø	BT	E	EE BSPP	F	G	G1	J	J1	K	TD f8	TC h14	TL	TM h14	TK	UH	UM	UT
25	9	40	¼	10	40	-	25	-	7	12	38	10	48	20	45	68	58
32	11	45	¼	10	40	-	25	-	9	16	44	12	55	25	54	79	68
40	14.5	63	⅜	10	45	-	38	-	10	20	63	16	76	30	76	108	95
50	17	75	½	16	45	-	38	-	15	25	76	20	89	40	89	129	116
63	17.5	90	½	16	45	-	38	-	15	32	89	25	100	40	95	150	139
80	22	115	¾	20	50	-	45	-	19	40	114	32	127	50	127	191	178
100	25	130	¾	22	50	72	45	58	19	50	127	40	140	60	140	220	207
125	31.5	165	1	22	58	80	58	72	26	63	165	50	178	73	178	278	265
160	36.5	205	1	25	58	88	58	88	28	80	203	63	215	90	216	341	329
200	57	245	1¼	25	76	108	76	108	31	100	241	80	279	110	280	439	401

* Use this dimension for MH71 mount cylinders with bore sizes 100mm through 200mm.

** Use this dimension for MH72 mount cylinders with bore sizes 100mm through 200mm.

25 & 32mm Bore Cylinders

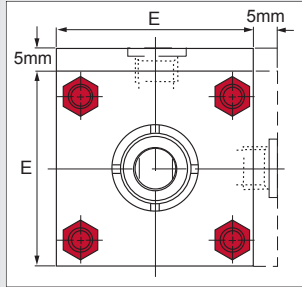

5mm extra height applies to port face at the rod end caps only.

DOUBLE ROD END CYLINDERS

Double rod end styles are available in every mounting style except clevis. On double rod end cylinders where the rod ends are not the same, be sure to specify clearly which rod end is to go at which end of the cylinder in relation to your mounting requirements.

To obtain dimensional information on a double rod end cylinder, first select the desired mounting style and refer to the corresponding single rod end cylinder model shown on the preceding pages. After you have determined all necessary dimensions from the previous page covering the desired mounting, turn back to this page. Supplement those dimensions with additional ones from the drawing below and the table at the right. These added dimensions differ from, or are in addition to, those shown on the preceding pages and provide the additional information needed to completely dimension a double rod end cylinder model.

On a double rod end cylinder where two different rod ends are required, or two different rod sizes are required, or cushions on one end are required, be sure to state clearly which rod is to go at which end of the cylinder. When two types of mounting styles are required, be sure to specify their relationship to the piston rods, if they are not the same.

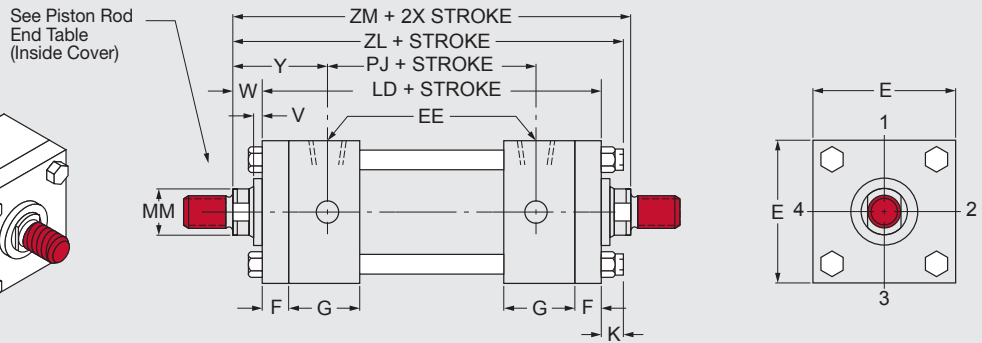
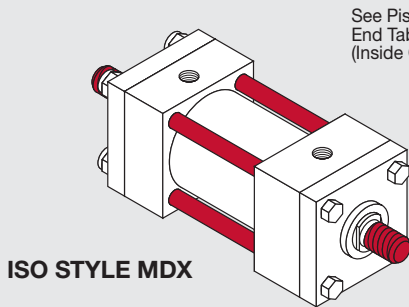

TABLE 2MH

The dimensions are constant regardless of rod diameter or stroke.

Bore Ø	E	F	G	K	EE BSPP
25	40	10	40	7	¼
32	45	10	40	9	¼
40	63	10	45	10	⅜
50	75	16	45	15	½
63	90	16	45	15	½
80	115	20	50	19	¾
100	130	22	50	19	¾
125	165	22	58	26	1
160	205	25	58	28	1
200	245	25	76	31	1¼

DOUBLE ROD END CYLINDERS

Bore Ø	Rod MM	Cylinder Code	B	LD	PJ	V	W	Y	ZL	ZM
25	12	DMH0151	24	124	54	6	15	50	146	154
	18	DMH0152	30							
32	14	DMH1510	26	128	58	12	25	60	162	178
	22	DMH1511	34							
40	18	DMH1520	30	145	71	6	25	62	180	195
	28	DMH1521	42			12				
50	22	DMH1530	34	157	73	6	25	67	197	207
	28	DMH1531	42			6				
	36	DMH1532	50			9				
63	28	DMH1540	42	159	81	6	32	71	206	223
	36	DMH1541	50			9				
	45	DMH1542	60			13				
	36	DMH1550	50			5				
80	45	DMH1551	60	184	92	9	31	77	234	246
	56	DMH1552	72			9				
	45	DMH1560	60			7				
100	56	DMH1561	72	195	101	7	35	82	249	265
	70	DMH1562	88			10				
	56	DMH1570	72			7				
125	70	DMH1571	88	219	117	10	35	86	280	289
	90	DMH1572	108			10				
	70	DMH1580	88			7				
160	90	DMH1581	108	238	130	7	32	86	298	302
	110	DMH1582	133			7				
	90	DMH1590	108			7				
200	110	DMH1591	133	292	160	7	32	98	355	488
	140	DMH1592	163			7				

Series MH, Ordering Information

▼ CONFIGURE YOUR CYLINDER (Series MH Metric Cylinder Nomenclature)

1
 MH1552 -
 61 -
 2
 4
 4
 9 X
 425

1 Double Rod End
 2 Cylinder Code (Refer to Table 1MH)
 3 Mounting Style
 4 Rod End Style
 5 Cushions
 6 Cylinder Modifications (If standard leave blank)
 7 Seal
 8 Stroke

Note:

Use "S" if any special design features are required, describe in detail on your order.

Example:

The code for a MP1 mount metric hydraulic cylinder with an 80mm bore, 56mm rod, Style No. 2 rod end, cushion both ends, standard seals with a 425mm stroke is MH1552-61-24-9 x 425

	Feature	Description	Page No.	Code No.
1	Double Rod End		—	D
2	Cylinder Code	Refer to Table 1MH	7, 9, 11, 13	—
3	Mounting Style	Model Number Only	6, 8, 10, 12	—
4	Rod End Style	Code Number	Inside front cover (iii)	—
5	Cushions	None Rod End Blind End Both Ends	— — — —	1 2 3 4
6	Cylinder Modifications	Special	—	S
7	Seal	Polyurethane (-20° to 200° F)	—	9
8	Stroke	Specify in millimeters	—	—

Series MH

Series LH

Series A

Series MN

Hyd-Pneu Devices

Cyl Accessories

Manipulators

Power Units/Valves

Design Guide